

# The Month's New Model

## A Meccano Trench-Digging Machine

THE prototype of the model to be described this month is of special interest on account of its originality and its labour-saving capabilities. It is of course only possible to use it over comparatively soft ground, but where it is necessary to lay water, electric, or gas mains over such ground it has many advantages. It is also quick and cheap for carrying out large drainage schemes, and in this type of work the track units with which it is fitted make it possible for it to operate on ground that is too soft for other machines, or even for men. The machine, which has been designed and built by E. Ayers and Co. Ltd., has been tested in many parts of the country and under a variety of conditions with very successful results.

### Building the Meccano Model

The main frames are constructed first, and are shown in Figs. 1 and 2. Each side consists of a channel section girder built up from two  $24\frac{1}{2}$ " Angle Girders, and both sides are connected together at one end by double  $3\frac{1}{2}$ " Flat Girders

2. A  $3\frac{1}{2}$ " channel section girder

3 is also fitted, and is used later

for carrying the steering mechanism. The end carrying this girder is also fitted with doubled  $4\frac{1}{2}$ " Strips 4 carrying at their extremities  $1\frac{1}{2}$ " Angle Girders. The Bolts securing these short Angle Girders in position have Washers placed under their heads. Three  $3\frac{1}{2}$ " Strips are secured across the gap between the two Girders, forming a seat for the driver. A foot rest is also provided, and this is built up from three  $2\frac{1}{2}$ "  $\times$   $\frac{1}{2}$ " Double Angle Strips coupled together by two  $1\frac{1}{2}$ " Strips. The complete rest is suspended from the Strips 4 by four  $1\frac{1}{2}$ " Strips, one Washer being placed on each securing Bolt between the short Strips and the Strips 4.

The main frames are now complete, and the driving track is fitted. The two sides of the track framework, each of which consists of two  $4\frac{1}{2}$ " Strips, are coupled together by means of two  $1\frac{1}{2}$ "  $\times$   $\frac{1}{2}$ " Double Angle Strips. The two centre holes of the frame carry a  $3\frac{1}{2}$ " Rod on which is mounted two 1" Sprocket Wheels, the Rod being prevented from lateral movement by two Collars. The complete frame is mounted so that it is free to swing on the  $4\frac{1}{2}$ " Rod that is supported in the end holes of two Trunnions bolted to the main frames of the

model. Two further Collars prevent the track frame from moving sideways. Each end of the frame carries a 2" Rod on which is mounted two  $1\frac{1}{2}$ " Sprocket Wheels, one Rod in addition, carrying a 1" Sprocket Wheel that is connected by a short length of Sprocket Chain to one of the 1" Sprocket Wheels on the  $3\frac{1}{2}$ " Rod mentioned earlier. The four  $1\frac{1}{2}$ " Sprocket Wheels are now connected together in pairs by Sprocket Chain, the two endless belts so formed representing the driving tracks. The drive from the motor, which will be fitted later, is taken to the remaining 1" Sprocket Wheel on the  $3\frac{1}{2}$ " Rod.

The steering tracks are now fitted, and are supported in 1" Triangular Plates that are bolted to the

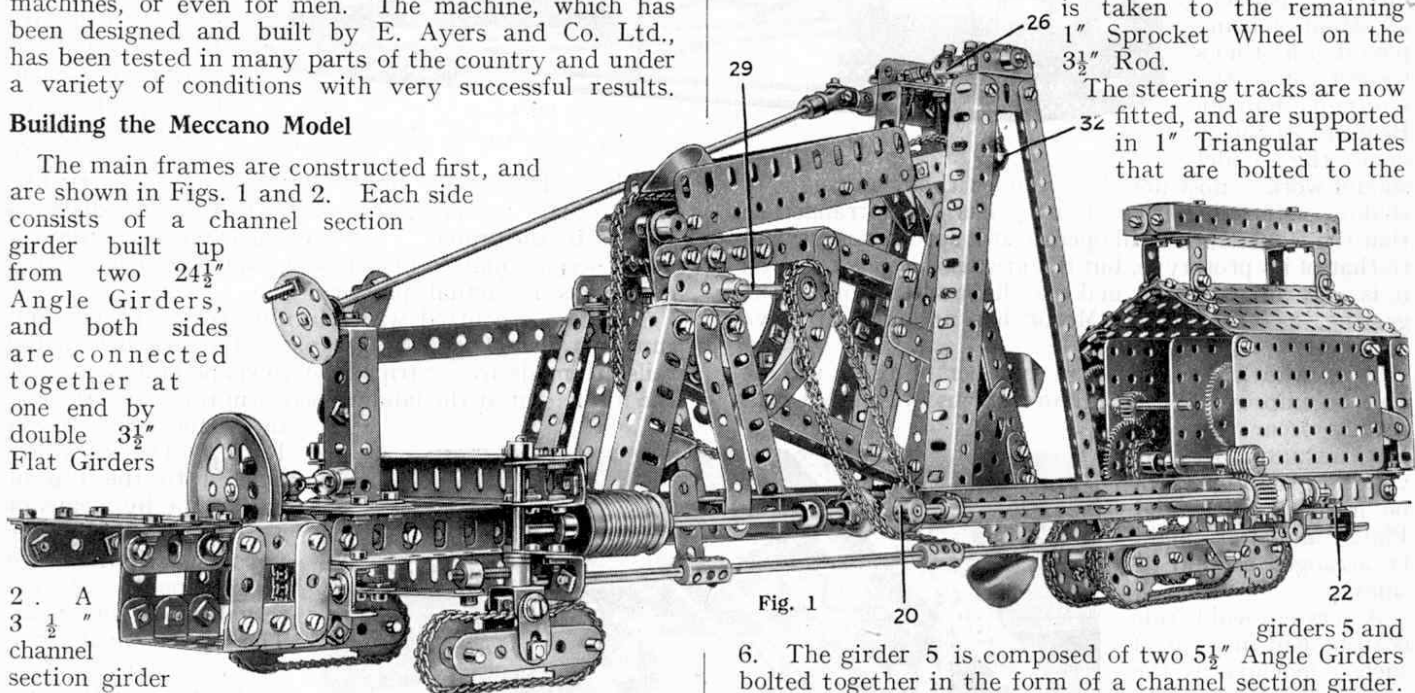

Fig. 1

girders 5 and 6. The girder 5 is composed of two  $5\frac{1}{2}$ " Angle Girders bolted together in the form of a channel section girder. Each end of 5 and 6 is fitted with three 1" Triangular Plates, and these support a 2" Rod fitted at its upper end with a Collar and at its lower end with a Large Fork Piece. Two Washers are placed between the Fork Piece and its respective Triangular Plate. The Fork Piece carries a 1" Threaded Rod 7 together with two Flat Brackets, one to each lug. A  $2\frac{1}{2}$ " Strip is attached pivotally to each Flat Bracket, and each pair carries at its extremity 1" Sprocket Wheels. The endless track consists of a length of Sprocket Chain passed round the two Sprockets.

The Threaded Rods 7 and 8 are next connected, this being done by fitting a Collar on each and securing a Strip five in. long between them. This strip is built up from two 3" Strips overlapping two holes, the two ends of the complete link being pivotally attached to the Collars. The Threaded Rod 8 carries, in addition to a Collar, a Threaded Boss by means of which a Flat Bracket is fixed to the Rod. A Hinge is locknutted to this Flat Bracket, and also bolted securely to a 2" Strip the free end of which is pivotally attached by means of a  $\frac{3}{8}$ " Bolt to a Coupling 9. This is mounted on a 2" Rod journalled in the plain bore of a Handrail Support, a

Collar being used for spacing purposes between the Coupling and Handrail Support. The opposite end of the Rod carries four Washers and a 1" Sprocket Wheel, the Washers being used for spacing purposes between the Sprocket and its supporting Girder. A short length of Sprocket Chain connects the Sprocket Wheel with a  $\frac{3}{4}$ " Sprocket Wheel on the steering column 10, which consists of a  $2\frac{1}{2}$ " Rod journalled in two Handrail Supports. The steering wheel is represented by a 2" Pulley Wheel which may be fitted with a length of Spring Cord in order to improve its appearance at the rim.

The power unit is now fitted. This consists of a Meccano No. 6 Electric Motor bolted down to the transverse Strips 1. A  $1\frac{1}{2}$ " Strip 11 is secured to one side of the reversing switch of the Motor, and this will protrude from the side of the bonnet when this is fitted later. A  $\frac{1}{2}$ " Pinion on the motor armature shaft engages with a 57-teeth Gear that is fitted, together with a second  $\frac{1}{2}$ " Pinion, on a  $2\frac{1}{2}$ " Rod. This second Pinion drives a 57-teeth Gear that in turn drives a similar Gear 12 through a third  $\frac{1}{2}$ " Pinion 13. The Gear 12 is mounted on a  $3\frac{1}{2}$ " Rod that carries a  $\frac{3}{4}$ " Sprocket Wheel and a Worm 14. The 1" Sprocket Wheel drives the front driving track by means of a short length of Sprocket Chain. The use of the Worm 14 will be described later.

The bonnet unit, Fig. 4, consists of three separate units, the bonnet proper, the radiator and the petrol tank. Each side of the top of the bonnet consists of four  $5\frac{1}{2}$ " Strips joined together by two 2" Strips, the two complete sides being coupled by two bent Flat Brackets. A  $4\frac{1}{2} \times 2\frac{1}{2}$ " Flat Plate is now secured to each side of the pointed top, as shown in the illustration, by means of Flat Brackets, which are bent to the required shape after being fitted.

The radiator frame consists of two  $2\frac{1}{2}$ " Angle Girders connected together at the bottom by a  $3\frac{1}{2}$ " Angle Girder and at the top by a  $3\frac{1}{2}$ " Strip. This frame is attached to the lower edges of the bonnet top by two Flat Brackets, and the triangular space remaining between the radiator and bonnet is filled in by two  $1\frac{1}{2}$ " Strips and a Corner Bracket, the  $1\frac{1}{2}$ " Strip being extended by Flat Brackets. The radiator tubes are represented by 2" Rods, Couplings and Collars being used to secure them in place to the lower  $3\frac{1}{2}$ " Angle Girder.

The petrol tank is built up from four  $5\frac{1}{2} \times \frac{1}{2}$ " Double Angle Strips, and the rectangular trough so formed rests on two  $5\frac{1}{2}$ " Strips bolted to the top of the radiator by means of  $1" \times 1"$  and  $\frac{1}{2} \times \frac{1}{2}"$  Angle Brackets. The Double Angle Strips are attached to the  $5\frac{1}{2}$ " Strips by means of four  $\frac{3}{4}$ " Bolts, as it is impossible to get the Nuts on to ordinary Bolts inside the finished petrol tank.

The complete radiator is secured to the frame of the model by the  $3\frac{1}{2}$ " Angle Girder of the radiator, and also by the  $\frac{1}{2} \times \frac{1}{2}"$  Angle Brackets 15, Figs. 2 and 3.

The next thing to be considered is the clutch and transmission for the dredger buckets and the endless belt for depositing the excavated earth to one side of the trench. The Worm 14 engages with a  $\frac{1}{2}$ " diameter  $\frac{1}{2}$ " face Pinion 16 that is secured in one end of a Socket Coupling, the other end of which is occupied by one half of a Dog Clutch. The remaining half of the Dog Clutch is gripped on an  $11\frac{1}{2}$ " Rod 17, on which the Pinion member 16 is free to rotate. The Rod 17, which is mounted in bearings consisting of three  $1" \times 1"$  Angle Brackets, carries the  $\frac{3}{4}"$  Contrate Wheel 18, which meshes with a  $\frac{1}{2}"$  Pinion that in turn engages with a second  $\frac{3}{4}"$  Contrate Gear mounted on the  $6\frac{1}{2}"$  Rod 19. The  $\frac{1}{2}"$  Pinion is secured together with a  $\frac{3}{4}"$  Sprocket Wheel 20, on a 2" Rod that is supported in the bosses of two Double Arm Cranks, it being free to revolve in these.

The free end of the Rod 19 is fitted with a drum, consisting of a Sleeve Piece and two  $\frac{3}{4}"$  Flanged Wheels, which is connected by 10 lengths of Spring Cord to a similar drum on the opposite side of the frame (see Figs. 1 and 3). This second drum is mounted on a 2" Rod that is free to revolve in the end holes of two  $1" \times 1"$  Angle Brackets bolted to the main frame.

The clutch member, attached to the Pinion 16, is operated by a claw composed of a Coupling and two 1" Rods, the complete part being secured rigidly to a long rod 21. This long rod, which is built up from one  $11\frac{1}{2}"$  and one 8" Rod, is journalled at one end in the bracket 22, Fig. 2, and at the other end in a  $1\frac{1}{2}"$  Strip bolted to the  $5\frac{1}{2}"$  Angle Girder 6. A Coupling, fixed on the rod 21, is attached pivotally to a Double Arm Crank that is mounted on a transverse  $4\frac{1}{2}"$  Rod. This Rod is fitted with a Crank 23, extended by means of a  $3"$  Strip that is connected by a  $4\frac{1}{2}"$  Strip and a  $2\frac{1}{2}"$  Strip, forming a handle, to the stand 24. This stand is built up from two  $2\frac{1}{2} \times 2\frac{1}{2}"$  Double Angle Strips bolted to one side of the main frames. It will now be seen that, by actuating the  $2\frac{1}{2}"$  Strip, the clutch, fitted to the Pinion 16, is engaged or disengaged as required, thus starting or stopping the endless belt and digger machinery when fitted later.

The frame for carrying the cord controlling the digging arm is built up from four  $7\frac{1}{2}"$  Angle Girders bolted at their lower ends to the inside of the main frames. At the top they are joined together in pairs by means of "T" shaped girders, each of which is constructed from two  $1\frac{1}{2}"$  Angle Girders. The two sides of the frame are then coupled together by a 2" Strip 25. The upper flanges of the "T" girders are fitted at their centre holes with a  $3\frac{1}{2}"$  Rod on which is secured a Coupling 26. The Rod also carries a  $\frac{1}{2}"$  Pinion that is in constant mesh with a Worm mounted on a 2" Rod, carried in the two end holes of a  $1\frac{1}{2} \times \frac{1}{2}"$  Double Angle

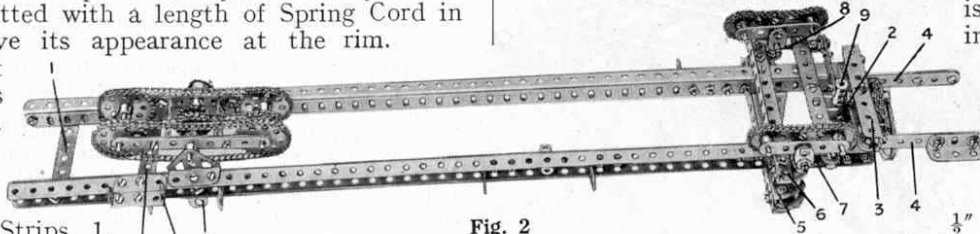

Fig. 2

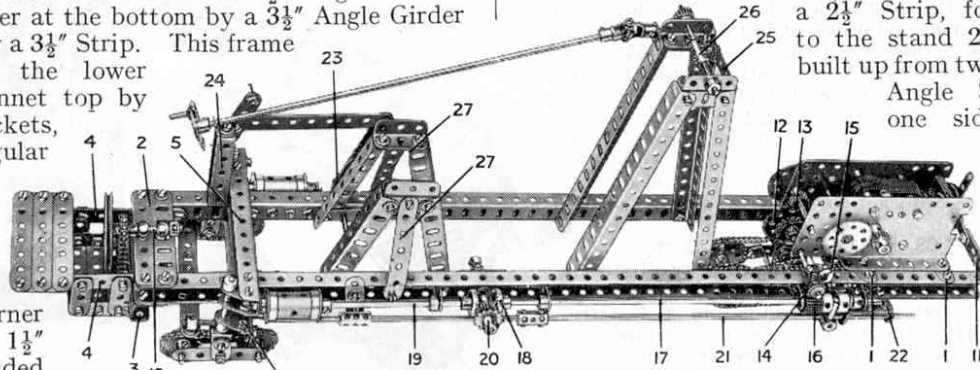

Fig. 3

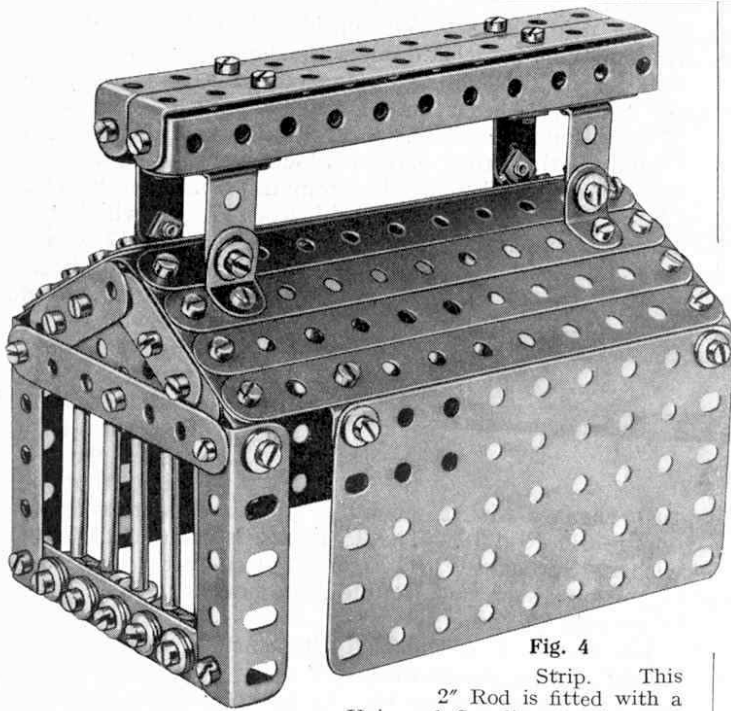

Fig. 4

Strip. This 2" Rod is fitted with a Universal Coupling the free end

of which carries an 11 1/2" Rod journalled in the round hole of a 1/2" x 1/2" Angle Bracket bolted to the top of the stand 24. A handle, consisting of a Bush Wheel and Threaded Pin, is fitted to the end of the long Rod to facilitate turning. This mechanism will be used later for raising and lowering the digging arm.

The structure that carries the digging arm pivot is composed of four 3 1/2" Angle Girders joined together in pairs at the top by "T" girders in a similar manner to the larger frame described previously. The two sides are prevented from moving laterally by means of 3 1/2" Strips 27, the lower ends of which are secured to the main frames by 1/2" x 1/2" Angle Brackets.

The machine is now complete with the exception of the digger arm, and for this Fig. 6 should be referred to. The upper edge of each side of the arm consists of a 7 1/2" Strip to which is bolted a 5 1/2" Flat Girder. One end of the Strip carries a 5 1/2" Strip and the other end a 2 1/2" Strip, both corners being fitted with Cranks, one of which carries the Flat Brackets 32. The lower end of the 5 1/2" Strip carries a 2 1/2" Triangular Plate and a Crank, the Strip overlapping the Plate three holes. The lower edge of the frame is now fitted, and this consists of an 8" strip built up from a 5 1/2" and a 3" Strip. The join between this 5 1/2" and the 2 1/2" Strip, to which it is attached, also carries a Crank. When the frames of the two sides have been completed they are joined together by means of four 1 1/2" Rods secured in the bosses of the Cranks fitted to the corners of the frame. The two lower Rods carry 2" Sprocket Wheels and the two upper Rods 1" Sprocket Wheels, and Collars are placed on each Rod on the opposite side of the Sprocket to the boss so that the wheels all lie centrally.

A 3/4" Sprocket Wheel 28, which drives one of the 2" Sprockets, is carried on a 5" Rod 29 journalled in two bearings each built up from two Flat Brackets arranged in the form of a triangle. These bearings are each secured to a 4" strip, composed of two 2 1/2" Strips, the free end of which is bolted to a long curved strip 30 and a 4 1/2" Strip 31. The strip 30 is built up from two 2 1/2" large radius Curved Strips overlapping two holes. The Strip 31 is fitted with three 3 1/2" Strips arranged as shown in the illustration, the upper strip being secured to the frame, at its upper end, by means of a Flat Bracket and a 1 1/2" Strip. At its

lower end it is held in a channel formed from two 1 1/2" Strips bolted to the two lower 3 1/2" Strips mentioned earlier.

A length of chain is now passed round the four Sprocket Wheels carried on the frame, and to this are secured five Dredger Buckets, representing the digger buckets of the actual machine.

The digger arm is now complete, and is mounted on the model by passing the two ends of the Rod 29 through the centre holes of the "T" girders of the smaller of the two vertical frames. Two Collars are then fitted to prevent side movement of the frame, and a 3/4" Sprocket Wheel is nipped on the long end of the Rod as shown in Fig. 1. This Sprocket is connected to the Sprocket 20 by a suitable length of Sprocket Chain. The Brackets 32 are now connected to the Coupling 26 by two lengths of Cord, Set-Screws in two tapped holes of the Coupling being used for this purpose. Thus by operating the handle, situated on the column 24, it is possible to regulate the depth of cut while the machine is in motion.

Before operating the machine oil should be applied to all the moving parts, and the Sprocket Chain, and the grease cups of the Motor, if these are fitted, must be attended to. The Meccano Lubricating Oil will be found to be most satisfactory for lubricating the model, and Meccano Graphite Grease should be forced into the grease cups.

The model is only suitable for digging in fairly loose material such as gravel and loose earth, but if a more solid discharge belt is used, sand will be found to be most satisfactory. In starting a trench, the bucket arm is lowered until about 1/4" of slack cord is wound off the drum after the bucket arm touches the ground. The endless belt of buckets and also the discharge belt are now set in motion, and as the ground is cleared at the point of contact of the buckets, so the entire machine is moved forward. It is advisable to stop the buckets while a new digging position is found, as the travelling movement of the model is very rapid.

It may be found that the buckets discharge the excavated material clear of the endless belt. This may easily be rectified by fitting small Flat Plates or pieces of cardboard at the necessary points. It may also be found necessary to fit a short chute to one side of the discharging belt so that the waste material is thrown well clear of the trench.

It will be observed that there are only five buckets fitted to the endless belt of Sprocket Chain, whereas many more could be fitted, digging being speeded up in consequence. These extra buckets may be fitted if so desired, but since the model illustrated is intended to come within the limits of a No. 7 Outfit, only five were fitted this being the number included in the Outfit. If more buckets are fitted, however, it will be necessary to speed up the discharge belt.

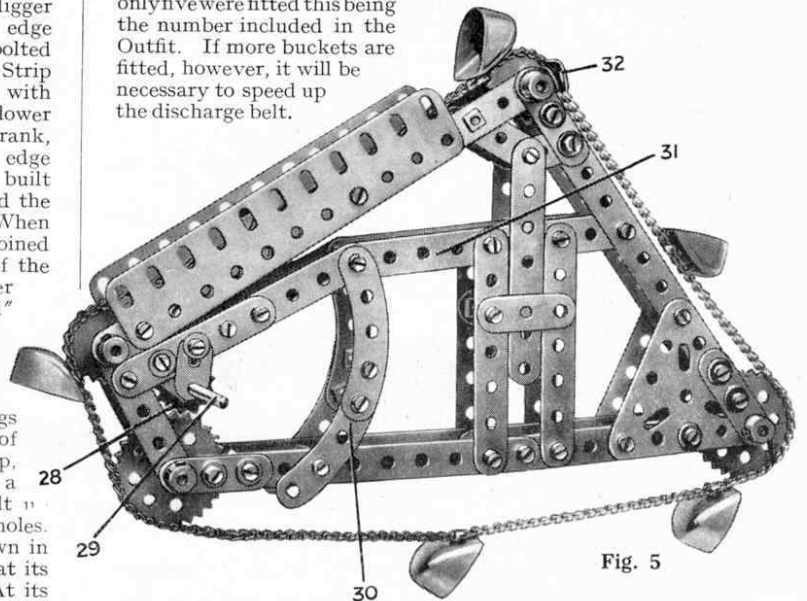

Fig. 5

Parts required to build this Meccano Model

2 of No. 1b	7 of No. 9b	1 of No. 14	1 of No. 25a	2 of No. 53a	8' of No. 94	1 of No. 114
14 " " 2	2 " " 9d	2 " " 15a	4 " " 26	85" " " 58	2 " " 95	2 " " 115
12 " " 2a	2 " " 9e	2 " " 16	3 " " 27a	24 " " 59	4 " " 95a	2 " " 116
14 " " 3	4 " " 9f	5 " " 16a	2 " " 29	9 " " 62	10 " " 96	5 " " 126
5 " " 4	27 " " 10	1 " " 16b	2 " " 39	3 " " 62b	5 " " 96a	3 " " 131
11 " " 5	1 " " 11	10 " " 17	253 " " 37	7 " " 63	2 " " 103	3 " " 133
10 " " 6	11 " " 12	5 " " 18a	29 " " 37a	1 " " 64	2 " " 103d	1 " " 140
14 " " 6a	7 " " 12a	6 " " 18b	166 " " 38	2 " " 76	1 " " 103h	1 " " 144
4 " " 7	4 " " 12b	1 " " 20a	4 " " 48	6 " " 77	4 " " 111	2 " " 163
4 " " 8b	3 " " 13	4 " " 20b	5 " " 48a	2 " " 82	8 " " 111a	1 " " 171
3 " " 9	1 " " 13a	1 " " 24	4 " " 48d	4 " " 90	12 " " 111c	1 E6 Electric Motor