

'STARDUSTER' certainly is a multi-purpose model. It will out-fly most models of a similar size and power and can, if you wish, be fitted up to do crop dusting over your flying field or even drop miniature leaflets over the nearby village! Building 'Starduster' presents no problems. Follow the 'easy-build' sketches and work from the full-size plans provided and in next-to-no time your 'Starduster' will be ready for flying duties. Perhaps you will prefer to fit the crop-dusting and leaflet dropping unit at a later stage, after you have got to know all about trimming and flying this fascinating little aeroplane.

Make sure your fuselage frame comes out square and is not twisted. Also check for warps in your wing, tailplane and fin. To avoid warps it is best to pin the frames down to your building board, using small blocks of balsa to keep the undersurfaces away from the board while the tissue is tightening. This is especially important at the final doping stage. Be careful to drill the nose block at a slight angle when viewed from the top, as shown on the plan. Cement the tailplane in place, *before* fitting the fin. If, when you come to the important business of balancing your model, you find you need some weight in the nose, fit the small radiator as detailed on the plan. This radiator makes a convenient place to hide a small piece of lead or folded cement tube. Cover the wing with five pieces of tissue, two pieces for the undersurfaces and three pieces for the top surfaces (right and left wing panels and centre section). The pilot is optional, but there is no doubt that he greatly adds to the realism of 'Starduster'. The registration lettering can be painted on with enamel paint (if you have a steady hand!) or you can use waterslide transfers obtainable in sheets from your model shop. Take care at each stage of your building and assembly, do not try and rush the construction

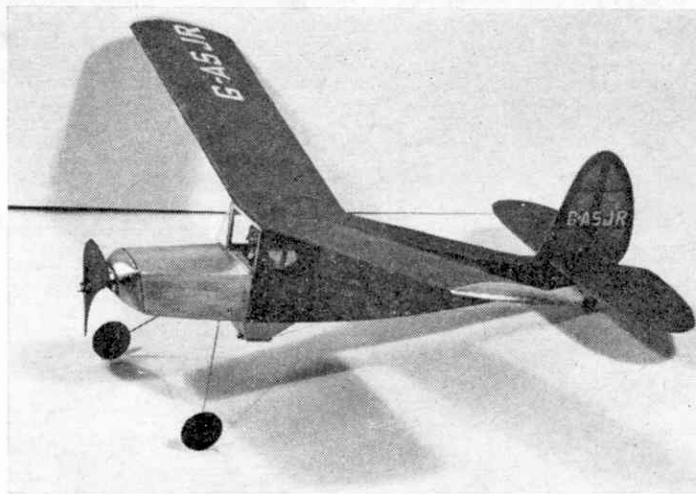

Crop-duster or Leaflet dropper that's

Starduster

a semi-scale rubber powered model
aeroplane by Ray Malmström

and you will be rewarded by a model that not only looks good, but will fly well.

Flying: Install the rubber motor and balance your model as shown. For testing, choose a calm day and some soft grass, then launch 'Starduster' from about shoulder height into the wind. It should glide straight and land about 20-25 ft. away. Turns to left or right can be corrected by *gently* warping the fin

in the opposite direction to the turn. (Model viewed from the rear.) If your model stalls (rears up in a steep climb, falls back on its tail and then dives), add some weight to the nose. If it dives straight into the ground without first climbing, gently bend up the rear edges of the tailplane ($\frac{1}{16}$ in. approx.).

Having obtained a shallow straight glide, connect the free-wheel clutch pin with the winding

hook on the propeller shaft and wind up the motor about 150-200 turns. Please remember to rub special rubber lubricant (6d. a tube from your model shop) into your motor before putting turns on it. *Never* allow oil to come into contact with rubber or it will quickly perish. Launch gently, as before, but let the propeller spin for a second or two *before* releasing 'Starduster'. If, under power, your model flies downward into the ground, stick a small piece of $\frac{1}{16}$ in. square balsa strip along the lower edge of the noseblock. If it stalls, cement a $\frac{1}{16}$ in. square strip along the upper edge of the noseblock. These adjustments alter the angle of the propeller driving shaft (as viewed from the side) and will correct a dive or stall under power without affecting the glide adjustments that you made earlier. When you want to use the crop-dusting leaflet dropping equipment make sure that the rear rubber anchorage dowel rod moves easily in its slot, and that the small dowel rod holding the hopper door closed moves freely in its tape mount. A tiny piece of lead cemented to this door will help it to open easily. Make sure there is no cement or dope on the tape hinge. If there is, it will become stiff and the hopper door will not open. For crop-dusting, you can fill the hopper with flour or yellow powder paint (we have also used 'Ready-Brek' and cold-water paste!). For leaflet dropping cut up some small ($\frac{1}{4}$ in. square approx.) pieces of paper, or use small pieces of coloured confetti. As a rule the hopper door opens towards the end of the flight. You will have to make adjustments to the rubber band that operates the rear-anchorage dowel rod to achieve the best moment for dropping. The tighter the band, the sooner the hopper door will open and vice-versa. As we found out when testing the original 'Starduster', this little model is lots of fun, so—good luck and Happy Flying!

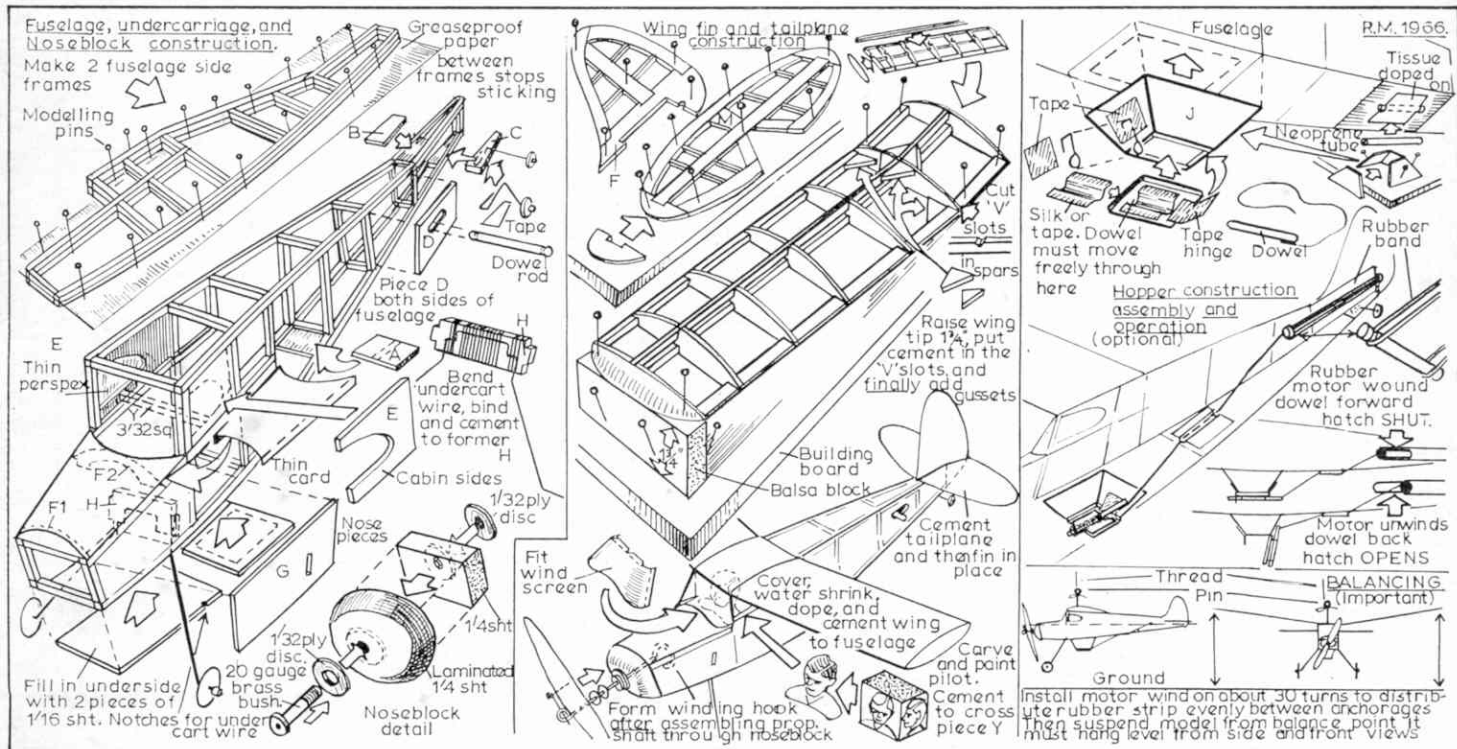

Starduster materials list :

8 lengths 36 in. by $\frac{3}{8}$ in. sq. balsa strip ● 1 sheet 36 in. by 3 in. by $\frac{1}{16}$ in. balsa ● 1 length 12 in. by 3 in. by $\frac{1}{4}$ in. balsa ● 1 small piece 12 in. length of 22 gauge piano wire ● 2 cup washers 20 gauge ● 1 brass bearing bush 20 gauge ● 1 pin ● 1 pair 1 in. diameter propellers (colour to own choice) ● Small piece of thin card ● Small piece of thin perspex or clear celluloid ● 1 medium size tube balsa cement ● 30 in. $\frac{1}{8}$ in. wide rubber strip ● 1 rubber tube lubricant ● 6 in. diameter Keil Kraft hardwood propeller. ● Powder or poster colour (

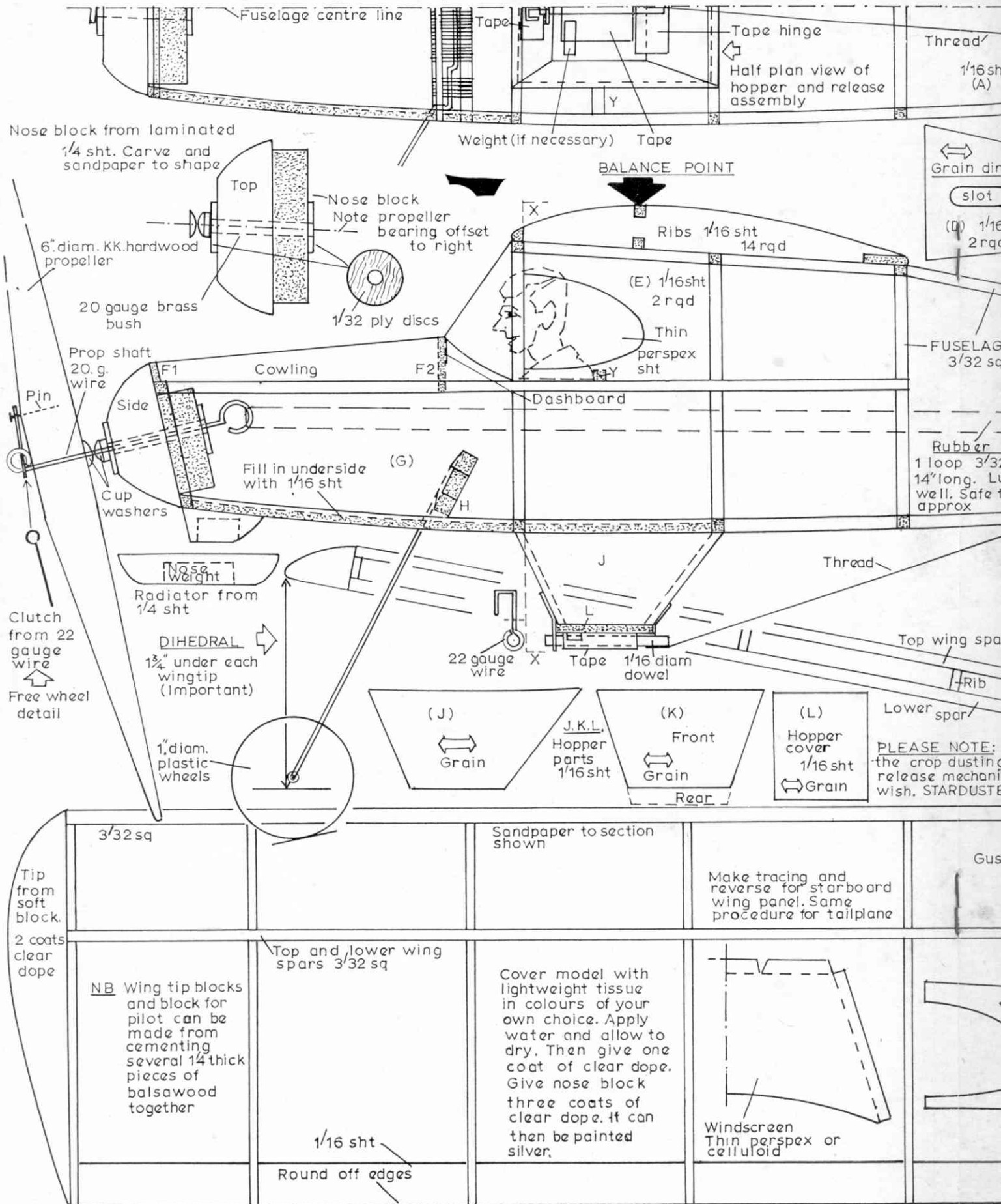

- 1 small piece $\frac{1}{8}$ in. plywood
- 2 in. length of $\frac{1}{8}$ in. diameter hardwood dowel.
- 1 in. length of $\frac{1}{8}$ in. hardwood dowel (or rounded matchstick)
- 18 in. length of 20 gauge piano wire
- 1 in. diameter plastic wheels
- Short length of neoprene tubing
- Short length of electric tubing
- 6 in. length of $\frac{1}{2}$ in. wide linen tape or silk
- 18 in. thread
- 1 sheet lightweight tissue
- Balsa cement
- 1 small tube tissue paste
- 1 small size bottle clear dope
- Small amount of silver dope (for nose sheeting cowling and noseblock)
- 1 3 in. length approx. (rubber band)
- poster colour (for pilot if fitted).
- Sheet of waterslide transfers (registration lettering).

