

The Meccano Motor Chassis

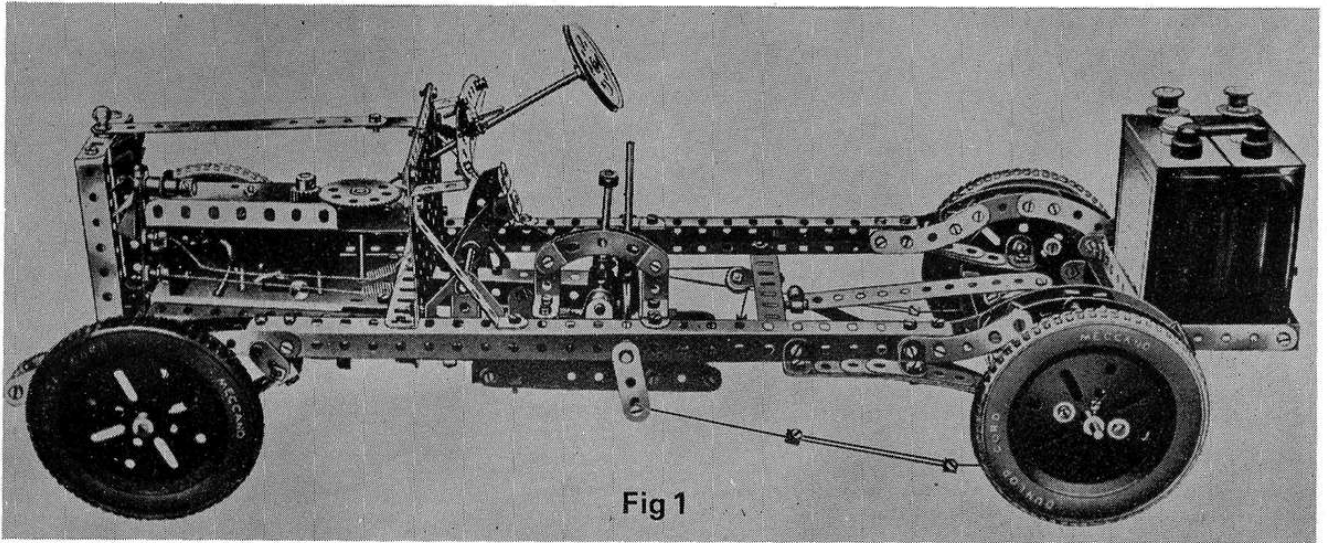

Fig 1

REQUESTS FOR building instructions for Motor Chassis models feature regularly in our mail, so it is with pleasure that we present here an edited version of the most popular Super Model of the late 1920's. Our heading illustration is actually taken from the earlier No.1 Special Instructions Leaflet of 1928 showing the rarer picture of the chassis fitted with the Meccano 8 ampere accumulator of the period. Later leaflets omitted the accumulator, but the building instructions remained unaltered. The Chassis may be built from the standard range of Meccano parts, but a modern electric motor (E15R) is required to replace the original 4 volt motor of 1928. Owing to space restrictions, it has been necessary to split the building instructions into two parts, with Part 1 here and Part 2 following in the next issue.

"Past Masters"

7

Part 1: Chassis Frame & Steering Gear.

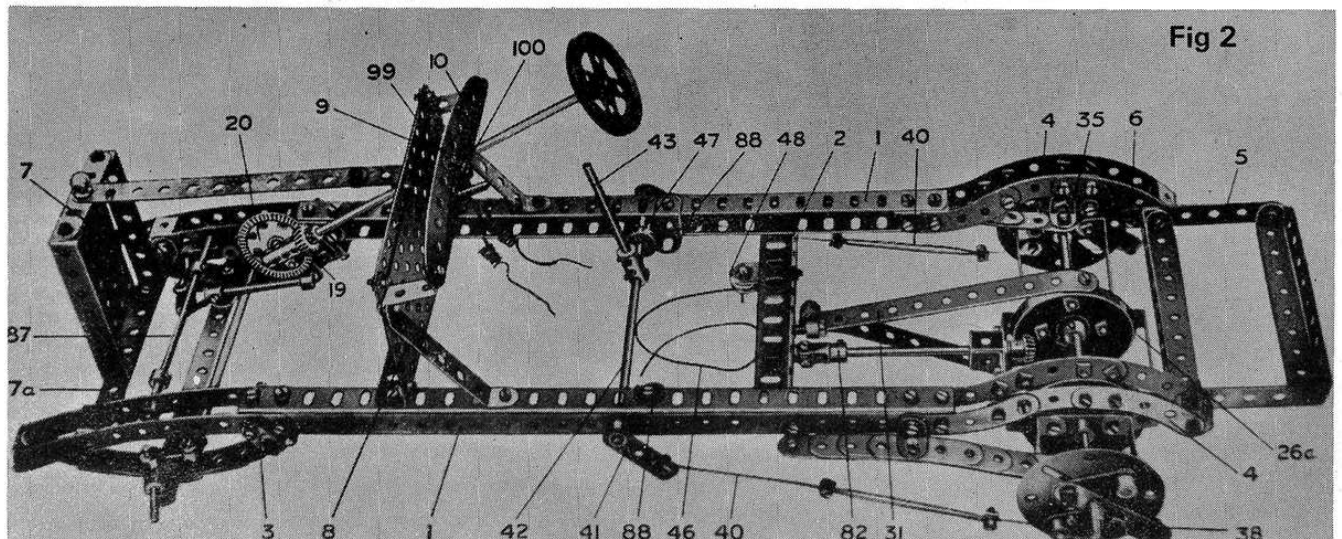

Fig 2

Construction of the model should begin with the main frame which is shown most clearly in fig. 2. Each side consists of two 12½" Angle Girders 1 bolted together in the form of a channel girder to give maximum rigidity. The side girders are held together by a cross member 2, supplied by a 5½" Angle Girder, and their front ends are extended by 5½" Curved Strips to carry the ends of the front semi-elliptic springs. Each inner 5½" Curved Strip is secured to the upper Girder of its respective side member by means of two Angle Brackets. Two of the Bolts that serve to secure the Curved Strips also serve as pivots for the shackles (Fishplates 3) supporting the rear ends of the front springs. The Bolts should be secured to the side members by two locked Nuts so that the Fishplates are quite free to turn on their shanks.

FRAME AND SPRINGS

The main frame is extended and carried over the back axle by means of a series of 2½" large radius Curved Strips 4 bolted together in the manner shown. The luggage carrier 5 is composed of two 3" Strips connected by four 4½" x ½" Double Angle Strips. The carrier is bolted to the end holes in the main frame, and Nuts on Bolts 6 inserted in the end holes of the 3" Strips strike against the Curved Strips 4 and thereby maintain the carrier in a horizontal position. The retaining Bolts are fitted with lock-nuts so that, when the carrier is not in use, it may be folded back.

The radiator is represented by a 3½" x 2½" Flanged Plate 7 with two 3½" x ½" Double Angle Strips bolted at the sides. It is secured to a 4½" Strip 7a mounted between the front 5½" Curved Strips of the frame. A vertically-mounted 5½" x 2½" Flat Plate 8 is secured to a 5½" Angle Girder bolted to the main side Girders 1 and is extended at the top by a 5½" Strip 9 secured at each end by Fishplates. The dashboard 10 consists of a 5½" Strip and a 5½" Curved Strip attached to Plate 8 by means of two 1" Reversed Angle Brackets, the outer ends of which should be bent slightly to obtain the correct angle for the dashboard. (By using a 5½" Insulated Strip from the Electrical Set instead of the standard Strip across the dashboard, a Fishplate fitted with a Threaded Pin may be lock-nutted to its centre to act as a simple contact-to-chassis switch for the Meccano Electric Motor.)

It will be seen from fig. 5 that the front springs are of the semi-elliptic type, and that each consists of one 5½", one 4½", one 3½",

Opposite page: Fig. 1, an illustration of the original Meccano Motor Chassis reproduced from the No. 1 Special Instructions Leaflet of 1928; Fig. 2, a view of the frame showing springs, steering column, brakes and rear axle with differential removed. Right, Fig. 3, the front end of the chassis showing the steering mechanism.

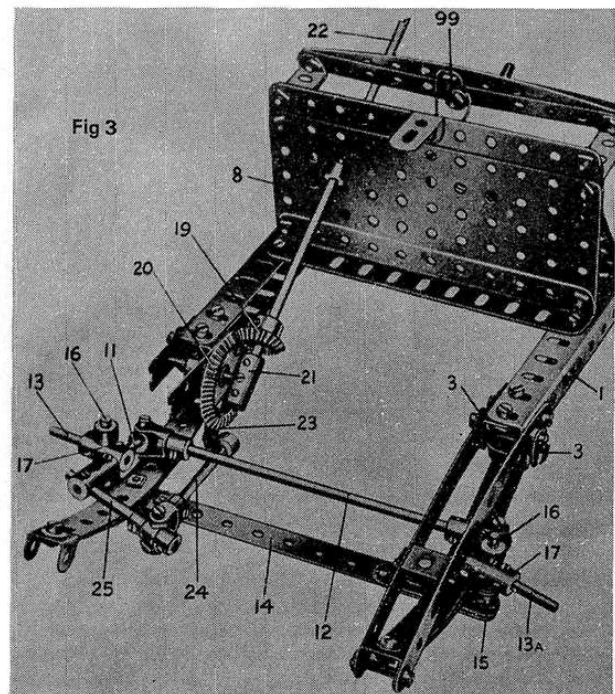

one 2½" and one 1½" Strip, placed one upon the other and slightly bent. Each end of the 5½" Strip is secured to a Double Bracket, the rear Double Bracket being bolted pivotally to Fishplates 3 and the front Double Bracket being mounted on a ¾" Bolt passed through the side frame members. Rear springs are of the cantilever type, and one of them is shown in detail in fig. 6. Each spring is built up from the same components as the front springs and is attached rigidly to the frame by Angle Brackets.

CHASSIS STEERING GEAR

In Meccano practice it has been found a little difficult to secure the necessary angles in the levers and at the same time maintain a perfectly rigid construction, and therefore a slightly different method has been adopted. This comprises short Rods 11 and 11a secured just behind the stub axles and protruding backwards. They are connected together by a 5"

Rod 12. A plan view of this linkage is shown in fig. 4 and it will be seen from the drawing that imaginary lines, AB and CD, drawn through the pivotal mountings of the stub axles and through the points where the tie-rod 12 is attached to Rods 11 and 11a correspond roughly to the angles at which the levers would be placed in actual practice. Thus, this arrangement of the linkage fulfils the essential requirements of the Ackermann steering gear, i.e. it imparts a greater angular movement to the inner road wheel when the car turns a corner.

Mounting of the stub axles 13a is shown in detail in fig. 5. The fixed front axle 14 consists of two 5½" Strips overlapped nine holes and supporting a Crank 15 at each end. A 1½" Rod 16, secured in each Crank, serves as a vertical swivel pin upon which a Coupling 17 carrying the stub axles (a 1" Rod) is free

Fig. 4, plan of steering mechanism which follows the Ackermann principle.

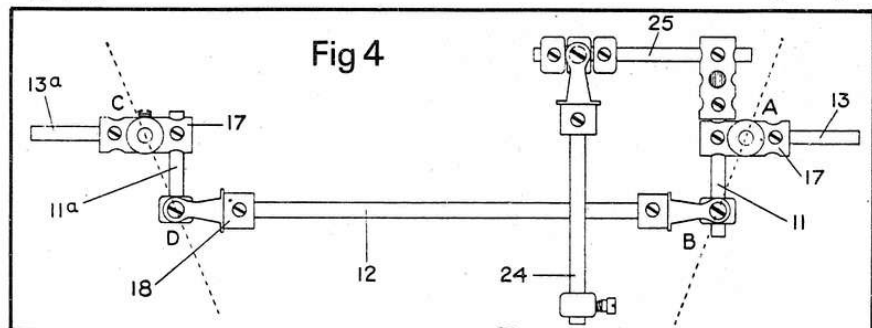



Capturing for posterity – the Author filming a model negotiating a difficult obstacle as it moves into action. Readers may recognise the model as the Self-propelled Gun described in the July '74 MMQ.

focussing facilities, and for those that don't focus near enough, then one or two supplementary lenses may be required. These may cost from 75p upwards, depending upon the camera in use.

TECHNIQUE

The technique for filming your model is quite straightforward. It is best if the camera is clamped to some rigid

support to give a nice steady picture when eventually it is projected. A tripod stand is ideal and also excellent examples of camera stands can be simply made – in Meccano of course!

It is usually best to begin with an overall view of the model. This is obtained by placing the camera well away from the subject so that the entire model is seen. This shot should be approximately 12 - 20 seconds in duration to give the audience time to take in some of the details. Then the camera can be moved to show the model from different viewpoints. Now, move in closer to show the details more clearly. Set the mechanism in motion. Keep changing the angle of view. In fact, one golden rule of filming is to *change the camera position for each shot*. You can return to a previous camera position in subsequent shots if required. This golden rule avoids a disturbing phenomenon which is known in filming circles as the "jump cut", when moving objects take a sudden inexplicable leap forward in the middle of an otherwise smooth action.

DURATION

The overall duration of the film should be sufficient to allow you to comment on important details and give interesting facts and figures about it while it is being shown to your audience. Your comments need to be brief and to the point, otherwise you will use up a lot of film. If you wax eloquent on the subject of your model (and who doesn't?) you need to curb your enthusiasm and keep your comments brief, or you will find that it is cheaper to stick to slides (transparencies)!

If the filming bug really bites you can put your comments onto a proper soundtrack on the film and also add appropriate sound effects for your models, but this is deep water for the novice to filming. A well-made silent film is perfectly adequate with a commentary by the projectionist. I have made several short films featuring my models and treasure them? Why don't you give it a try? Incidentally, I have found Meccano to be a great help in my hobby of film-making for the construction of such things as camera stands, trick titlers, a psychedelic film machine, a lapse timer and so forth. I wonder if other Meccano aficionados have any further examples to offer of the use of Meccano in connection with filming, or photography in general?

MOTOR CHASSIS PARTS REQUIRED

See Pages 20-22

11- 2	2-14	2-25	9- 48A	2-109
9- 2A	2-15	4-26	2- 48B	5-111
4- 3	1-15A	2-27	4- 48C	8-111A
6- 4	5-16	1-27A	1- 53	9-111C
6- 5	2-16A	1-28	1- 55A	1-115
9- 6A	1-16B	4-30	3"-58	2-120B
4- 8	5-17	2-30A	42 -59	4-124
2- 8A	5-18A	2-30C	5- 62	2-125
2- 9	3-18B	4-31	9- 63	2-126
12-10	4-19B	178-37	1- 70	1-136
8-11	1-20	38-37A	5- 89	4-137
24-12	1-20A	40 -38	14 -90	2-140
4-12A	3-22	1- 45	2- 90A	4-142B
4-12B	2-23	1- 46	4-101	2-147B
1-13A	1-23A	2- 47	1-102	1-155
2 6BA Screws, 2 6BA Nuts,				
2 Insulating Bushes, 2 Insulating Washers, 1 E15R Electric Motor.				

LUNAR BUG PARTS REQUIRED

See Page 10

13- 2	1-23a	2- 53a	1-190
2- 3	1-24	2- 54	1-191
4- 5	1-26	2- 99	4-192
3-11	2-27f	1-111c	1-193c
1-11a	107-37b	1-115	2-194
7-12	108-37c	2-125	1-199
1-12a	16-38	2-126	1-200
8-12c	2-48	2-126a	1-212
1-15	8-48a	4-187	1-213
1-19s	1-51	4-188	2-214
1-23	1-52	2-189	2-221

PROPOSED NEW MECCANO CLUB

Interesting news for Meccano modellers in the Portsmouth area of the Country – Mr. Tony Rednall, of Denmead, Hants., would like to get together with other enthusiasts in the area with a view to forming a new Meccano Club. He would be pleased to hear from anybody interested and can be contacted at 4 Mount Pleasant, Mead End Road, in Denmead.

* * * * *

The Editor and Staff of the Meccano Magazine Quarterly wish

* all our readers, contributors and advertisers a happy, prosperous *
and peaceful year throughout 1976.

* * * * *

The Meccano Motor Chassis

"Past Masters"

7

Part 2: Gearbox, Transmission, Brakes and Differential.

PART 1 of this fully constructional feature, describing the famous Meccano Motor Chassis of the 'twenties, was published in the January 1976 edition of the MMQ. In Part 2, here, we complete instructions for installing the mechanics of the Chassis, although in some cases it will be necessary to refer to pages 20-22 of the January magazine, where Fig. Nos. 1-7 appear. All the illustrations in both Parts of this feature are copied from the original No. 1 Special Instructions Leaflet of 1928. A list of the parts required to build the model also appears in the January magazine.

BRAKE MECHANISM

One of the rear wheel brakes is shown in detail in Fig. 8, and it will be seen that it is of the internal expanding type. Two $\frac{1}{2}$ " Bolts are passed through opposite slots in Face Plate 30 and their ends, after passing through $1\frac{1}{2}$ " Strips 36, are secured in Collars 37 which form the brake shoes. Each $\frac{1}{2}$ " Bolt carries a Washer under its head and two on its shank between the Face Plate and Strips 36. The latter are pivoted by means of Bolts and lock-nuts to a $2\frac{1}{2}$ " Strip 38, free to turn about Axle Rod 27. When the $2\frac{1}{2}$ " Strip is moved, the Collars are thrust outward along the slots by means of Strips 36 and are pressed against the inside periphery of a Wheel Flange 39 bolted to the inside of the road wheel. Three Washers should be placed on Axle Rod 27 between Strip 38 and the Face Plate. Care should be taken to see that the $\frac{1}{2}$ " Bolts are able to move quite freely to and fro in the slots of the Face Plate.

The Grub Screws in Collars 37 are replaced by standard Meccano Bolts, and these are used to secure a short length of Spring Cord. This serves to

withdraw the brake shoes 37 and return the brake to the "off" position when Strip 38 is released. The Road Wheel should be placed on Axle Rod 27 with Wheel Flange 39 towards Collars 37, care being taken to see that the latter have plenty of room to move before the Road Wheel is secured rigidly to the Axle.

In the original Super Model, each Brake Rod 40 consisted of two Meccano Loom Healds bolted together (as shown in the illustrations), but a length of Cord will serve almost as well in their place. Following the illustrations, however, the Healds are connected pivotally at one end to Strip 38 by means of a Bolt and two Nuts and, at the other end, by a similar method to a Crank 41 secured to a $6\frac{1}{2}$ " Rod 42. This Rod carries a hand lever 43 (a $2\frac{1}{2}$ " Rod) by means of which the brakes are operated.

A second brake is fitted to the chassis and is operated by the foot pedal 44, the mounting of which is clearly shown in the general view of the power unit. The lever consists of a $2\frac{1}{2}$ " Curved Strip pivotted by its centre hole to a $3\frac{1}{2}$ " Rod 45 journalled in Trunnions. A length of Cord 46 is

tied to the second hole of the lever and is led under the $\frac{1}{2}$ " loose Pulley 47, round a second $\frac{1}{2}$ " Pulley 48 (mounted on a Pivot Bolt secured in the end of a Single Bent Strip bolted to cross member 2) and thence round the groove of a 1" Pulley 49 secured to the cardan shaft. The Cord is finally brought back and tied under the head of the Pivot Bolt carrying Pulley 48. A slight pressure on pedal 44 tightens the Cord round Pulley 49 and thereby retards the motion of the cardan shaft. When the brake is off, the lower portion of the pedal rests against a $\frac{3}{4}$ " Bolt 50 secured in one of the Trunnions, and the pedal is held thereby in a convenient upright position.

POWER UNIT

In the original model, a 6 volt long-sideplate electric motor was employed (in some cases a 4 volt unit), but the modern E15R motor may be substituted. In either case, the motor is mounted lying on its side and those constructors who have the older motor will be able to follow the original instructions reproduced here. As the E15R motor has shorter sideplates, however, this will need an extra $2\frac{1}{2}$ " Strip bolted across the main frame of the engine unit just in front of the one shown in Fig. 10 and numbered 54. The motor represents the car engine, of course, and it is bolted as a rigid unit to the engine frame which in turn holds the clutch and gearbox in a similar rigid fashion. This complete unit forms the compact sub-assembly which can be easily aligned from the motor to the first universal joint and it may be removed from the main chassis of the motor car simply and quickly. This method

Fig. 8, the internal expanding rear wheel brake, ready for assembly. The obsolete Healds (40) can be replaced with cord or wire.

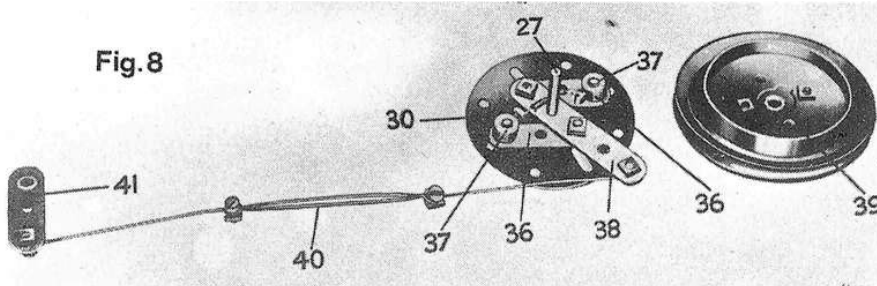

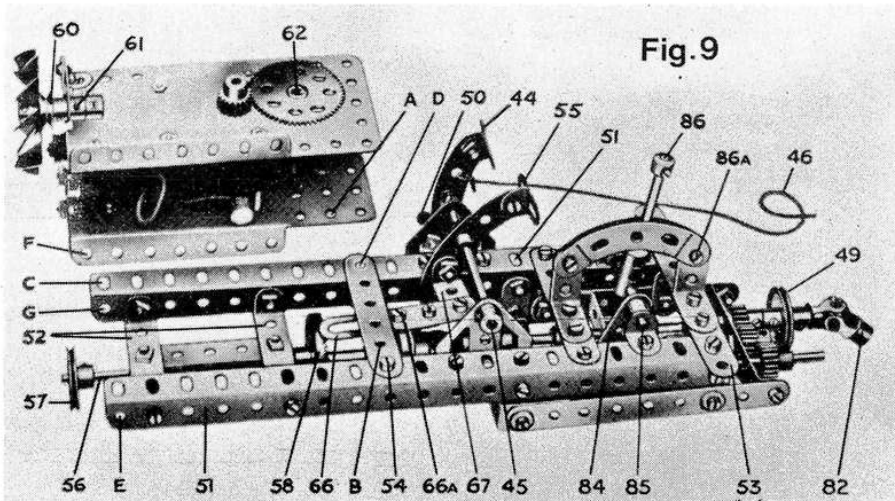

Fig. 9, a general view of the power unit, with the motor detached. An E15R Motor can be used in place of the obsolete motor illustrated.

of construction ensures that the Gear Wheels and other working parts will always be in proper alignment with each other, and that their functions will not be affected in any way by stresses and strains set up in the chassis frame.

The main frame of the unit consists of two 9½" Angle Girders 51 connected together by two 2½" x ½" Double Angle Strips 52 and 4½" Strip 53. The motor is secured to the frame by a Bolt passing through hole A in its side and hole B in a 3" Strip 54, and by two other Bolts engaging holes C and D of one of the 9½" Girders. Three Washers are placed on each of these Bolts between the motor and the frame. The motor rests on the far side 9½" Angle Girder (Fig. 9) only, to which it is bolted. The near 9½" Angle Girder is not attached to the motor except by Strip 54.

A 2½" x ½" Double Angle Strip bolted across Double Angle Strips 52 forms a bearing for a 5" Rod 56, which corresponds to the crankshaft of an actual car. This Rod carries a 1" fixed Pulley 57, a 1½" Contrate Wheel 58 and a 1" fixed Pulley 59. A length of Cord connects Pulley 57 with ½" fixed Pulley 60 secured to the shaft of the radiator cooling fan, which is free to rotate in the boss of a Crank 61. The latter is bolted by its end hole to an Angle Bracket secured to the top of the motor.

TRANSMISSION - THE CLUTCH

Drive from the motor armature is first led to a secondary shaft 62, on the lower end of which is secured a ½" Pinion, boss downwards, engaging with Contrate Wheel 58. Pulley 59 on Rod 56 forms the male portion of the clutch and is fitted with a Meccano

Rubber Ring which provides the resilient surface required in a frictional contact clutch of this type. The female clutch member consists of a Flanged Wheel 63, with Set Screw removed, placed on the end of a 3½" Rod 64.

The Flanged Wheel must slide on Rod 64 and yet be mounted in such a way that, when it is engaged by the clutch member 59, it transmits power to Rod 64. This is accomplished by two Angle Brackets bolted to the Flanged Wheel by 3/8" Bolts, from which they are spaced by Collars. Passed through the elongated holes of the Angle Brackets are two Set Screws inserted into the "spider" of a Swivel Bearing, secured to Rod 64 and separated from Flanged Wheel 63 by a portion - approximately half - of a Compression Spring 65a. The Spring normally holds the Flange Wheel in contact with the Rubber Ring on Pulley 59, but the Flanged Wheel can be forced back on Rod 64 to an extent just sufficient to throw it out of contact with the clutch member 59.

The clutch withdrawal mechanism consists of a 2" Slotted Strip 66 bolted to a 1½" Strip, the latter in turn being bolted to a 1" x ½" Angle

Bracket 67 that is connected by a Bolt and Lock-nuts to the second hole of pedal 55. The slot of Strip 66 engages Rod 62 immediately behind the Pinion driving Contrate Wheel 58, Rod 62 thus forms a guide for Strip 66, which moves in a direction parallel to Rod 56. It will be found that when pedal 55 is depressed, the shank of Bolt 66a engages with the rim of Flanged Wheel 63, and the latter is thereby withdrawn from contact with clutch member 59.

GEARBOX

The gearbox provides three speeds forward, neutral and reverse gears. It is built up from two 4½" Strips connected together at the front end by a 2½" x 1½" Double Angle Strip and, at the other end, by a 2½" x ½" Double Angle Strip. It is secured to Angle Girders 51 in the position shown by means of four Fishplates.

Rod 64, carrying the clutch member, represents the primary driving shaft. It is provided with a ¾" Pinion 68 and a 1" Gear Wheel 69, and its inner end is journaled in a 1" x 1" Angle Bracket 70. The countershaft consists of a 6½" Rod 71, sliding in the end Double Angle Strips of the gearbox. This Rod carries, in order from left to right in Fig. 11, two Collars (acting as stops to limit its sliding movement), a 50-teeth Gear Wheel 72, a 1" Gear Wheel 73, two more Collars, one of which (74) is free on the Rod, a ¾" Pinion 75, a 1" Gear Wheel 76 and a ½" Pinion 77. These parts should be secured carefully in the positions indicated in Fig. 10.

The driven 3" Rod 78 is journaled in the end Double Angle Strip of the Gearbox and in a second 1" x 1" Angle Bracket 70a. It carries a 50-teeth Gear Wheel 79, a 1" Gear Wheel 80, a ½" Pinion 81, the brake Pulley 49 and a Universal Coupling 82. A Washer should be placed between Pinion 81 and the Double Angle Strip. Pinion 81 is in constant mesh with

Fig. 10, a plan view of the 3-speed-and-reverse gearbox and friction clutch.

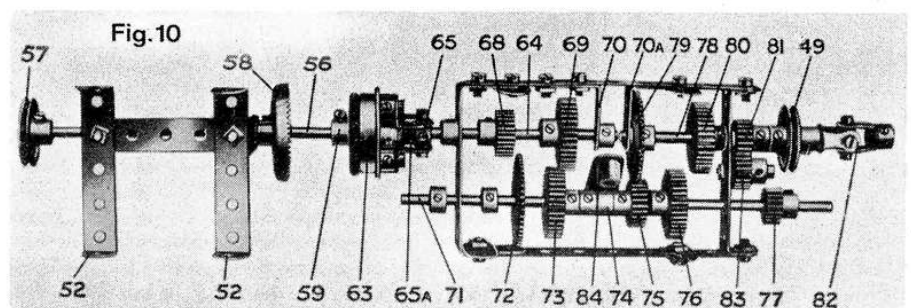

"Past Masters"

Continued from Page 51

another 1/2" Pinion 83, free to rotate upon a 3/4" Bolt secured to the end Double Angle Strip by two Nuts.

A standard Meccano Bolt passes through the elongated hole of Crank 84, is fitted with a Nut and then screwed into the threaded bore of Collar 74. The Nut is secured tightly against the Collar in order to prevent the bolt shank fouling Rod 71 and also to ensure that the Crank is quite free to pivot on the Bolt. The Crank is secured to a 2" Rod 85 journalled in Angle Brackets bolted to Angle Girders 51 of the power unit, and a Coupling secured to this Rod carries the gear-change lever 86. It will be seen that the lever moves in a quadrant constructed from two 2 1/2" Curved Strips bolted one on each side of 1" x 1" Angle Brackets secured to the top of the power unit. The Curved Strips are spaced away from each other by the thickness of the supporting Angle Bracket and one Washer placed on each connecting Bolt. In this way, the Curved Strips are caused to apply a certain pressure to lever 86, sufficient to hold the lever firmly in position after each change of gear is effected.

To mount the power unit in the chassis, the radiator is first removed by unscrewing Strip 7a on which it is mounted. Bolt 86a is removed from the gear-change lever quadrant and 5" Rod 87 is drawn out. The power unit is now positioned and the end holes of Strip 53 are bolted to the Reversed Angle Brackets 88, after which Rod 87 is replaced, passing it through holes E, F and G of the motor and power unit frame. Collars on Rod 87 are next screwed tight against the power unit and Bolt 86a is replaced in the gear lever quadrant. (This Bolt was removed merely to obviate the necessity of removing Rod 42 which passes through the centre of the quadrant.) The radiator is then replaced and the Cord 46 of the foot brake is secured in the position previously described.

DIFFERENTIAL GEAR

Construction of the differential frame will be obvious from Fig.11. The two 2 1/2" x 1 1/2" Double Angle Strips shown in this illustration may also be seen in Fig.7, but in the latter case, they are shown bolted to Wheel Flanges 26 and 26a incorporated in the back axle casing. When the gear is ready to assemble, the

differential frame (formed by the 2 1/2" x 1 1/2" Double Angle Strips and 3" Strips 26b) should first be incorporated in the fixed back axle, after which the gearing should be placed in the frame and the shafts 27 and 28 inserted in their respective positions. It will be noticed a Washer is placed beneath the head of the Bolts at each corner of the differential frame, this being to prevent the shanks of the Bolts fouling the sides of the Wheel Flanges.

The back axle shaft is in two sections, 27 and 28. The former consists of a 3" Rod and the latter of a 4 1/2" Rod and a 2" Rod connected end-to-end by a Coupling, as shown. The inner ends of shafts 27 and 28 are journalled in opposite ends of a Coupling 89, in the centre transverse hole of which is secured a 2" Rod 93 that carries two free-running 7/8"

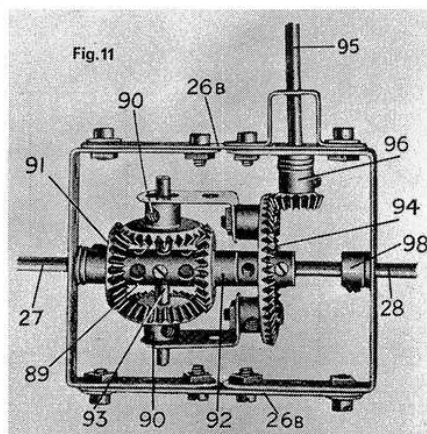

Fig. 11, the differential mechanism.

Bevel Gears 90. These Bevels engage with two similar Bevels 91 and 92 fixed on shafts 27 and 28, respectively.

The outer ends of the 2" Rod carrying Bevels 90 are passed through the elongated holes of 1" x 1 1/2" Angle Brackets, the latter secured rigidly by 1/2" Bolts to opposite holes in a 1 1/2" Bevel Gear 94, from which they are spaced by Collars on the fixing 1/2" Bolts. Bevel Gear 94 is free to revolve on shaft 28.

The propeller shaft consists of 3 1/2" Rod 95, one end of which is secured in Universal Coupling 82 and the other end, after passing through a Double Bent Strip and the side of the differential frame, is secured in a 1/2" Bevel Gear 96, engaging with Bevel 94. Two Collars 98 are secured to shaft 28 in the position shown to keep the various Gears in correct alignment and to prevent Gears 94 and 96 from slipping or binding against each other. A Washer should be placed between outer Collar 98 and the Double Angle

Strip of the differential frame, and two Washers should be placed between the boss of Bevel Gear 91 and the frame.

Care should be taken to see that the various parts of the differential gear work quite freely and that the several Bevel Gears are all placed in the correct positions in relation to each other. Everything should operate smoothly and easily when shafts 27 and 28 are twisted between thumb and finger, whether simultaneously and in the same direction, or separately and in the opposite direction.

ELECTRICAL CONNECTIONS

For those constructors adhering to the original specifications, the leaflet text is as follows:

All that now remains to complete the model is the wiring between the motor, dashboard switch, and the accumulator. Either the Meccano 8 amp or 20 amp accumulator may be used, but the former is of a more convenient size. As previously pointed out, it may be mounted on the luggage carrier at the rear of the model.

One wire should be led direct from the motor terminal to one terminal of the accumulator, and another wire should be led from the second motor terminal to a 6BA bolt 99 secured to the dashboard. This bolt is insulated from the 5 1/2" Curved Strip of the dashboard by means of a Meccano Insulating Bush and Washer. The switch handle consists of a Threaded Pin secured to a Fishplate 100, which is attached to the dashboard by another 6BA bolt. An ordinary metal washer should be placed on each side of the Fishplate, but the bolt is insulated from the dashboard by means of an Insulating Bush and Washer. A wire secured to its shank is led to the second terminal of the accumulator. The motor is started by sliding Fishplates 100 over the head of bolt 99, thus completing the electrical circuit.

Coming back to the present day, if a different motor to that described is used (up to 20 Volts), the same bare chassis connection for one lead may be used from a transformer. However, *this switching dashboard arrangement must not be used if a mains motor (115-240) volts is employed to drive the model.*

PART LIST

The complete list of parts required to build the Meccano Motor Chassis was given in Part 1 of this article, published in the January MMQ.