

Now you can really get weaving with this...

POWER LOOM

A Classic from the 'Fifties

A WORKING LOOM is among the most impressive of all Meccano models. Its synchronised precision movements are fascinating to watch; its business-like metallic chatter is music to the mechanically-tuned ear. But, most important of all, it gives the builder the ultimate satisfaction of seeing his creation actually weave real cloth.

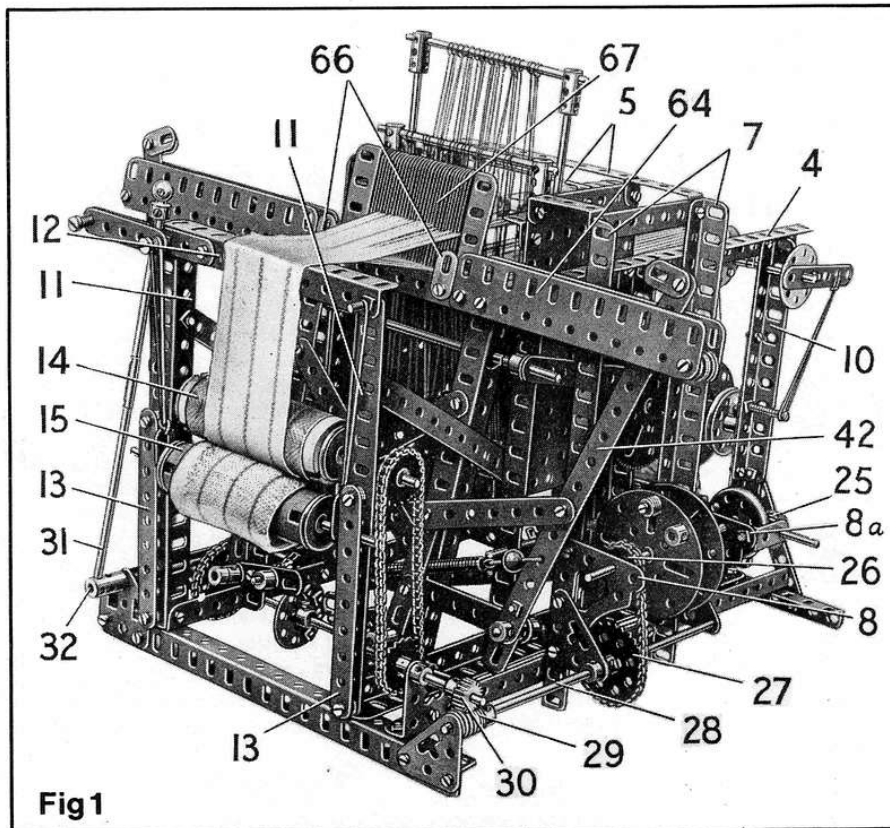

Fig 1

For this, the fourth article in our 'Past Masters' series, we have chosen a powered Loom which was originally featured in the December 1953 and January 1954 issues of the M.M. In fact, the accompanying illustrations are the actual original photographs, found in a dusty old file! The model has the advantage of being fully operational, with minimum complexity and, in our opinion, it qualifies as a Meccano Classic.

These are, however, two problems: (1) The Healds necessary for successful operation are now obsolete and no longer available, and (2) we don't have the space here to print the building instructions! Not to worry though; the first problem is solved with the special Meccano Heald-making Machine featured on Page 72 and, to solve the second problem, we have printed the building instructions separately. To obtain a copy, please send an S.A.E. (overseas, two International Reply Coupons) to Meccano Magazine Quarterly, Binns Road, Liverpool L13 1DA. (We regret we can supply only one free copy per subscriber; thereafter 10p for each additional copy). Get weaving!

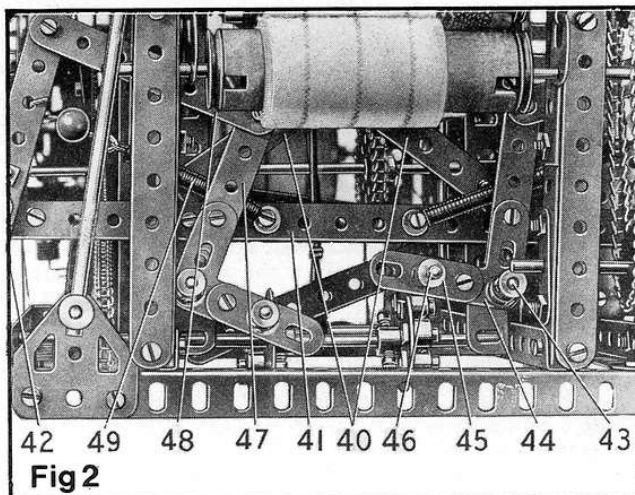

Fig 2

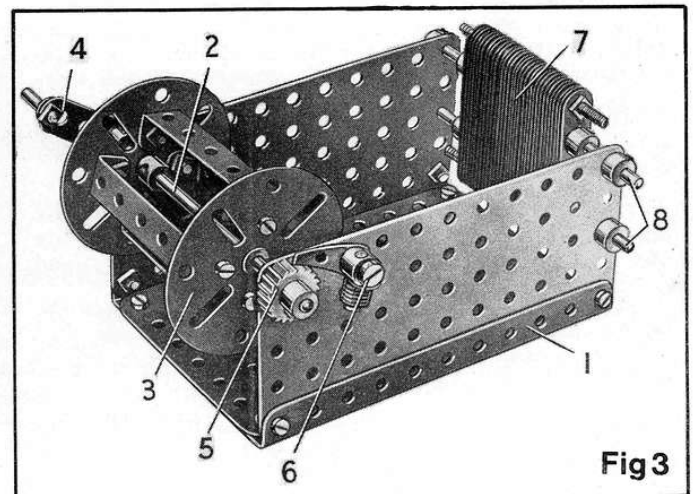

Fig 3

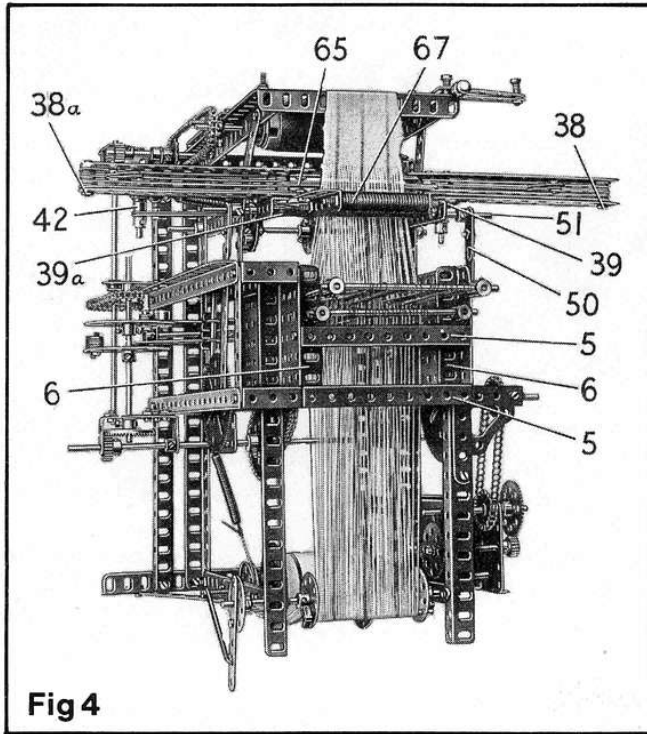

Fig 4

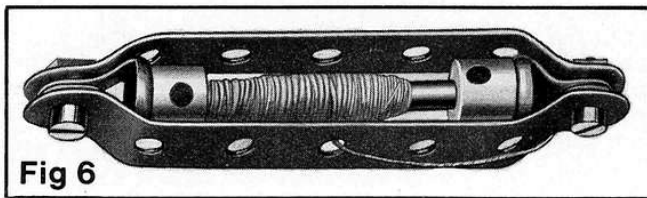

Fig 6

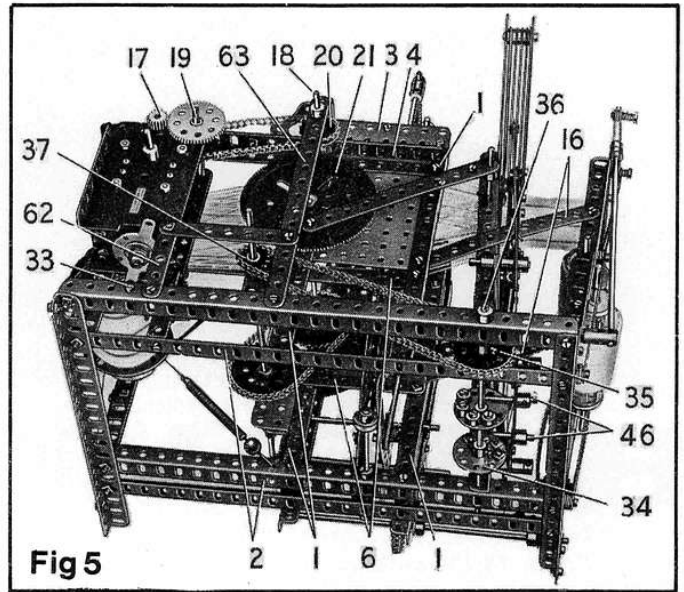

Fig 5

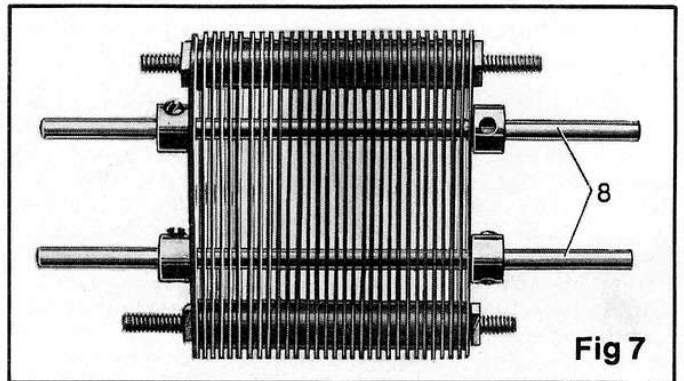

Fig 7

Past Masters NUMBER FOUR

Fig. 1, a general view of the Meccano Loom showing its compact appearance.

Fig. 2, a close-up view of the cam mechanism that operates the picking sticks.

Fig. 3, the Beaming Frame – a useful accessory for preparing the beam of warp thread for insertion in the Loom.

Fig. 4, an overhead view of the model showing the arrangement of the shuttle race.

Fig. 5, an underside view showing details of the frame and the mounting for the E15R Electric Motor. (A now-obsolete E20R Motor was used in the original model).

Fig. 6, the Shuttle which is built up from standard Meccano parts.

Fig. 7, the Reed used in the Beaming Frame.

Fig. 8, a low-angle side view of the Loom showing the cams controlling movement of the heald frames. The healds, themselves, are now obsolete, but adequate substitutes may be made using the special machine featured overleaf.

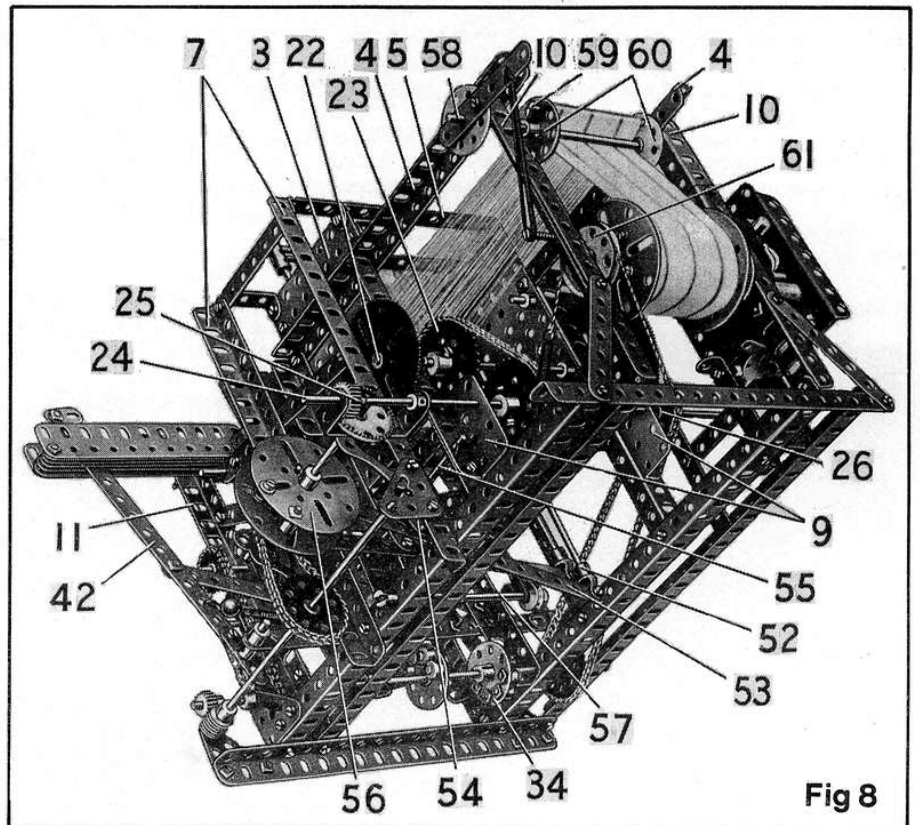
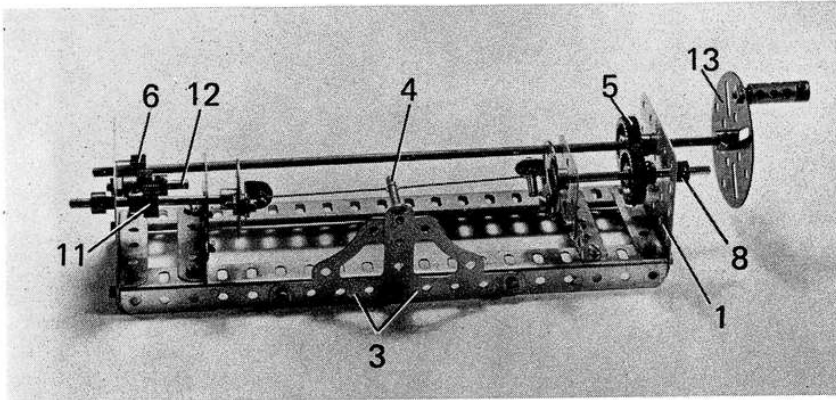

Fig 8



Spanner solves a 'Past Masters' problem with this specially designed model

HEALD~MAKING MACHINE

BEING A TRUE working model, the Meccano Loom featured on the two previous pages makes use of healds to carry and manipulate the warp threads during weaving. The healds are vital components, but unfortunately, since the model was first published twenty years ago, the purpose-made Meccano Heald (Part No. 101) which was included in the system has been discontinued. Lesser magazines might be discouraged by this, but not so the MMQ; if it isn't made, make it, we say, and the machine described here is designed to do just that!

Making your own healds sounds a daunting prospect, but in fact it is remarkably easy and the machine required for the job is simple, as can be seen from the illustration above. A solid frame work is produced from two 9½" Angle Girders, connected together at each end by a 2½" Angle Girder, the securing Bolts in each case also fixing a 2½" x 2½" Flat Plate 1 in position. Two more 2½" Angle Girders are bolted between the 9½" Girders, one through the third holes in from each end, and bolted to each of these is a 1½" x 1½" Flat Plate 2. Centrally fixed to one of the 9½" Girders are two Corner Gussets 3, overlapped as shown, a Long Threaded Pin 4 being tightly locked in the apex holes of the Gusset.

Journalled in one set of upper corner holes of Flat Plate 2 and in

Close-up of one Bush Wheel assembly

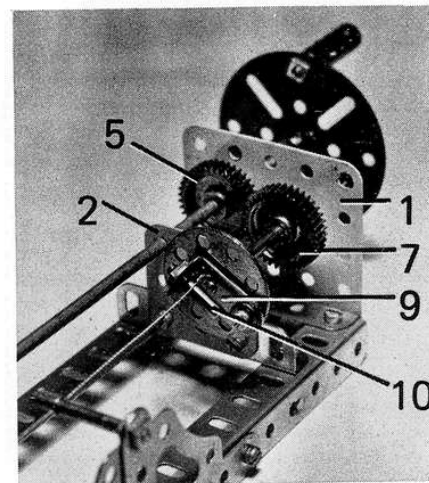

the corresponding holes in Flat Plate 1 is an 11½" Rod, held in place by a Collar and a 1" Gear Wheel 5 at one end and by a ½" Pinion 6 at the other end. Gear 5 meshes with a second 1" Gear 7 on a 3" Rod journalled in the remaining upper corner hole of nearby Plate 2 and in the corresponding hole in Plate 1. This Rod is free to move approximately a quarter-inch in its bearings, but it is held in tension by the action of a Compression Spring positioned on the Rod between the back of Plate 1 and a Collar 8. Mounted on the inner end of the Rod is an 8-hole Bush Wheel, to the face of which a 1" x ½" Angle Bracket 9 is fixed by its long lug, with the end of the Rod just protruding through the inner hole in the lug. A Threaded Pin 10 is fixed to the short lug of the Angle Bracket.

A similar Threaded Pin / Bush Wheel construction is built up and mounted on the inner end of another 3" Rod journalled in corresponding holes in remaining Plates 1 and 2. Again, the Rod is free to slide a short distance in its bearings, being held in tension by a Compression Spring and Collar, but this Rod carries a ½" Pinion 11 instead of the previous 1" Gear. The Pinion meshes with a second ½" Pinion which is free to revolve on a Long Threaded Pin 12, locked in the second row centre hole of Flat Plate 1. The Pinion, which is prevented from sliding on the Pin by a Collar, also meshes with Pinion 6 on the 11½" Rod. As a result, when the 11½" Rod is revolved, the two Threaded Pin/Bush Wheel constructions contra-rotate (revolve in opposite directions in relation to

each other). A winding handle for the long Rod is provided by a Face Plate 13, to which is fixed a Long Threaded Pin carrying a loose Coupling and a Collar to serve as an easy-turn handle, although this, of course, is a non-essential refinement.

With the Machine completed, operation can begin and it should be stressed that the secret of successful heald-making lies in the wire used. We found that No. 24 s.w.g. steel or copper wire gave perfectly good results.

Cut an 11½" length of wire and form it into a loop by twisting the ends together. Extend the loop into a large sausage shape and mount in the machine by hooking the ends over Threaded Pins 10, with Long Threaded Pin 4 projecting through the centre of the loop. Then, turn the winding handle until the two Compression Springs are fully compressed — and you have one completed heald!

It will be found that the original twisted-together ends of the wire will project, but this should not effect the operation of the healds when mounted in the Loom.

PARTS REQUIRED:

2 - 8a	2 - 31	2 - 74
4 - 9d	21 - 37a	2 - 108
2 - 12b	19 - 37b	1 - 109
1 - 13	4 - 38	2 - 111c
2 - 16a	5 - 59	2 - 115
2 - 24	1 - 63	3 - 115a
3 - 26	2 - 72	2 - 120b

No. 24 s.w.g. Steel or Copper Wire

POWER LOOM

A Classic from the 'Fifties

THE FOLLOWING building instructions are intended for use in conjunction with the photographs of the Meccano Power Loom which appear on Pages 70 and 71 of the July, 1974 issue of Meccano Magazine Quarterly. The Loom, which is presented in the Magazine as Model No. 4 in our 'Past Masters' series, first appeared in the December, 1953 and January, 1954 issues of the "MM". It is therefore important to stress that the instructions here are themselves reprinted from the original Magazines, with only the photograph figure numbers being changed to conform to the MMQ layout and reference to the current E15R Motor being substituted for the original power unit which was a now-obsolete E20R Motor. We believe the instructions are correct in every main detail, but, as we did not write them, readers will understand if we disclaim responsibility for any errors, or differences in descriptive style which might exist! Now, read on..

CONSTRUCTION OF THE FRAME

The base of the frame (Fig.5) is built from four 12½" Angle Girders. Four 7½" Angle Girders 1 are bolted to the inside Angle Girders 2 and are held firm by two 5½" x 3½" Flat Plates 3, which support two 9½" Angle Girders 4 (see Figs. 1 and 5). Two 4½" x ½" Double Angle Strips 5 are fixed between the Flat Plates 3. Bolted to the inside of the Flat Plates 3 are four 3½" Angle Girders 6 (Figs 4 and 5), spaced from the Plates by three Washers on each Bolt. Two 9½" Angle Girders 7 (Fig.8), are secured to the base and connected to the top of the Plates 3 by 1½" x ½" Double Angle Strips. Two corner Gussets 8 and 8a and two 1½" Corner Brackets are bolted to the Girders 7 as shown in Figs. 1 and 8. To the Corner Gusset 8a two 1" x 1" Angle Brackets are fixed, and these, together with two Girder Brackets 9, form the bearings for the driving shaft 24 to the heald tappets. Two 7½" compound girders 10 (Fig.8), are bolted to the base and to the 9½" Angle Girders 4, and are braced to the base by 3½" strips. At the other end of the base two 7½" compound girders 11 are fixed. These support the *breast beam* which is a 5½" Angle Girder 12. To the girders 11 are also bolted two 4½" Strips 13 spaced from the girders by four

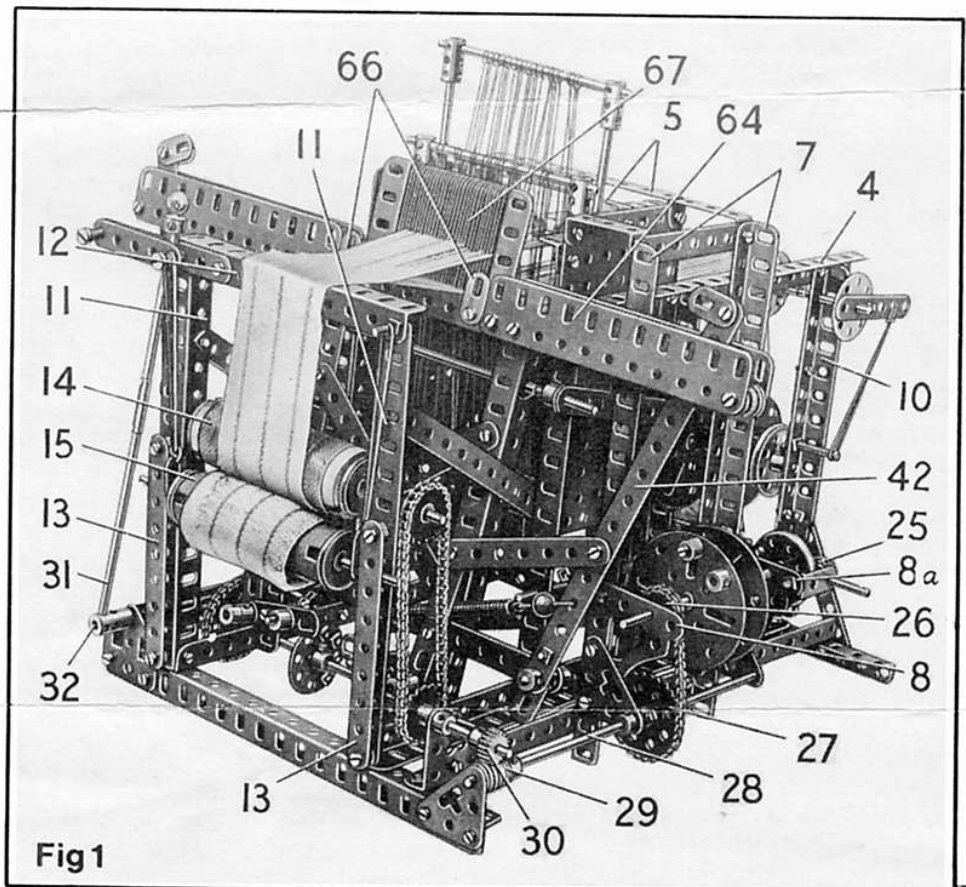

Fig 1
The above illustration is a reprint of one of eight highly-detailed photographs which appear in the July 1974 issue of the Meccano Magazine Quarterly.

Washers on each of the Bolts. A lock for the Motor starting handle is a 2½" Strip mounted on Pivot Bolts and held by Compression Springs against a 3½" Strip bolted to the side of the Girder 12 (Fig.1.). The sand roller 14 which is a Wood Roller with rough sand paper glued around is held between 1" Pulleys on a Rod mounted in the girders 11.

The take-up Roller 15 is mounted on a Rod between 1" Pulleys and the Rod slides between girders 11 and the Strips 13. This Roller is held against the sand roller 14 by the tension of two Driving Bands. These are attached to Fishplates slipped over the ends of the lower Roller Rod, and the Bands are anchored at their upper ends to the Pivot Bolt and ½" Bolt fixing the Girder 12 in position. The breast beam is braced by two 5½" Strips 16 placed as shown in Fig.2.

THE DRIVE

An E15R Electric Motor is bolted to one of the angle girders 10 (Fig.8) and is supported also by a 2½" Strip 62 (Fig.5) bolted to the base, and a 3½" Strip attached to a vertical 7½" Strip 63. A 2½" x ½" Double Angle Strip is bolted to the inner sideplate of the Motor and to one of the Girders 2. A ¾" Bolt is used to fasten 2½" Strip 62 and the 3½" Strip to the Motor, and this Bolt acts also as a stop to prevent the Motor starting lever from going into reverse (Fig.5). A ½" Pinion on the Motor shaft engages with a 57-tooth Gear, on the shaft of which another ½" Pinion 17 drives a 57-tooth Gear on Rod 19, which also carries a 1" Sprocket.

A Chain from this drives another 1" Sprocket 20 on Rod 18, which also carries a ½" Pinion that engages a 3½" Gear Wheel 21 on Rod 22 (Fig. 8). Rod 18 is supported in Strip 63 (Fig. 5), and one of the Flat Plates 3. Rod 22 (Fig. 8) has a 2" Sprocket 23 at its centre, and a 2½" Gear is fixed to the Rod at the opposite end to the Gear 21.

The 11½" Rod 24 carries at its centre a 2" Sprocket, which is conn-

ected by Chain to Sprocket 23, a ¾" Pinion 25 at one end and a ¾" Sprocket 37 (Fig.5) at the other end.

HEALD FRAME TAPPET CAMS.

The two cams that operate the heald frame tappets each consists of a Face Plate 56 (Fig.8), fitted with a Threaded Boss and a ½" Bolt carrying six Washers. These Face Plates are mounted as shown with the Threaded Bosses diametrically opposite to each other on a Rod supported in the Corner Gussets 8 and 8a, and the Rod carries also a 1½" Contrate that is driven by the Pinion 25. This Rod carries also a ¾" Sprocket 26 (Fig.1.), which drives a 1½" Sprocket 27 on Rod 28. Rod 28 is mounted in the Corner Brackets previously mentioned as bolted to the Angle Girders 7 and in another Corner Bracket fixed to the end of the base. This forms the drive to the sand roller, through a Worm 29 that engages a ½" Pinion 30. The Rod on which Pinion 30 is fixed is mounted in a 1½" Corner Bracket, and in a 1½" Strip bolted to one of the girders 11. A 1" Sprocket on this Rod is connected by Chain to a 1" Sprocket on the Rod of the sand Roller 14.

The Motor is started and stopped from a control handle 31, which is a Rod fixed in a Threaded Coupling 32. An 11½" Screwed Rod is locked by a nut in the Coupling, and at a point about one inch from the other end of the Screwed Rod a Threaded Crank is fixed to it with two Nuts. The end of the Screwed Rod is supported in a 1" x 1" Angle Bracket held by Bolt 33 (Fig.5) to the base. A ½" Bolt in the Motor starting lever engages with a 1" x ½" Angle Bracket bolted to the arm of the Threaded Crank.

THE PICKING CAMS

The shuttle is "thrown" to and fro along the shuttle race or guide of the slay 64 (Fig.1), by the action

of picking sticks 42, which in turn are actuated by cams. Each of these two cams consists of four Collars bolted in four adjacent holes of a Bush Wheel 34 (Fig.5), secured on a Rod 36. The entire slay assembly rocks to and fro on this Rod 36. A ¾" Sprocket 37 drives a 1½" Sprocket 35 and rotates the cams in an anti-clockwise direction. It is important to note that these cams also are set at 180° to each other, that is with the Collars in each cam diametrically opposite.

THE SLAY AND SHUTTLE RACE

The shuttle race is made in two sections. Each of these is built up by placing on a ¾" Bolt 38 (Fig.4) the following parts, in the order given starting from the head of the Bolt: a 5½" Flat Girder, a 9½" Strip, a Washer, a 5½" Strip, two Washers, a 5½" Strip, two Washers, a 5½" Strip, a 9½" Strip, a Washer and a second 5½" Flat Girder. The two sections thus assembled are then placed together so that the 9½" Strips of one section overlap the same strips of the other section by nine holes. The two sections are then connected together by the 1.1/8" Bolts 39 and 39a (Fig.4). The 5½" Strips of the sections are spaced apart on these Bolts by Washers, and in addition to the 5½" Strips the Bolts support three 4½" Strips 65 placed face to face at the exact centre of the shuttle race. Two fishplates 66 (Fig.1) are fixed to the front edge of the shuttle race at the inner ends of the Flat Girders.

The reed 67 (Fig.1) is built from 2½" Strips, which are spaced with Washers on two 3" Screwed Rods and edged at each side with a 2½" Angle Girder as shown. This unit is then bolted to the centre of the shuttle race. The Shuttle race is attached by Bolts 39 and 39a (Fig.4), to two 7½" Angle Girders, which are pivoted at their lower ends on the Rod 36 already mentioned. The Girders are braced by two crossed 5½" Strips 40 (Fig.2). Two 9½" Strips 41, placed face to face, and bolted centrally across the 9½" Angle Girders and a

Crank is bolted to each end of the Strips.

Each picking-stick 42 (Fig.2), is a 7½" Strip, and it has a Fishplate fixed to its upper end as shown and a Double Arm Crank to its lower end. The Double Arm Crank of each picking stick is held by a Collar on a 1½" Rod fixed in the Crank at the end of the Strips 41.

The picking sticks are operated by Bell Cranks 44, which are free to turn on 1" Rods fixed in Rod Sockets bolted to the lower ends of the 7½" Angle Girders that support the shuttle race. The Bell Cranks are held on the 1" Rods by Collars, and one arm of each is extended by a 3" Strip 47, and a Double Arm Crank 45 is bolted to the other arm. A 1½" Rod 46 is fixed in the Double Arm Crank and support the cam 34. The upper ends of Strips 47 are connected to the picking sticks 42 by 3½" Strips 48, pivoted on the locknuttled bolts. The force with which the picking sticks operate is controlled by Springs 49. Each is bolted to strips 41 and connected by a small Loaded Hook to the picking stick. The slay is linked by Strips lock-nuttled to Gears on Rod 22 and fitted with Cranks 50 fixed on Rod 51.

THE BEAMING FRAME

Assuming that the Loom has been built up to the stage so far described, the next operation is the construction of the Heald Frames. These are the frames that hold the Healds through which the warp threads are passed from the beam. They are actuated by the cams 56 and rise and fall to provide the "shed" through which the shuttle carrying the weft thread passes.

On a 4" Rod (bottom) and a 4½" Rod (top) 30 Healds should be placed, with a Coupling on each end of each Rod. The Couplings are joined together lengthwise by 5" Rods, and these must be passed through the top 3½" Angle Girders 6 before the Rods are fixed in the Couplings. The lower Couplings carry 3½" Rods to extend the 5" Rods lengthwise, and an End Bearing 52

(Fig.8), is secured to the bottom of one of the Rods. A 7½" Strip 53 is pivoted between the lugs of the End Bearing, and the Strip is *lock-nuttled* to a Fishplate 54 pivoted on Rod 55. The Fishplate is *lock-nuttled* in the 10th Hole of the Strip 53, counting from the end Bearing. Spring Clips are used to space the Fishplates and hold the Strips 53 in line with cams 56.

After being raised by the action of the cams, the Heald Frames are returned to their lowest positions by the tension of 2½" and 6" Driving Bands looped together and anchored on a Rod 57 (Fig.8), and the bottom of the Heald Frames. The Heald Frames should move very freely on depressing Strips 53.

THE WARP TENSION MECHANISM

A simple mechanism is provided to keep the warp threads at a suitable tension. This is shown clearly in Figs. 4 and 8. Two Bush Wheels are fixed to Rod 58, with a 3" Rod 59 mounted in holes in the Bush Wheels. A Bush Wheel extended with a 3" Strip is fixed to the end of Rod 58. A 6" Driving Band looped between the 3" Strip, and a 1.1/8" Bolt fixed to the frame imparts the required tension to the warp threads while the Heald Frames are moving up and down. A Cord, slightly tensioned with a Spring and passed over a 1½" Pulley 61, maintains tension on the warp beam.

THE SHUTTLE

Construction of the shuttle, which is shown in Fig.6, is quite simple. It consists of two 3½" Strips, two End Bearings and a 1½" Rod. The ends of the Strips are bent slightly to fit the lugs of the End Bearings. A 3/8" Bolt, which should for preference be filed slightly shorter, is passed through the end hole of one of the strips and then through the lugs of an end Bearing. A Washer is placed on the Bolt between the lugs of the Bearing, and the Bolt is then passed through the end hole of the other 3½" Strip. This process is rep-

eated at the other ends of the Strips.

A 1½" Rod that forms the spindle on which the weft thread is wound, is held loosely in the bosses at the End Bearings, and is retained in place by stops made by screwing the grub screws right down. *The grub screws must not grip the rod.* The sides of the shuttle must be parallel and the completed shuttle must be an easy sliding fit in the shuttle race. When it is in position in the race the picking sticks must strike the shuttle nose centrally.

Carefully wind some "weft" thread on the shuttle spindle, keeping it in the centre portion of the Rod. Do not try to put too much on at one filling, and make sure it will run off perfectly freely, otherwise the shuttle may "stick" between the warp threads. The thread is then brought out from the shuttle as shown.

BEAMING FRAME

Fig. 3 shows a simple Beaming Frame suitable for preparing the beam of warp threads ready for insertion in the loom. The base of the frame is a 5½" x 3½" Flat Plate, fitted at each side with a 5½" Angle Girder 1 that supports a 5½" x 2½" Flat Plate. A Rod 2 carries the beam 3 on which the threads are wound.

A handle 4 is fitted to one end of the Rod, 2 and the other end carries a Ratchet Wheel 5. A Pawl 6 on a Pivot Bolt engages the teeth of the Ratchet Wheel. The Pawl is weighted by Washers on a 3/8" Bolt screwed into its Boss.

The reed or frame 7 consists of 31 2½" Strips spaced apart by Washers on two Screwed Rods, and is supported in the 5½" x 2½" Flat Plates by Collars on two Rods 8.

Now knock two nails into a wall, a few yards apart, and then wind around them 30 turns of thread. These are now taken off the nails, carefully, and cut at one end. You will then have 60 separate lengths of thread. The threads are now drawn through the reed, two threads between each pair of strips, and with one knot are secured to the centre of the beam axle, Holding the threads tightly in

the left hand, wind them on to the beam; the reed will space the threads evenly between the Face Plates. A little practice will soon produce a neat beam.

DRAWING THE WARP

Put the prepared beam in the loom. Take the first thread, pull it through the *first* heald on the *front* frame, then the second thread and pull it through the *first* heald on the *back* frame. These two threads are drawn through the *first* division or dent in the reed. Continue in this way using each dent until all the threads are drawn through. Lightly brush and pass them around the upper roller and secure them to the take-up roller by means of the Rod placed in its groove.

TIMING THE LOOM

The mechanism must be set so that, when the slay is at back centre, one heald frame is in its highest position and will stay up until the shuttle has passed through the warp threads. The picking stick motion should then come into action just

before the slay reaches back dead-centre, and should shoot the shuttle across to reach the other end just as the slay leaves back dead centre. A little time spent in careful adjustment will soon give the desired position for smooth running.

COMPONENT CHANGE

This, then, completes the building instructions as originally printed (we're back to "us" on the MMQ now, by the way!), but as mentioned in the July Magazine, an important component change has taken place since the Loom was first designed; The Meccano Heald, Part No. 101, has been discontinued. The Meccano engineer is never beaten, though, and a specially-designed machine for making your own healds is featured on Page 72 of the July MMQ. Please note, however, that in the following Parts List for the Loom - copied from the original article - we have left the old Part Number in place for identification purposes.

Talking of the Parts List, we should finally mention that this applies only to the Parts required for the Loom, itself. The Beaming Frame is not included. For this, we must rep-

eat the statement printed in the original feature: "The parts used in the Beaming Frame should be clear from the illustration."

PARTS LIST

6- 1a	6-15	154- 38	4-103
5- 1b	5-15a	3- 43	2-106
14- 2	2-15b	2- 48	3-108
5- 2a	6-16	5- 48a	4-109
9- 3	1-16a	2- 48c	3-111
3- 4	4-16b	2- 52a	6-111a
33- 5	5-18a	3- 57c	24-111c
1- 6a	2-18b	24- 59	3-111d
4- 8	2-21	4- 62	2-120b
6- 8a	4-22	1- 62a	1-126a
4- 8b	1-23a	4- 62b	2-128
9- 9	5-24	8- 63	4-133
2- 9a	1-25	1- 63c	1-136a
6- 9b	4-26	2- 64	1-144
2- 9d	2-27a	1- 78	2-147b
10-10	1-27b	2- 80c	2-161
1-12	1-27c	2- 94	4-166
3-12a	1-28	2- 95	2-179
1-12b	1-32	2- 95a	2-186
1-13	12-35	4- 96	5-186a
3-13a	172-37a	2- 96a	1-213
4-14	120-37b	60-101	
E15R Electric Motor			