

## MODEL OF THE MONTH

# Twin Cylinder Marine Engine

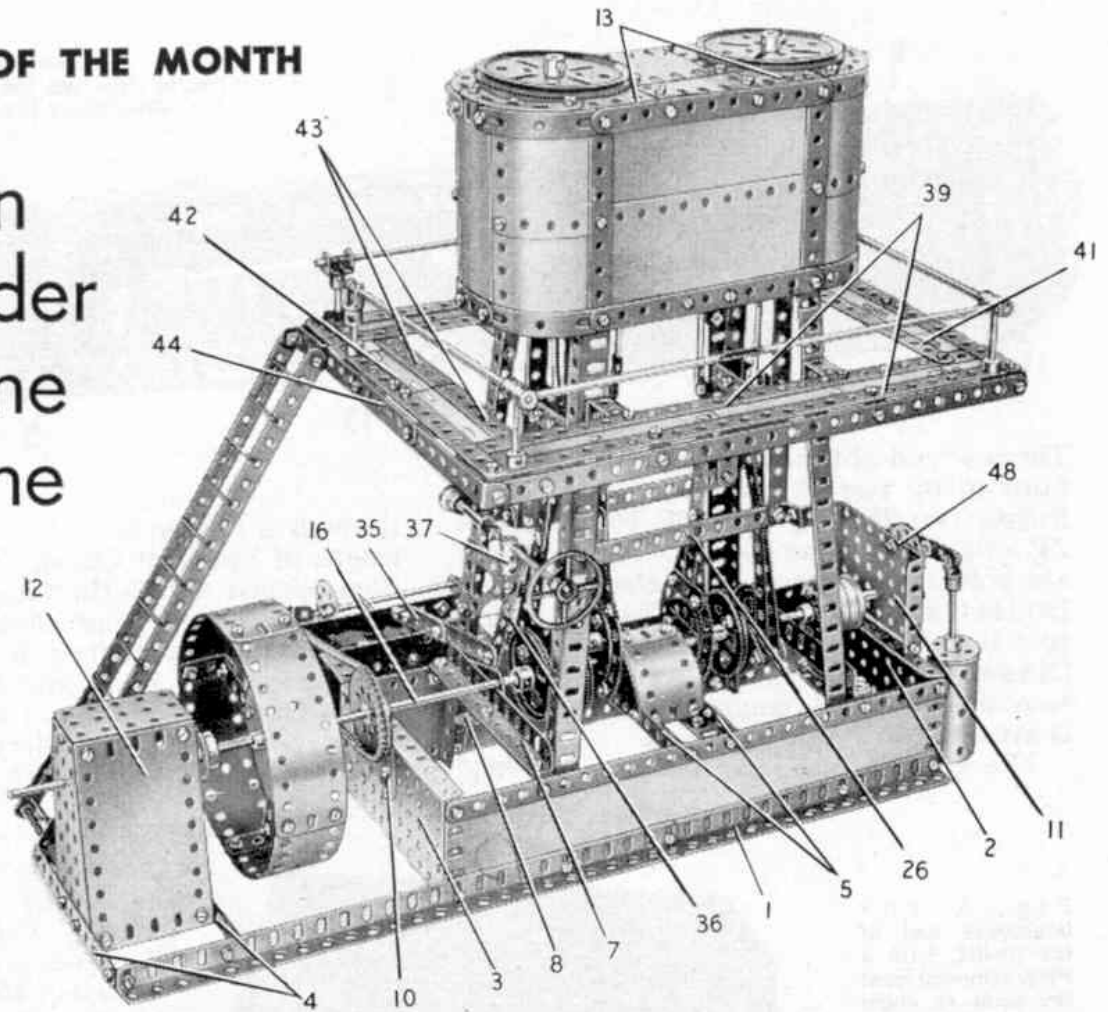

Fig. 1:  
This splendid  
model can be  
built with  
parts in a  
No. 8 Outfit.

Fig. 2.  
A detail view of  
part of the model,  
showing the  
arrangement of the  
crossheads and the  
valve eccentrics.

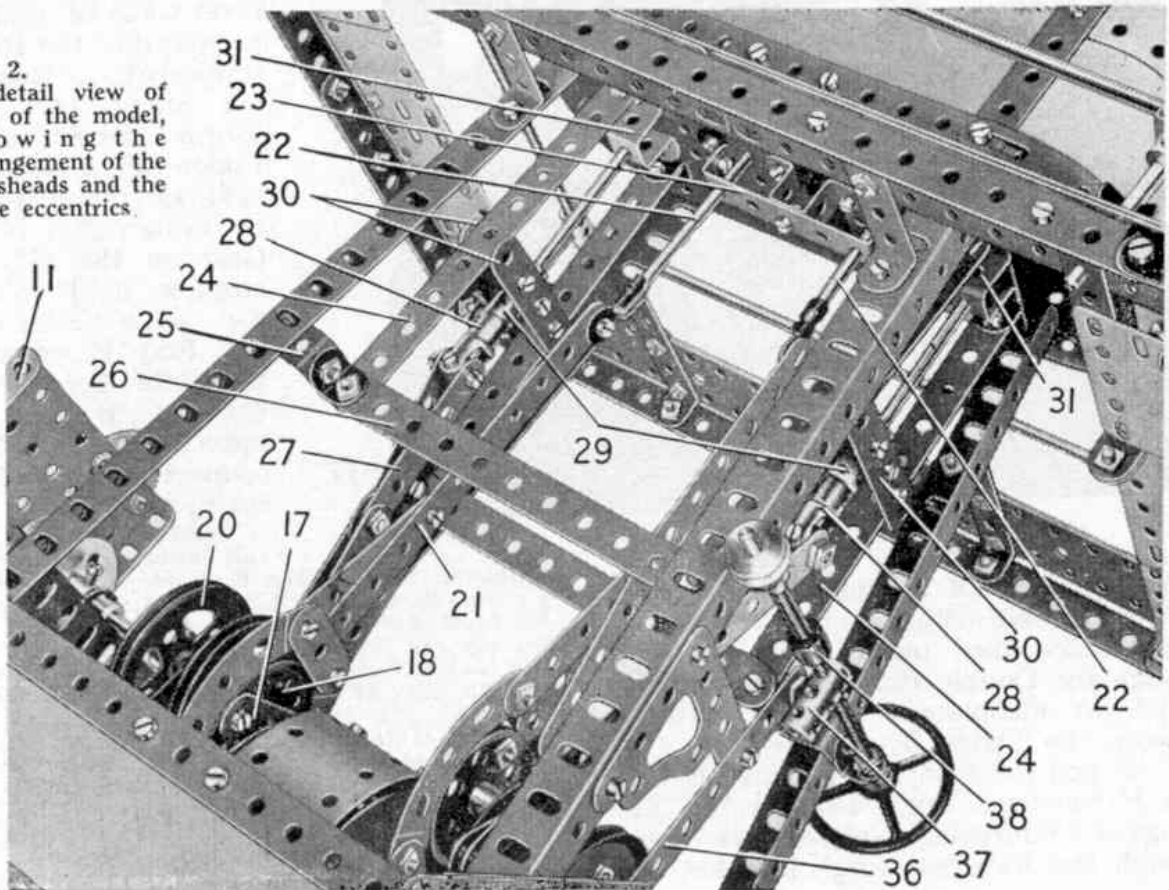
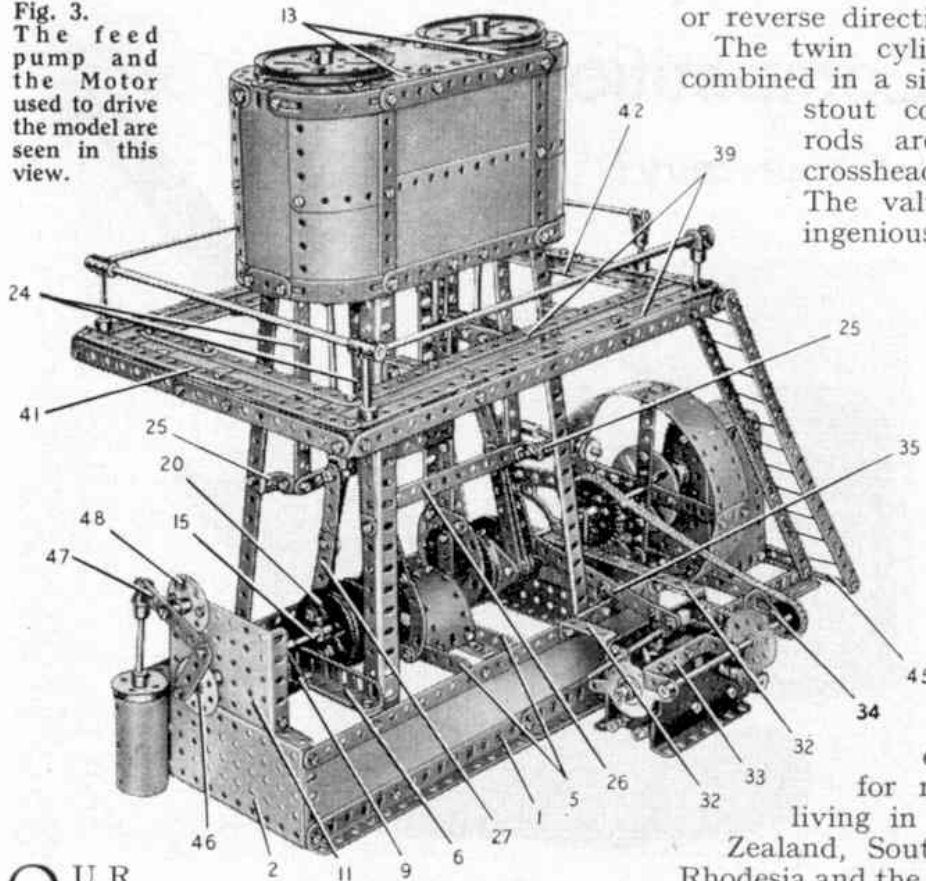

Fig. 3.  
The feed pump and the Motor used to drive the model are seen in this view.



or reverse directions.

The twin cylinders of the model are combined in a single casing supported by stout columns, and the piston rods are correctly fitted with crossheads guided by slide bars. The valve rods are worked by ingeniously built-up eccentrics, and at one end of the crankshaft a crank-operated feed pump is fitted. An inspection platform surrounds the cylinder block.

Meccano enthusiasts in this country who wish to build the Twin Cylinder Marine Engine can obtain full constructional details and a list of the parts required by writing to the Editor,

enclosing a 2d. stamp for return postage. Readers living in Canada, Australia, New Zealand, South Africa, Ceylon, Italy, Rhodesia and the United States of America, can obtain their copies of the *current* Model of the Month Instructions by writing to the main Meccano agents in those countries, enclosing suitable stamps to cover return postage.

**O**UR model

this month is one that will appeal to the many model-builders who delight in the construction of model steam engines and other forms of power units. The Twin Cylinder Marine Engine illustrated in these pages is designed for construction with parts in a No. 8 Outfit, and it is shown fitted with an E20R(S) Electric Motor that drives the crankshaft realistically. An attractive feature is that the reversing switch of the Motor is connected to a screw-operated mechanism controlled by a hand wheel. Turning this wheel enables the model to be set working in either forward

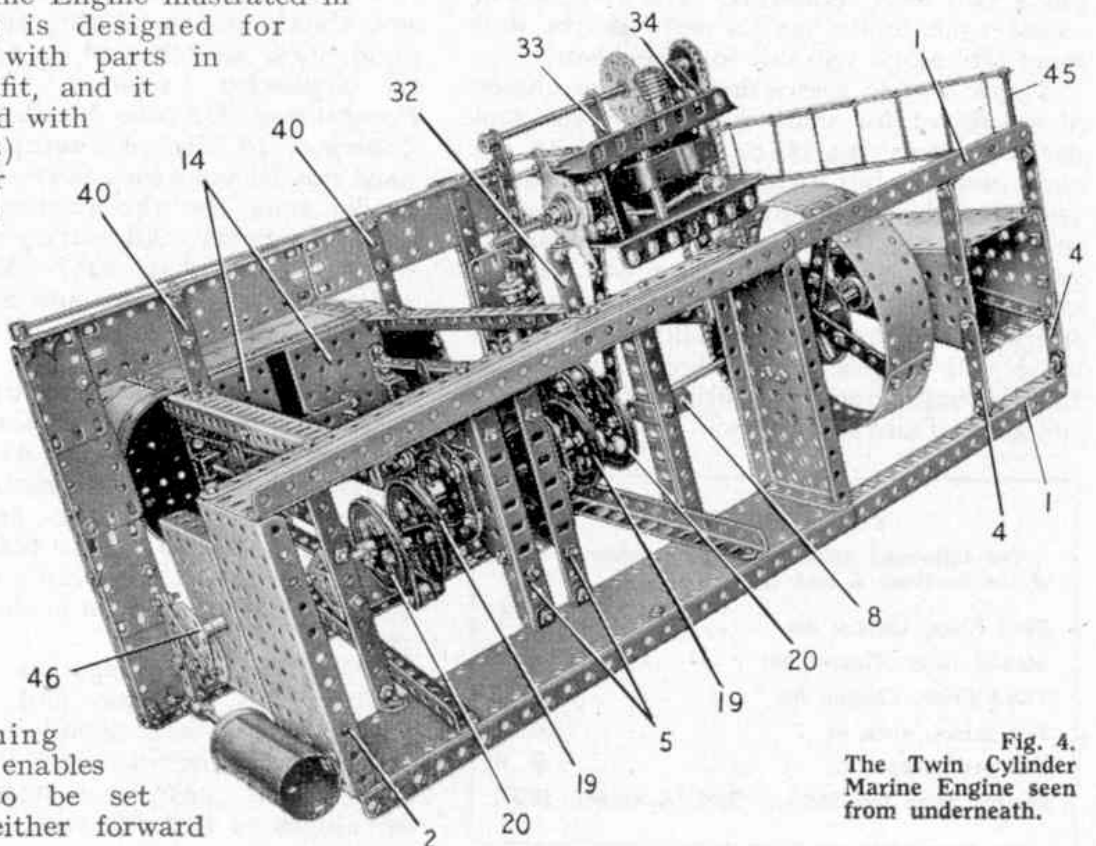

Fig. 4.  
The Twin Cylinder Marine Engine seen from underneath.

TWIN CYLINDER MARINE ENGINEIllustrated in the November 1957 issue of the Meccano MagazineConstruction of the Engine Bed

Each side of the engine bed consists of a  $12\frac{1}{2}$ " x  $2\frac{1}{2}$ " Strip Plate, edged along the top by a  $12\frac{1}{2}$ " Strip and at the bottom by a built-up girder 1 made from two  $12\frac{1}{2}$ " Angle Girders overlapped 11 holes. The sides are connected by  $5\frac{1}{2}$ " x  $2\frac{1}{2}$ " Flanged Plates 2 and 3 and by a  $5\frac{1}{2}$ " and two  $2\frac{1}{2}$ " Strips 4 attached to Angle Brackets.

Two  $5\frac{1}{2}$ " Angle Girders 5 are fixed to Angle Brackets bolted to the sides, and to each Angle Girder is bolted a Semi-Circular Plate. Two  $2\frac{1}{2}$ " x  $1\frac{1}{2}$ " Flexible Plates are curved and are attached to the Girders 5 by Angle Brackets, between the Semi-Circular Plates.

Two  $5\frac{1}{2}$ " Angle Girders 6 and 7 are bolted to  $5\frac{1}{2}$ " x  $1\frac{1}{2}$ " Double Angle Strips fixed between the sides of the engine bed. A 1" x 1" Angle Bracket 8 is attached to the Girders 7, and a Trunnion 9 is fixed to the Girder 6. A  $2\frac{1}{2}$ " Strip 10 is bolted to the Flanged Plate 3 and a  $3\frac{1}{2}$ " x  $2\frac{1}{2}$ " Flanged Plate 11 is attached to the Plate 2 by Angle Brackets.

The thrust block 12 consists of two Flanged Sector Plates joined by  $4\frac{1}{2}$ " x  $2\frac{1}{2}$ " Flexible Plates and capped by a  $2\frac{1}{2}$ " x  $1\frac{1}{2}$ " Flanged Plate.

The Supporting Columns and the Cylinder Block

Each column is a  $12\frac{1}{2}$ " Angle Girder fixed to one of the girders 1 and bolted to the cylinder block. The sides of the block are each made from two  $5\frac{1}{2}$ " x  $2\frac{1}{2}$ " Flexible Plates edged by  $5\frac{1}{2}$ " and  $4\frac{1}{2}$ " Strips. Each rounded end consists of four 1 11/16" radius Curved Plates and a curved  $4\frac{1}{2}$ " x  $2\frac{1}{2}$ " Flexible Plate, edged as shown in Fig. 3 by four Formed Slotted Strips and a  $1\frac{1}{2}$ " Strip.

Two  $3\frac{1}{2}$ " x  $2\frac{1}{2}$ " Flanged Plates 13 are bolted between the sides at the top, and to them are fixed two  $2\frac{1}{2}$ " x  $2\frac{1}{2}$ " Flexible Plates, four  $2\frac{1}{2}$ " Stepped Curved Strips, and two 3" Pulleys mounted on  $\frac{1}{2}$ " Bolts. Two further  $3\frac{1}{2}$ " x  $2\frac{1}{2}$ " Flanged Plates 14 (Fig. 4) are bolted between the lower edges of the sides.

The Crankshaft, Piston and Valve Assemblies

The crankshaft is in three sections, a 4" Rod 15 mounted in the Flanged Plate 11 and the Trunnion 9, a second 4" Rod mounted in the Semi-Circular Plates bolted to the Girders 5, and an  $11\frac{1}{2}$ " Rod 16 supported in the thrust block 12, the Strip 10 and the Angle Bracket 8.

A Crank 17 is bolted across the face of a  $1\frac{1}{2}$ " Pulley 18, and is fixed to one end of the centre 4" Rod. A similar assembly is fixed at the other end of the Rod, and two 2" Pulleys 19 are also fixed to the Rod. A 2" Pulley 20 is fastened to the inner end of each of the Rods 15 and 16, and a Flat Trunnion is bolted to the face of each of the Pulleys 19 and 20 so that the hole in the pointed end of the Flat Trunnion projects outside the rim of the Pulley.

The strap of each valve eccentric consists of two  $2\frac{1}{2}$ " Stepped Curved Strips connected by two  $1\frac{1}{2}$ " Strips, and arranged so that the assembly rotates freely in the groove of one of the Pulleys 18. A  $5\frac{1}{2}$ " Strip 21 is bolted to the ends of two  $2\frac{1}{2}$ " Strips fixed to the Stepped Curved Strips as shown in Fig. 2. The upper end of Strip 21 is lock-nutted to a Rod and Strip Connector on a Rod 22. The Rod is free to slide in one of the Flanged

Plates 14 and in a  $2\frac{1}{2}$ " x  $\frac{1}{2}$ " Double Angle Strip 23, (Fig. 2), which is attached to the Flanged Plates 14 by Angle Brackets and a Double Bent Strip.

The piston rod slide bars are  $5\frac{1}{2}$ " Strips 24 attached to the Flanged Plates 14 by Angle Brackets and connected by Angle Brackets at their lower ends to  $\frac{1}{2}$ " Reversed Angle Brackets 25. The lower ends of the Strips 24 on each side are connected by a  $5\frac{1}{2}$ " Strip 26.

The piston connecting rods 27 are each made from two  $2\frac{1}{2}$ " and two  $3\frac{1}{2}$ " Strips spaced apart at their lower ends by a Collar and connected at the centre by a bolt. A  $\frac{3}{4}$ " Bolt is passed through one of the Flat Trunnions bolted to the 2" Pulleys and is fitted with two Washers and passed through the lower end of the connecting rod. A Washer is placed on the Bolt, which is then fixed by two nuts in the second Flat Trunnion of each pair.

The upper end of each connecting rod pivots on a  $\frac{1}{2}$ " Bolt lock-nutted in a Swivel Bearing 28. This is fixed on a Rod passed through a Coupling 29, to which two  $2\frac{1}{2}$ " Strips 30 are fixed by bolts. A bolt is passed through each Strip, is fitted with a nut and is screwed tightly into the Coupling 29. The nut is then tightened against the Strip to fix it at right angles to the Coupling. Each pair of Strips 30 is fitted with two Double Brackets and these slide freely between the Strips 24 forming the slide bars.

The piston rods are supported in the Flanged Plates 14 and in Double Bent Strips 31 bolted to the Flanged Plates.

### The Driving Mechanism

An E20R Electric Motor is attached to one side of the engine bed by two  $1\frac{1}{2}$ " x  $\frac{1}{2}$ " Double Angle Strips 32. A Worm on the Motor shaft drives a 57-tooth Gear on a 5" Rod supported in a  $2\frac{1}{2}$ " x 1" Double Angle Strip 33 and in a Trunnion 34. A 1" Sprocket on the 5" Rod is connected by Chain to a 2" Sprocket on Rod 16.

A Screwed Rod is fixed to the Motor switch lever by two nuts, and is similarly attached to a 1" Triangular Plate bolted to a built-up strip 35. This strip consists of a  $4\frac{1}{2}$ " Strip extended one hole by a  $2\frac{1}{2}$ " Strip, and it is lock-nutted to a  $3\frac{1}{2}$ " Strip 36. Strip 36 pivots on a bolt lock-nutted to a Corner Gusset (Fig. 2), and is connected to a Coupling 37 by a bolt locked in the Coupling by a nut. The Coupling is threaded on a Screwed Rod joined to a  $1\frac{1}{2}$ " Rod by a Rod Connector and a Screwed Rod Adaptor 38. The Screwed Rod and the  $1\frac{1}{2}$ " Rod are mounted in Angle Brackets bolted to the supporting columns, and are held in position by lock-nuts on the Screwed Rod and a  $\frac{1}{2}$ " fixed Pulley on the  $1\frac{1}{2}$ " Rod. By turning a Steering Wheel on the Screwed Rod the Motor switch is operated through the connecting links.

### The Flywheel

The flywheel rim consists of four  $5\frac{1}{2}$ " x  $1\frac{1}{2}$ " Flexible Plates bolted together so that they overlap by two holes at each of their ends. The rim is attached by 1" x 1" Angle Brackets to  $5\frac{1}{2}$ " Strips bolted across a Face Plate.

### The Inspection Platform

Each side of the platform consists of two  $5\frac{1}{2}$ " x  $1\frac{1}{2}$ " Flexible Plates bolted to the  $12\frac{1}{2}$ " Strips 39 and edged by a  $12\frac{1}{2}$ " Strip bolted to the lugs of  $2\frac{1}{2}$ " x  $\frac{1}{2}$ " Double Angle Strips 40 and to Angle Brackets. The platform end 41 is made from four  $2\frac{1}{2}$ " x  $1\frac{1}{2}$ " Flexible Plates bolted on the outside to two  $5\frac{1}{2}$ " Strips overlapped four holes, and on the inside to a  $5\frac{1}{2}$ " and a  $2\frac{1}{2}$ " Strip overlapped two holes. This end is edged by two  $5\frac{1}{2}$ " Strips attached to Angle Brackets.

The platform end 42 is made from two  $2\frac{1}{2}$ " x  $1\frac{1}{2}$ " Flexible Plates

bolted on the outside to a  $5\frac{1}{2}$ " and a  $4\frac{1}{2}$ " Strip overlapped two holes, and edged on the inside by two  $4\frac{1}{2}$ " x  $\frac{1}{2}$ " Double Angle Strips 43. The edge of this end is completed by two  $3\frac{1}{2}$ " x  $\frac{1}{2}$ " Double Angle Strips joined at the centre by a 3" Strip 44.

The handrail supports are 2" Rods held in the platform by Collars and Spring Clips. The handrails are Rods supported in Couplings and Fork Pieces as shown. One of the side handrails consists of a  $6\frac{1}{2}$ " and a  $4\frac{1}{2}$ " Rod joined by a Rod Connector.

The completed platform is attached to the cylinder supporting columns by means of the Double Angle Strips 40.

The ladder is made from two  $12\frac{1}{2}$ " Strips attached to the platform by an Angle Bracket and a Fishplate, and to one of the girders 1 by means of nuts on a Screwed Rod 45. The rungs are represented by Cord.

The Feed Pump

A Bush Wheel 46 is fixed next to a Collar on Rod 15, and a 2" Strip is lock-nutted to the Bush Wheel and to a 3" Strip 47. Strip 47 is pivoted on a Pivot Bolt and is spaced from a Bush Wheel 48 by a Collar. The Pivot Bolt is held in the boss of the Bush Wheel 48. The Strip 47 is lock-nutted to an End Bearing on a  $3\frac{1}{2}$ " Rod, which slides freely in a  $1\frac{1}{8}$ " Flanged Wheel pressed into one end of a Cylinder. The Cylinder is attached to the Flanged Plate 2 by  $\frac{3}{8}$ " Bolts, but is spaced from the Flanged Plate by two Washers on each Bolt.

PARTS REQUIRED

10 of No. 1	1 of No. 18a	2 of No. 48d	4 of No. 125
21 " " 2	2 " " 19b	1 " " 51	2 " " 126
6 " " 2a	3 " " 20	2 " " 52	4 " " 126a
5 " " 3	4 " " 20a	5 " " 53	1 " " 147b
2 " " 4	1 " " 20b	2 " " 54	2 " " 165
17 " " 5	2 " " 21	10 " " 59	1 " " 166
1 " " 6	1 " " 23a	2 " " 62	1 " " 173a
6 " " 6a	2 " " 24	6 " " 63	1 " " 185
8 " " 8	1 " " 27a	1 " " 77	8 " " 188
4 " " 9	1 " " 32	1 " " 80a	8 " " 189
1 " " 10	5 " " 35	2 " " 80c	2 " " 190
4 " " 11	289 " " 37a	8 " " 90a	4 " " 191
33 " " 12	257 " " 37b	1 " " 94	4 " " 192
5 " " 12a	23 " " 38	1 " " 95	2 " " 197
2 " " 13	2 " " 38d	1 " " 96a	8 " " 200
1 " " 13a	1 " " 40	1 " " 108	2 " " 212
3 " " 14	3 " " 45	1 " " 109	2 " " 213
4 " " 15	1 " " 46	2 " " 111	2 " " 214
1 " " 15a	2 " " 48	5 " " 111a	8 " " 215
2 " " 15b	5 " " 48a	7 " " 111c	1 " " 216
1 " " 16	2 " " 48b	1 " " 116	1 E20R(S) Electric Motor.
5 " " 17	2 " " 48c	1 " " 116a	