

**MODEL OF
THE MONTH:**

**A
Fascinating
Textile
Machine**

THE various kinds of machines used in the textile industry make really attractive subjects for experienced model-builders, as the many intricate movements provide fascinating scope for skilful design. Among these machines the loom is undoubtedly the best known to Meccano model-builders, and the one that is reproduced most often. But there are many other equally interesting machines used to prepare the threads and yarn for weaving. One of these is the thread twisting and knopping machine on which the September Model of the Month is based.

The main

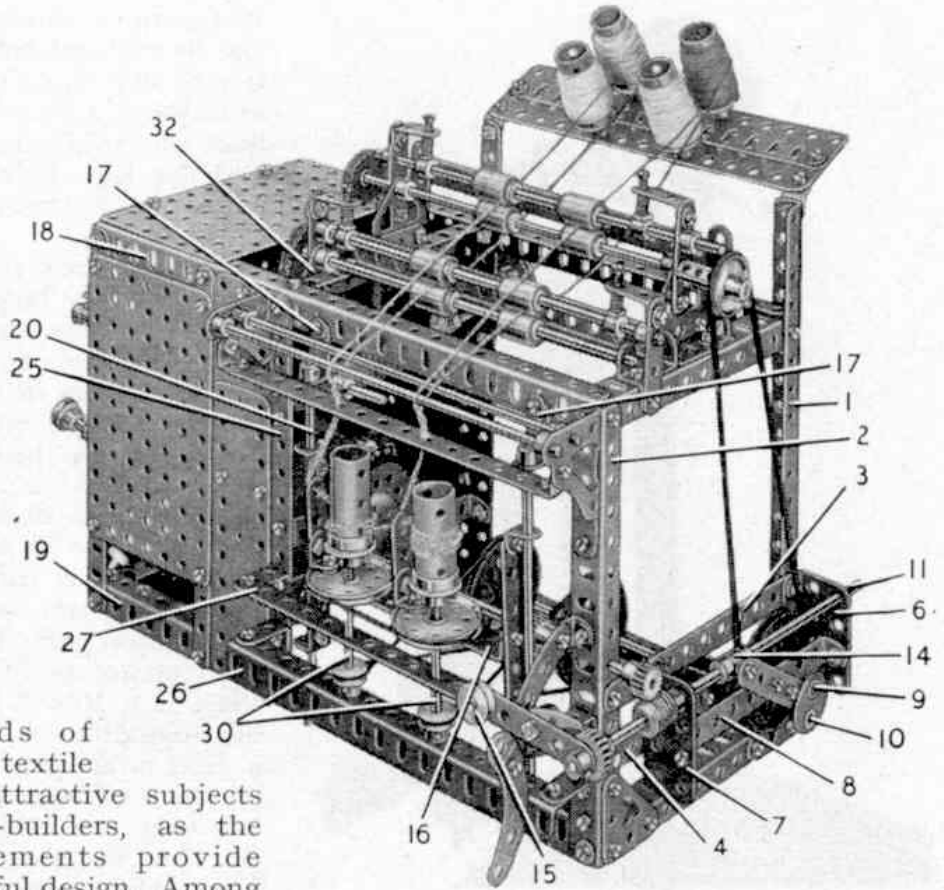

Fig. 1. A thread twisting and knopping machine for preparing special type threads for use in textile weaving. Ingenious mechanisms make it an attractive model to watch in motion.

purpose of this machine is to twist together two single-ply threads to form one thicker and stronger thread, but at the same time it can be used to produce a variety of threads of various kinds. If the two threads to be twisted are of different colours, one light and one dark, the final double-ply thread can be produced in an amazing variety of patterns. For example, one of the colours can be made to show predominately for a given length of thread, then automatically the machine will revert to an even twist of both colours.

Another important function of this machine is the production of "knop" threads, that is, threads in which at intervals small bunches of one coloured thread are twisted round the other thread, to form a small bead or knop. These knop threads can be made up into a variety of materials, and as the knops are usually in bright colours the resulting cloth is colourful and attractive.

The real machines may have as many as 200 spindles each, and they run at very high speeds. The Meccano model has two spindles, and it has been necessary to depart slightly from the design of the

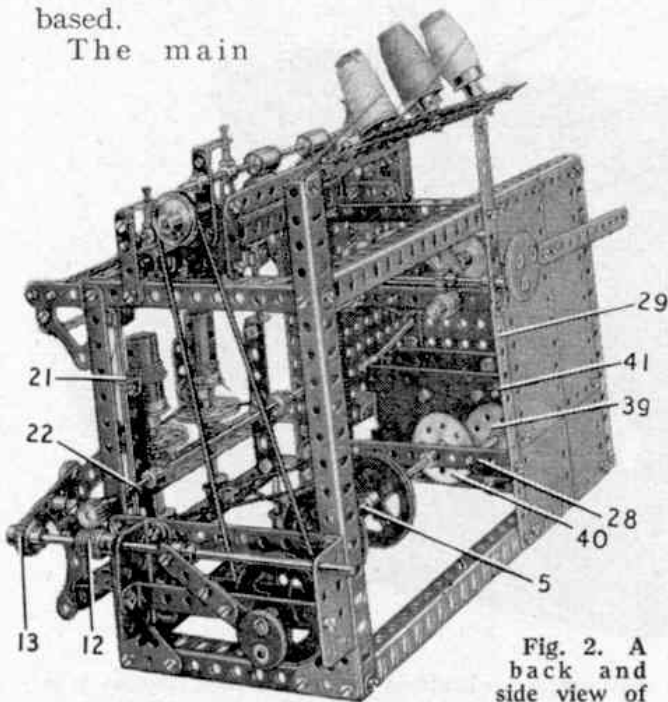
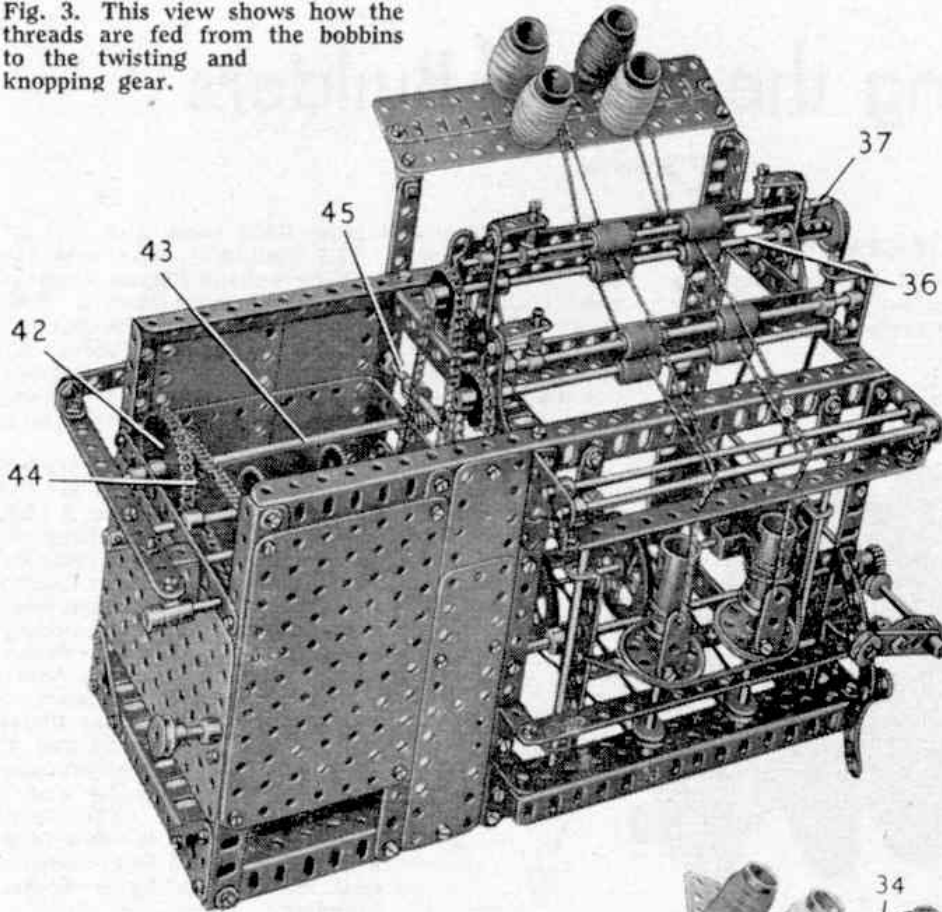

Fig. 2. A back and side view of the thread twisting and knopping machine.

Fig. 3. This view shows how the threads are fed from the bobbins to the twisting and knopping gear.



Magazines later than readers in this country.

We are still receiving requests for copies of the Instructions for models that appeared in previous issues, but unfortunately all supplies of these have now been distributed, with the exception of the Instructions for the Motor Chassis that appeared in last month's *M.M.* We expected an exceptionally large demand for details of this model and accordingly we prepared an extra quantity. A few copies are still available.

actual machine in order to make the construction as simple as possible. Nevertheless it works in much the same way as the real machine and it is fascinating to watch in action.

The model is operated by an E20R(S) Electric Motor and is provided with an automatic gear-box that allows drives at various speeds and of intermittent duration to be selected. The variations in the designs of the finished threads are made by adjusting the ratios and the nature of the drive by means of this gear-box.

Full constructional details of this fine model, and a list of the parts required to build it, can be obtained by writing to the Editor, enclosing a 2d. stamp for postage. Application should be made as early as possible; otherwise you may find that all supplies have been distributed. The demand for the Model of the Month instructions has increased steadily, and although we do our best to ensure adequate supplies, we cannot promise that we will be able to meet requests received a long time after publication. We have made special arrangements to reserve copies for Overseas model-builders who receive their

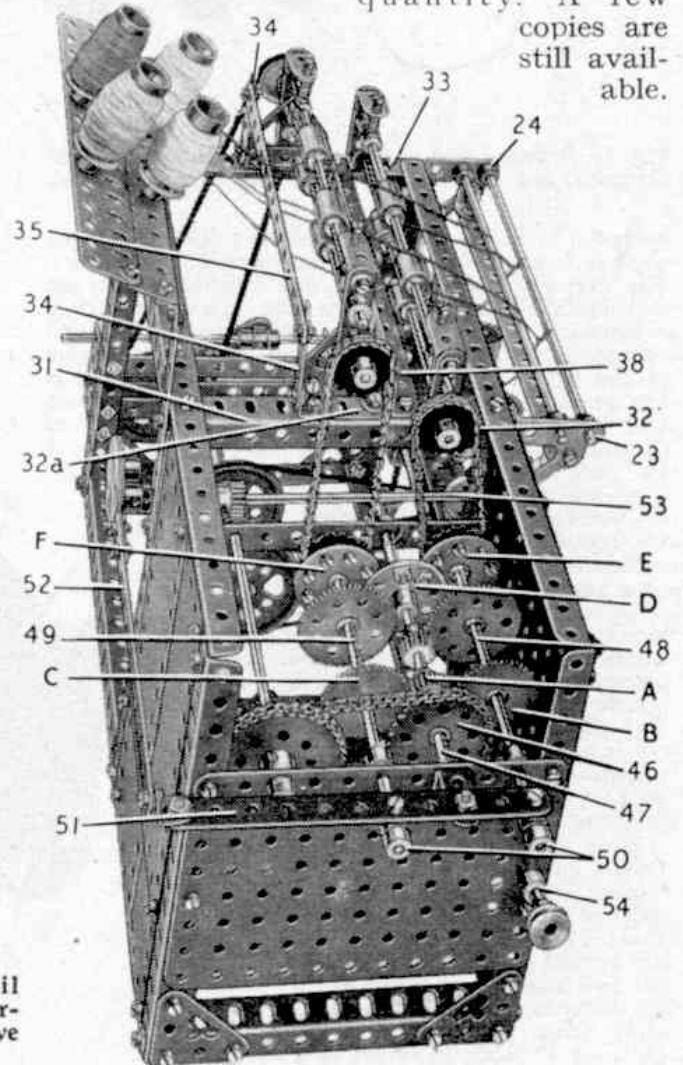

Fig. 4. Detail view of the gear-box and the drive to the rollers.

MODEL OF THE MONTHTHREAD TWISTING AND KNOPPING MACHINE

Illustrated in the September 1956 issue of the "Meccano Magazine."

An E20R(S) Electric Motor is required to drive this model

Start building the model by making the main framework, using four $12\frac{1}{2}$ " , three $7\frac{1}{2}$ " , three $5\frac{1}{2}$ " and a $9\frac{1}{2}$ " Angle Girder, and one $5\frac{1}{2}$ " Strip. The $9\frac{1}{2}$ " Angle Girder is indicated at 1 and one of the $7\frac{1}{2}$ " Angle Girders is marked 2. Each lower corner of the framework is braced by a $1\frac{1}{2}$ " Corner Bracket. Two $5\frac{1}{2}$ " Strips 3 and 4 are fixed to the Girders 1 and 2 and a Double Bent Strip is bolted to the Strip 4 to form a bearing for an 8" Rod 5. Two Girder Brackets 6 and 7 are fastened to the Strips 3 and 4 and are connected by a $4\frac{1}{2}$ " x $\frac{1}{2}$ " Double Angle Strip.

A $1\frac{1}{2}$ " Rod 9 is mounted in the Strip 4 and the Double Angle Strip and carries a 2" Pulley and a Single Throw Eccentric 10. An 8" Rod 11 supported in Girder Brackets 6 and 7 is fitted with a Worm 12, a Ratchet Wheel 13 and a Collar 14. Collar 14 is loose on the Rod but is located between two fixed Collars, and it is connected to the Eccentric by a 2" Strip.

A $2\frac{1}{2}$ " Strip is pivoted at one end of Rod 11 between the Ratchet 13 and a Collar, and a Pawl mounted on a Pivot Bolt fixed in the Strip engages the teeth of the Ratchet. A $\frac{1}{2}$ " Pulley 15 bolted to the free end of the Strip forms a weight that keeps the Strip in contact with a $2\frac{1}{2}$ " Curved Strip attached to Girder 2 by an Angle Bracket. As Rod 11 is slid to and fro by the Eccentric the $2\frac{1}{2}$ " Strip is raised by the Curved Strip and the Pawl rotates the Ratchet and the Rod 11. A $2\frac{1}{2}$ " Stepped Curved Strip bolted to the lower end of the Curved Strip acts as a stop that limits the movement of the $2\frac{1}{2}$ " Strip and its Pawl.

Fix two 1 " x $\frac{1}{2}$ " Angle Brackets 17 to the $12\frac{1}{2}$ " Angle Girder 18 and bolt two 1 " Corner Brackets to the horizontal flange of the Angle Girder 19. The Angle Brackets and the Corner Brackets form bearings for Rods 20 and 21, which are held in place by Collars. Two $3\frac{1}{2}$ " Rack Strips, each fitted with two Angle Brackets, are connected by a $4\frac{1}{2}$ " x $\frac{1}{2}$ " Double Angle Strip 16, and the Angle Brackets are arranged to slide freely on Rods 20 and 21. An 8" Rod 22 is mounted in Girder 2 and in an Angle Bracket bolted to a $7\frac{1}{2}$ " Strip 25. The Rod carries three $\frac{1}{2}$ " Pinions, two of which engage the Rack Strips while the third meshes with the Worm 12.

Two Flanged Brackets 23 and 24 are bolted to the Girder 2 and the Strip 25, and are connected by a $7\frac{1}{2}$ " Strip supported by Angle Brackets. Two 8" Rods are held in position in the Flanged Brackets by Collars. A $7\frac{1}{2}$ " Angle Girder 26 and a $7\frac{1}{2}$ " Strip 27 are fixed to 1 " x 1 " Angle Brackets bolted to Girder 2 and the Strip 25.

A $5\frac{1}{2}$ " x $\frac{1}{2}$ " Double Angle Strip 28 is fixed between the Strip 25 and a $9\frac{1}{2}$ " Strip 29 and an 8" Rod 5 is mounted in the Double Angle Strip and in the Strip 4. Rod 5 carries a 60-tooth Gear 40 and two 2" Pulleys. The spindles 30 are 3" Rods fitted with $\frac{1}{2}$ " Pulleys, and each Rod is supported in the Girder 26 and the Strip 27 and is held in place by a Collar fitted with a $7/64$ " Grub Screw. The $\frac{1}{2}$ " Pulleys and the 2" Pulleys on Rod 5 are connected by Driving Bands.

Two Fishplates fixed to the Double Angle Strip 16 are arranged with their elongated holes over the spindles 30. A $1\frac{1}{2}$ " Pulley, fitted with an Angle Bracket that supports a vertical $1\frac{1}{2}$ " Strip, is placed loosely on each of the spindles so that it rests on the Fishplate, and a $\frac{3}{4}$ " Flanged Wheel that supports a Sleeve Piece is fixed on the spindle. A short length of elastic or Spring Cord is attached at each end to the Double Angle Strip 16 and is placed round the grooves

of the $1\frac{1}{2}$ " Pulleys to provide a light braking effect.

A 1" Corner Bracket 32, extended upward by a 2" Slotted Strip, and a $1\frac{1}{2}$ " Angle Girder 32a, are fixed to a $5\frac{1}{2}$ " Angle Girder 31. A Flat Trunnion is bolted to Girder 32a and is extended upward by a 2" Slotted Strip, and a similar assembly is attached to Angle Girder 33, together with a 2" Slotted Strip in line with the Corner Bracket 32. Two 2" Slotted Strips 34 are attached to the Girders 31 and 33 by Angle Brackets and these support a $7\frac{1}{2}$ " Strip 35.

An 8" Rod 36 is placed in two of the bearing assemblies described above and is held in place by Collars. This Rod carries two Couplings covered with short pieces of $\frac{3}{8}$ " diameter rubber tubing. At one end the Rod 36 carries a 1" Sprocket, while at the other end a Coupling supports a 1" Rod on which a 1" Pulley is fixed. This Pulley is connected to the 2" Pulley on Rod 9 by a Driving Band. An 8" Rod 37 is mounted in the slotted holes in the bearings, and is pressed downward by two Compression Springs, each of which is passed over a $\frac{3}{4}$ " Bolt. The Bolt is supported in a $1" \times \frac{1}{2}"$ Angle Bracket bolted to one of the 2" Slotted Strips, and is fixed by a nut in a Collar on Rod 37, leaving the Collar loose on the Rod. Rod 37 carries two Couplings covered with rubber tubing, and is held in place by Collars. This arrangement provides rollers for two of the threads used in the machine, and a similar set of rollers for the remaining two threads is mounted in the front pair of Slotted Strips.

Two $7\frac{1}{2}$ " Flat Girders are bolted together and are connected by Obtuse Angle Brackets to the Strip 29 and the Girder 1. Four $1\frac{1}{8}"$ Bolts fixed by nuts in the Flat Girders form spindles for the bobbins, which are Sleeve Pieces held in $\frac{3}{4}"$ Flanged Wheels.

A $5\frac{1}{2}" \times 2\frac{1}{2}"$ Flat Plate is fixed between the lower $12\frac{1}{2}"$ Angle Girders of the framework two holes from one end, and an E2OR(S) Electric Motor is bolted to the Flat Plate. A $7/16"$ Pinion on the Motor armature shaft drives a 60-tooth Gear 39 on a $4\frac{1}{2}"$ Rod, which is mounted in the Motor side-plates. This Rod carries a $\frac{3}{4}"$ Pinion, and a $7/16"$ Pinion that engages the 60-tooth Gear 40. The $\frac{3}{4}"$ Pinion drives a 50-tooth Gear on a Rod 41, which is mounted in the upper corner holes of the Motor side-plates and carries a $\frac{3}{4}"$ Sprocket. This Sprocket is connected by Chain to a 2" Sprocket 42 fixed on a Rod 43. Rod 43 is mounted in $5\frac{1}{2}"$ Strips fixed across the framework and it is fitted with a 1" Sprocket 44 and a Worm 45. Sprocket 44 drives a $1\frac{1}{2}"$ Sprocket 46 on a Rod 47, which carries also a $\frac{1}{2}"$ and a $\frac{3}{4}"$ Pinion and a Bush Wheel D fitted with two Set Screws placed in adjacent holes and held by nuts.

Two $6\frac{1}{2}"$ Rods 48 and 49 are each fitted with a 57-tooth Gear, a 50-tooth Gear, a 1" Sprocket, and a Bush Wheel with eight Set Screws held in its holes by nuts. On the outer end of each Rod a Collar is held loosely between two fixed Collars, and bolts passed through holes in a $5\frac{1}{2}"$ Strip 51 are fixed in the loose Collars by nuts. Strip 51 pivots on a Bolt lock-nutted in a $1" \times 1"$ Angle Bracket bolted to the framework, and a $\frac{1}{2}" \times \frac{1}{2}"$ Angle Bracket lock-nutted to the end of Strip 51 is lock-nutted also to a $5\frac{1}{2}"$ Strip 52. Strip 52 is bolted to a Triple Throw Eccentric, which is fixed in its $\frac{3}{4}"$ throw position on a $6\frac{1}{2}"$ Rod 53. The Rod 53 is mounted across the framework and a $\frac{1}{2}"$ Pinion on it is driven by Worm 45. The 1" Sprockets on Rods 48 and 49 are connected by Chain to the Sprockets of the Roller assembly.

The Motor switch arm is extended by a $3\frac{1}{2}"$ Rod fitted with a Collar that is screwed on to a Bolt passed through the upper arm of the switch. Flexible and Flat Plates of various sizes are used to enclose the Motor and the gear-box.

To set up the model wind fine darning wool (preferably in two colours) on each of the four bobbins. Each length of wool from the two rear bobbins is passed under Strip 35, through a hole in a $7\frac{1}{2}"$ Angle

Girder 38, between the front rollers and over the front one of the two Rods held in the Flanged Brackets 23 and 24.

The wool from the two front bobbins is threaded through holes in the Strip 35, through the rear rollers and over the rear one of the two Rods in the Flanged Brackets. The front and rear threads are now connected in pairs, passed through one of the 1 1/2" Strips attached to the 1 1/2" Pulleys, and fastened to the appropriate Sleeve Piece.

The following hints on setting the gear-box will give some idea of the types of threads it is possible to make by altering the gearing of the machine.

No. 1



Light and dark twist, light "knop", light and dark twist, dark knop. With the Triple Throw Eccentric in operation, set 3/4" Pinion A so that it engages alternately with the Gear Wheels B and C. The Gears should remain in mesh as long as possible. The term "Knop" refers to a thicker section in a length of thread made by twisting a small bunch of one thread round the other.

No. 2

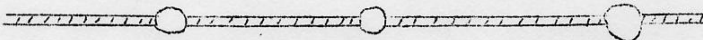

Light and dark twist, single colour "knop". Triple Throw Eccentric working. Set Gears so that Pinion A is in constant mesh with Gear B and meshes intermittently with Gear C.

No. 3



Alternate solid colours. Disconnect Triple Throw Eccentric. The Set Screws in Bush Wheel D alternately drive the Bush Wheels E and F.

No. 4



Light and dark twist, one colour. Disconnect Triple Throw Eccentric. Bush Wheel D drives Bush Wheel E and Pinion A engages Gear C.

No. 5

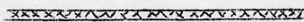

All twist. Pinion A engages both the Gears B and C. For a finer twist use the 1/2" Pinions and the 57-tooth Gears.

- Parts Required:- 6 of No. 1b; 6 of No. 2; 1 of No. 2a; 1 of No. 5; 1 of No. 6; 2 of No. 6a; 4 of No. 8; 1 of No. 8a; 5 of No. 8b; 4 of No. 9; 2 of No. 9f; 2 of No. 10; 13 of No. 12; 5 of No. 12a; 6 of No. 12b; 2 of No. 12c; 9 of No. 13a; 7 of No. 14; 1 of No. 15a; 4 of No. 16; 1 of No. 18a; 1 of No. 18b; 3 of No. 20a; 6 of No. 20b; 2 of No. 21; 1 of No. 22; 1 of No. 23; 3 of No. 23a; 3 of No. 24; 2 of No. 25; 5 of No. 26; 2 of No. 26c; 3 of No. 27; 2 of No. 27a; 2 of No. 27d; 2 of No. 32; 188 of No. 37a; 156 of No. 37b; 38 of No. 38; 1 of No. 45; 2 of No. 48c; 2 of No. 48d; 3 of No. 52a; 6 of No. 55a; 46 of No. 59; 9 of No. 63; 18 of No. 69; 24 of No. 69c; 1 of No. 70; 1 of No. 90; 1 of No. 90a; 1 of No. 94; 1 of No. 95; 1 of No. 95a; 5 of No. 96; 1 of No. 96a; 2 of No. 103k; 2 of No. 110; 4 of No. 111; 1 of No. 111a; 3 of No. 111c; 4 of No. 111d; 2 of No. 114; 4 of No. 120b; 1 of No. 125; 2 of No. 126a; 1 of No. 130; 1 of No. 130a; 4 of No. 133; 3 of No. 133a; 1 of No. 136; 1 of No. 139; 1 of No. 139a; 1 of No. 147; 1 of No. 148; 2 of No. 161; 6 of No. 163; 2 of No. 186b; 1 of No. 186d; 2 of No. 189; 4 of No. 192;