

Fig. 1. The Hand Loom in its completed state set up for weaving.

Build this Fine Hand Loom!

ONE of the earliest and greatest triumphs of Meccano was the construction, with standard parts, of looms with which textile materials could actually be made, working on the same principles as the looms of our great cotton and woollen mills. Countless model-builders have built looms for themselves since that first achievement, and throughout the years one builder after another has developed improvements and additions, including the installation of motors, that have increased the scope and variety of this particular piece of textile machinery in Meccano, and others have been added. Actually in comparatively recent months two special textile machines have been included in the *Model of the Month* series, and the great demand for the building instructions concerning them that followed their

appearance was a testimony to the popularity of models of this type.

With this in mind, a similar subject has been taken for the January 1959 Model of the Month, but on this occasion it is a Hand Loom, with which it is possible to weave bands of cloth in a variety of patterns, and it is a model that will test the skill of the builder in both construction and operation. It is therefore particularly suitable for advanced model-builders. The Loom is seen complete in Fig. 1.

The weaving material used in this loom is 2-ply or thin 3-ply wool, which is readily obtainable. The model is entirely hand operated, and although weaving with it is rather a slow process, good work can be produced with careful operation and the model demonstrates the principles of simple cloth weaving excellently.

The Hand Loom has four heald frames, each of which is controlled by a separate lever. Variations in the weaving pattern are produced by operating these levers in different combinations and sequences.

As usual, full constructional details for building the model are available. To get them, just write to the Editor,

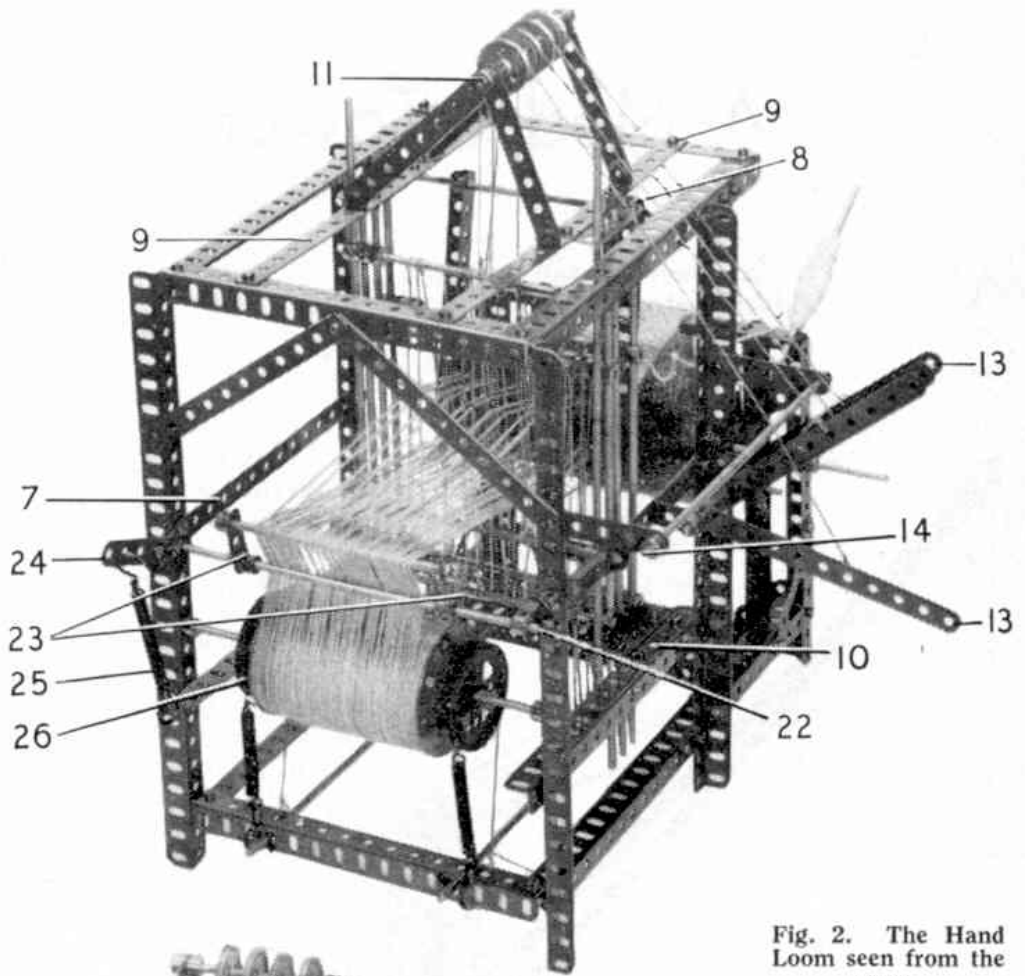
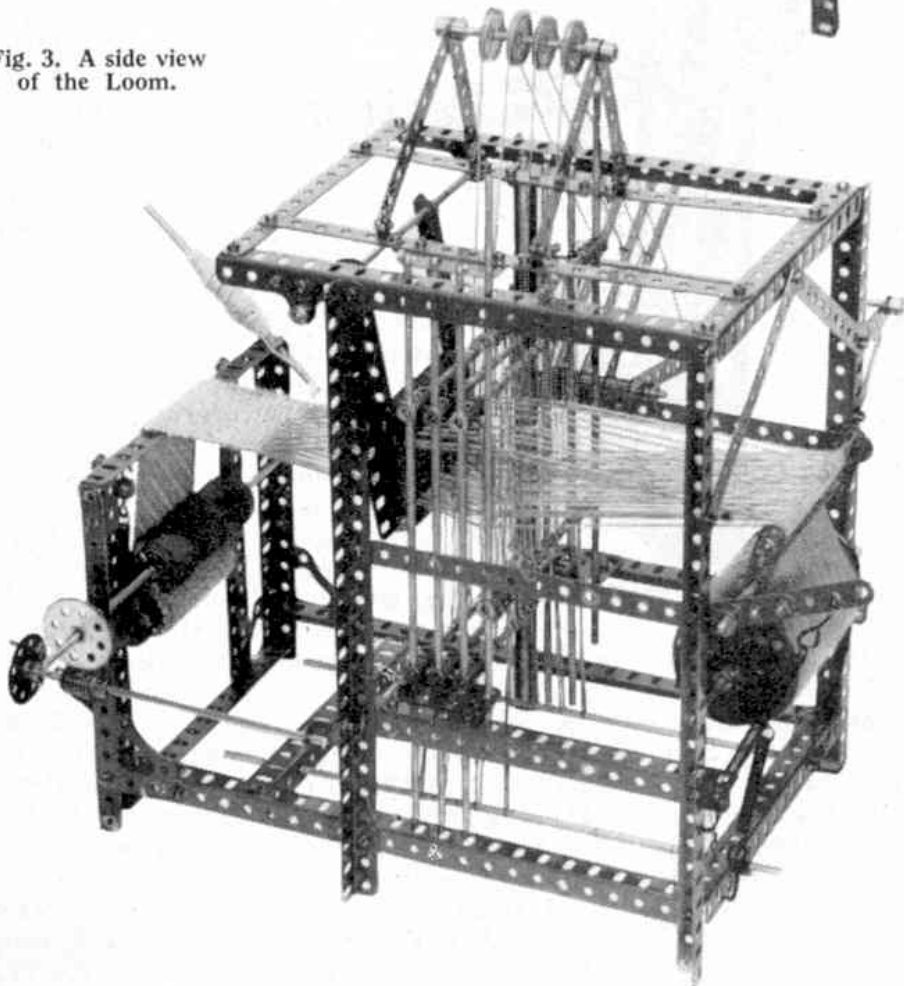

Fig. 2. The Hand Loom seen from the rear.

Fig. 3. A side view of the Loom.



Meccano Magazine, Binns Road, Liverpool 13, enclosing a 2d. stamp. Readers living in Canada, Australia, New Zealand, South Africa, Ceylon, Italy, Rhodesia and the United States of America should write to our main agents in those countries for their copies of the current Model of the Month instructions, also, of course, enclosing suitable stamps for postage. Write at once and make sure of your copies.

HAND LOOM.

Illustrated in the January 1959 issue of the Meccano Magazine.

Framework.

Bolt two 12½" Angle Girders 1 and 2 to a 12½" Angle Girder 3, and a 7½" Angle Girder 4, supported with a Corner Gusset. A 7½" Angle Girder 5, a 9½" Angle Girder 6, and a 7½" Strip 7 are bolted to the Angle Girders 1 and 2. Build another similar side and connect them together with five 7½" Angle Girders and a 7½" Strip. Attach a 2" Flat Girder to the 9½" Strips 9 and also fix another 2" Flat Girder, extended by a 2" Flat Girder 10, to the Angle Girder 5.

Heald Frames.

Each Heald frame is built from two 11½" Rods, two 5" Rods and four Couplings, and each holds ten healds. Place these in the Flat Girders 8 and 10, and adjust the Flat Girders to allow free up and down movement of the frames. To the Strips 9 two 4½" and two 3½" Strips are attached by means of Angle Brackets. Four loose 1" Pulleys are placed on a Rod 11 in the top end holes of the Strips. Bolt a 2½" x 1" Double Angle Strip 12 to one of the 7½" Strips 7 and place in it a 3½" Rod with four 5½" Strips two of which ^{are} shown marked 13. Collars should be used to space them apart. To each heald frame, at a point near the centre of the top rod, tie a cord and connect it to one of the Strips 13. Note: The heald frame must be in the bottom position and the Strips 13 raised against the stop rod 14, which is mounted in Corner Gussets. Next, strong elastic bands are attached to each heald frame and the 11½" Rods 21 as shown in the illustrations.

The Reed.

On two 3½" Screwed Rods place a 2½" Strip and a Washer alternately until 40 spaces or "dents" are made. Then secure a 5½" Angle Girder to each end of the Screwed Rods with Nuts. The Reed is suspended from the Rod 15, which is journaled in 1" Corner Brackets attached to the Angle Girder 6.

The Set-up Motion.

A Wood Roller, covered with sand paper, is secured to Rod 16 with a 57-tooth Gear Wheel 17 fixed to its end. The Gear engages with a Worm on a 6½" Rod 18, the Rod being mounted in a 1½" Corner Bracket and a ½" Reversed Angle Bracket bolted to the frame Girders as shown. Two 7½" Strips 19, placed face to face but spaced apart with four Washers, are bolted to the 7½" Angle Girders 20 in the positions shown. The gap between the pairs of 7½" Strips provides a slide for the axle of a Wood Roller, which is fixed on a 6½" Rod the ends of which project between Strips Springs attached to Loaded Hooks hooked on to the Girder 20 and also attached at their lower ends to the 6½" Rod, serve to hold the two Wood Rollers in contact.

Tension Motion.

An 8" Rod 22 fitted with two Cranks 23 and a Crank extended by a 2½" Strip 24, is placed in the end hole of Strips 7. Cranks 23 support a 4" Rod which is held in them by Collars. A Spring 25, hooked to the 2½" Strip and the Angle Girder applies the necessary tension to the warp threads.

The Warp Beam.

Four 3½" x ½" Double Angle Strips are bolted between two Face Plates, and the latter are fixed on an 8" Rod, together with two 2" Pulley Wheels 26. Cords passed around the Pulleys and held taut by Springs, keep the warp threads tight.

How to prepare the Warp Beam.

A suitable material to use for the warp threads is 2 or 3 ply wool. To prepare the threads ready for the beam, place two 6" nails which we will name A and B, about 3 yards apart, with two 6" nails C and D, placed between them 3 inches apart and about 18 inches from the outer nail A. Now fasten the wool to nail A, pass over nail C, and under nail D, around outer nail B, coming back over nail D, and under nail C, then around nail A. Repeat this sequence until 40 threads have been dealt with. Cut the threads at nail A. Using the Loom Reed, place the first thread in the first dent, the second thread in the second dent and so on, until all the threads are put through the Reed. The threads are tied together in one large dog knot. This knot is placed in the centre of the beam, between two of the Double Angle Strips, and the beam axle placed through the centre of the threads. With the Loom Reed hold in front of the beam, the threads will fan out to the width of the Face Plates, as the threads are tightly wound around the beam, after removing the nails C and D. The nails C and D are used only to keep the threads in the correct order, until they have been placed through the Reed. With all the warp wound on the beam, the threads are now cut off the nail B. The beam can now be placed in the loom, with the Reed removed.

Drawing the threads through the Healds.

Having placed the beam in position in the Loom, with the cords tensioned around the 2" Pulleys on the beam shaft, pull about 18" of the warp off the beam. Take the first thread and pass it through the 1st heald on the 1st frame. Then take the second thread and pass it through the 1st heald on the 2nd frame. Continue as follows:-

3rd Thread through 1st Heald on the 3rd frame.

4th " " " " " " 4th "

5th " " 2nd " " " 2nd "

6th Thread through 2nd Heald on the 1st frame.

7th " " " " " " 4th "

8th " " " " " " 3rd "

Repeat this sequence till all 40 threads are drawn through the healds. Now the 1st thread is put through the 1st dent in the reed, the 2nd in the 2nd dent and so on. Now brush all the threads up evenly and pass them around the Wood Roller wrapped with sandpaper, and fix them in the Wood Roller with a 3/2" Rod in the groove.

To Weave.

First wind a few yards of wool on to a 3/2" Rod to form the weft thread now choose one of the Design Schemes listed later in these instructions and depress the appropriate levers (13). Now pass the Rod carrying the weft thread between the warp threads. Release the levers, and draw the reed forward. Now push the reed back and depress the next set of levers as indicated in the Design Scheme. Pass the weft between the warp threads again and bring the reed forward to press the weft against the preceding one. Continue in this way, depressing the appropriate levers and when an inch of cloth has been woven, the Hand Wheel 18 can be turned to take up that amount on the Roller .

Design Schemes suitable for the Four Heald Frame Loom.

No. 1 Design.

- (1) Depress the 1st and 4th Lever and take the weft thread across.
- (2) " " 1st " 2nd " " " " " " " "
- (3) " " 2nd " 3rd " " " " " " " "
- (4) " " 3rd " 4th " " " " " " " "

No. 2 Design.

- (1) Depress the 1st and 3rd Lever.
- (2) " " 1st " 2nd "
- (3) " " 2nd " 4th "
- (4) " " 2nd " 3rd "
- (5) " " 1st " 3rd "
- (6) " " 3rd " 4th "
- (7) " " 2nd " 4th "
- (8) " " 1st " 4th "

No. 3 Design.

- (1) Depress the 1st and 3rd Lever.
- (2) " " 1st " 2nd "
- (3) " " 2nd " 3rd "
- (4) " " 3rd " 4th "
- (5) " " 2nd " 4th "
- (6) " " 1st " 2nd "
- (7) " " 1st " 4th "
- (8) " " 3rd " 4th "

No. 4 Design.

(1)	Depress the 1st and 4th Lever.
(2)	" " 1st " 2nd "
(3)	" " 2nd " 3rd "
(4)	" " 3rd " 4th "
(5)	" " 1st " 2nd "
(6)	" " 1st " 4th "
(7)	" " 3rd " 4th "
(8)	" " 2nd " 3rd "

No. 5 Design.

(1)	Depress the 2nd and 3rd Lever.
(2)	" " 1st " 3rd "
(3)	" " 1st " 4th "
(4)	" " 2nd " 4th "

It must be understood that the numbers 1 to 4, or 1 to 8, in any one design are to be repeated until the required amount of cloth has been woven.

Parts required to build the Four Heald Frame Loom.

2	of No. 1a	3	of No. 62
7	" " 1b	16	" " 63
6	" " 2	2	" " 80c
2	" " 2a	40	" " 101
2	" " 3	6	" " 103g
40	" " 5	2	" " 106
6	" " 8	6	" " 108
2	" " 8a	2	" " 109
9	" " 8b	34	" " 111a
2	" " 9	1	" " 115
4	" " 12	1	" " 125
11	" " 13	1	" " 133
4	" " 13a	2	" " 133a
2	" " 14	88	Elastic Bands
10	" " 15		

NOTE! Those model builders with not so many parts can use only two heald frames, working each one up and down alternately.