

Look - No Hands!

# DIGITAL CLOCK

Up - to - the - minute  
model by 'Spanner'

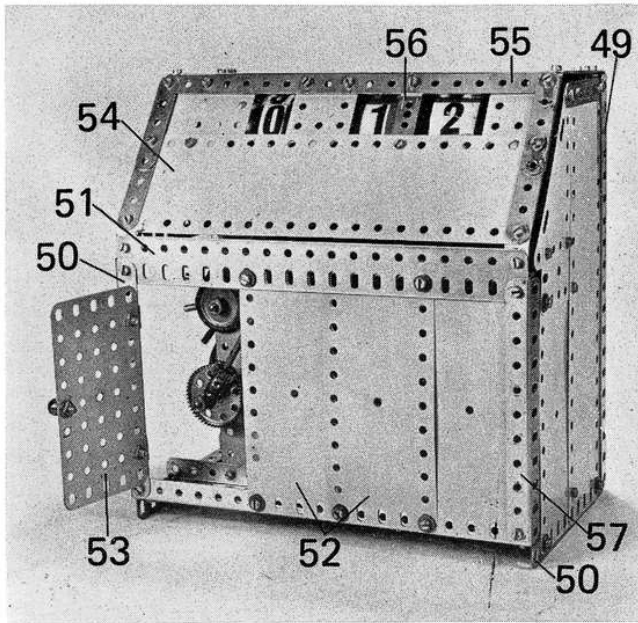

ONE OF the most impressive models we have featured in MMQ since its launch last year was Bert Love's Grandfather Clock, featured in the October 1973 issue. Built out of the entire contents of a No. 10 Set, the model was a working tribute, not only to the skill of its designer, but also to the tremendous capabilities of Meccano as a constructional medium.

It occurs to us, however, that, because a grandfather clock is a traditional instrument with its origins in clock-making history, the uninitiated observer might think that Meccano, itself, was good only for historic subjects. If this should happen, then the Digital Clock featured here will dispel all such incorrect illusions! Digital Clocks are very much a part of ultra-modern life - as a glance in any clock-seller's window will show - therefore this model again proves the 'forever-modern' nature of Meccano.

## CONSTRUCTION

Leaving the outer casing until later, a framework for the main clock mechanism is built up from a 5½" x 2½" Flanged Plate, to each side flange of which two 5½" x 3½" Flat Plates 1 are bolted to form a 6½" x 5½" compound flat plate. Note that the Bolts fixing the "front" plate to the Flanged Plate also hold a 9½" Angle Girder 2 in place, while the "back" plate fixing Bolts help to hold two 2½" Angle Girders 3 in position. Bolted to each upper corner of each plate is a 3" Angle Girder 4 projecting a distance of three holes horizontally beyond the plate. The outer ends of each pair

of Girders 4 are connected together by a 5½" Angle Girder, to the vertical flange of which a Corner Gusset 5 is tightly fixed in the position shown. Plates 1 are further connected by three 2½" x ½" Double Angle Strips, one bolted through the top row, centre holes of the plates and the other two through the second row down, second and fourth holes in from the right when looking at the front plate. Note that the inner of these latter two Double Angle Strips (numbered 6 in the illustration) will later serve as one of the bearings for one of the operating Rods. Two 3" Strips 7, one on top of the other for increased strength, are bolted to front plate 1, in the position shown, to project four holes above the plate, while a 2" Strip 8 is bolted in a corresponding position to back plate 1, this Strip projecting two holes above the plate. A Crank is fixed to the back of Strips 7, its boss coinciding with the upper holes in the Strips.

## SYNCHRONOUS MOTOR

Dealing, now, with the motor which drives the clock, this is a synchronous unit built up from standard and electrical parts. Four Electrical Cylindrical Coils 9 are each fixed to a 1½" Angle Girder, the securing Bolts passing through the round holes in the Girder. A Core is carried in each Coil, being held in place by a Bolt screwed through the centre round hole in each Angle Girder and into the threaded centre of the Core. Using the slotted holes of the Girders, the Coils are then tightly fixed to back plate 1 in the positions shown, but note that each

Angle Girder is spaced from the plate by four Washers on the shank of each securing ½" Bolt.

Freely revolving between the electro-magnets formed by the Coils-with-Core, is an 8-pole armature 10, built up from two 8-hole Bush Wheels, to each of which eight Rod and Strip Connectors are bolted, the shanks of the Rod and Strip Connectors radiating outwards uniformly. The armature is mounted on a 4" Rod journalled in the centre holes of plates 1 and carrying at its other end a ½" Pinion.

It is as well to wire up the motor at this stage and ensure that it operates correctly. Looking at the motor as it appears in the appropriate photograph, one power source terminal is connected to the "S" terminal of the lower Coil and the "E" terminal of the left-hand Coil. The other power source terminal is connected to the "E" terminal of the upper Coil and the "S" terminal of the right-hand Coil. The "E" terminal of the lower Coil is connected to the "S" terminal of the upper Coil, while the "S" terminal of the left-hand Coil is connected to the "E" terminal of the right-hand Coil.

The motor requires an input of 15 volts AC and, to set it operating, the armature should be spun anticlockwise at 750 r.p.m. This speed is "synchronous" with Alternating Current and, when it is reached, the armature should continue spinning unaided. Needless to say, the armature must be extremely free-running as, indeed, should be all the Rods and gear trains of the Clock. With this point in mind, it is advisable to take

special care in selecting the Rods and Gears, etc. for the remainder of the Clock, ensuring that all the Rods are perfectly straight and that the Gears run quite true.

### CLOCK MECHANISMS

Dealing next with the clock drive mechanisms, it is as well to follow things through in their natural operating sequence. In mesh with the Pinion on the front end of the armature shaft is a 57-teeth Gear Wheel 11 on a  $3\frac{1}{2}$ " Rod journalled in plates 1, vertically beneath the armature shaft. Fixed on the Rod, behind the front plate, is a  $\frac{3}{4}$ " Pinion 12 which meshes with a 50-teeth Gear Wheel 13 on a  $3\frac{1}{2}$ " Rod journalled in the plates alongside the previous Rod. A Collar is mounted on the Rod, in front of the plate, followed by a  $\frac{1}{2}$ " Pinion 14. This Pinion meshes with a  $2\frac{1}{2}$ " Gear Wheel 15 on another  $3\frac{1}{2}$ " Rod, above it, this Gear also being spaced from the plate by a Collar. A  $\frac{1}{2}$ " Pinion 16 is carried on the same Rod, behind the plate, this also meshing with a  $2\frac{1}{2}$ " Gear Wheel on a  $3\frac{1}{2}$ " Rod journalled above the previous Rod. A  $\frac{1}{2}$ " Pinion 17 on the front end of the Rod meshes with yet another  $2\frac{1}{2}$ " Gear Wheel 18 on a further  $3\frac{1}{2}$ " Rod, journalled alongside the previous Rod to the right, viewed from the front of the mechanism. A Collar behind the front plate holds the Rod in place.

A Threaded Pin 19 is tightly locked in one of the slotted holes in the face of Gear Wheel 18 and, as this Pin activates the "click-over" movement of the unit-minutes digit wheel, its position in the slot is critical. It lies approximately in the centre of the slot, but its exact final

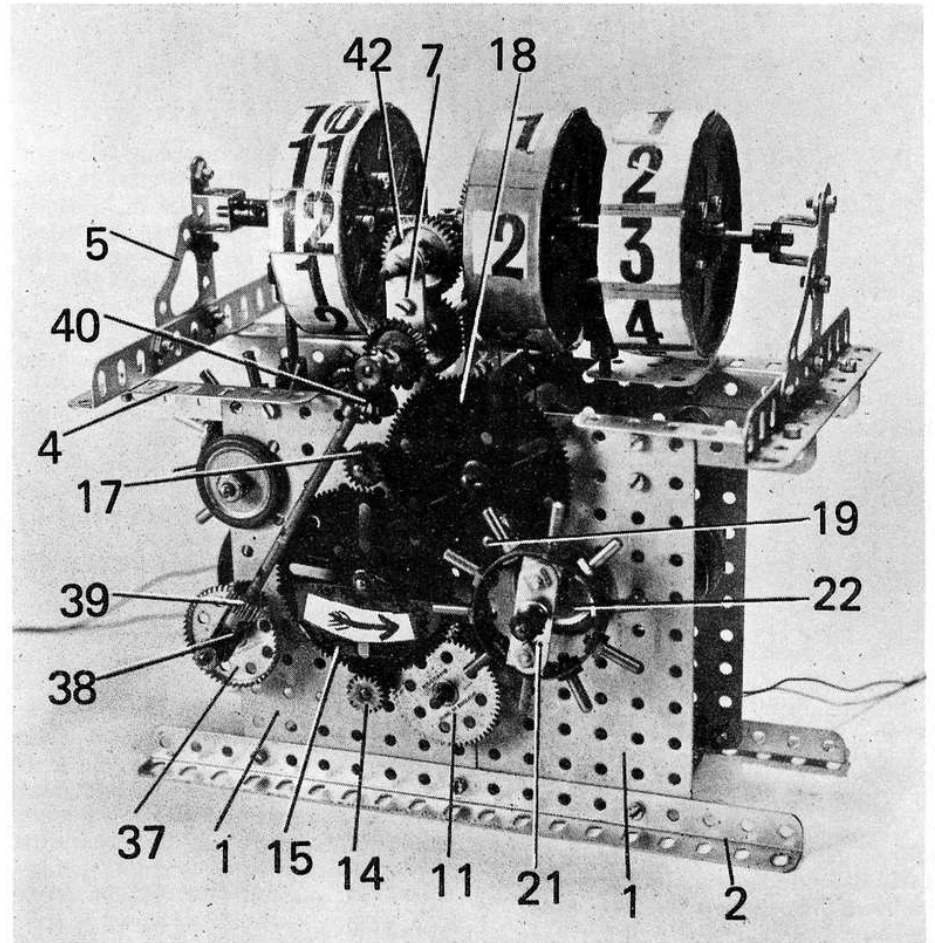

position should be determined under test when the completed mechanism is running.

### "PRONG WHEEL"

The Threaded Pin makes contact with the arms of a "prong wheel"

which is built up from a  $5\frac{1}{2}$ " Strip 20 which is very carefully shaped to form a ring, the ends of the Strip overlapping and being fixed together by a Threaded Pin which also fixes an Angle Bracket to the inside of the Strip. Another Angle Bracket, positioned diametrically opposite the first, is fixed to the Strip by another Threaded Pin, then the two Angle Brackets are connected by a Double Arm Crank 21. Eight further Threaded Pins are secured in the remaining holes in the Strip, then the complete unit is fixed on the outer end of a  $4\frac{1}{2}$ " Rod journalled in plates 1. The Rod is free to slide a short distance in its bearing, but is prevented from excessive movement by a friction plate provided by a 1" Pulley 22, fitted with a Rubber Ring and mounted on the Rod in front of front plate 1. The Pulley is held against the plate by the action of a Compression Spring carried on the Rod behind the plate and held in place by a Collar.

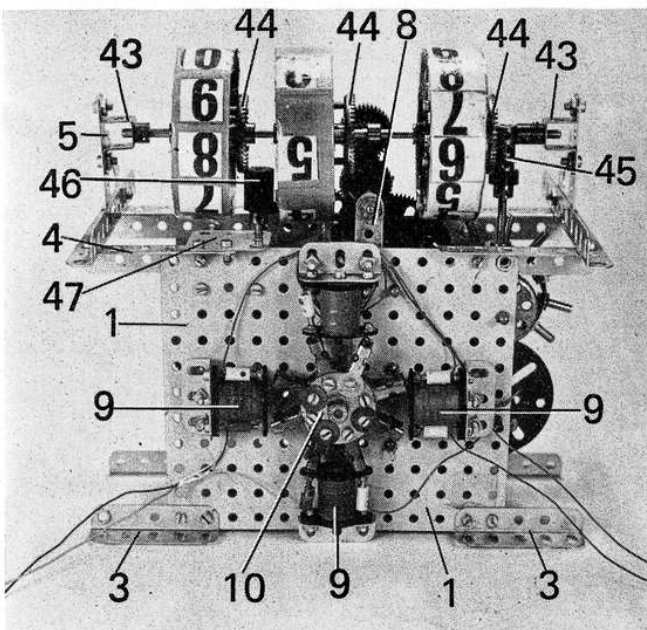

Opposite page: the finished 15 volt electric Digital Clock described in this article. Above: a front view of the Clock mechanism. To start the synchronous motor, Gear 15 is turned in the direction indicated by the arrow; a lot of very patient "flicking" may be necessary to reach the exact speed. Left: a rear view of the clock mechanism showing the built-up synchronous motor.

Also mounted on the Rod, between the plates, is an 8-hole Bush Wheel 23 and a  $1\frac{1}{2}$ " Contrate Wheel 24. Fixed by two Nuts in one of the holes in the face of the Bush Wheel is a  $1\frac{1}{8}$ " Bolt, its head



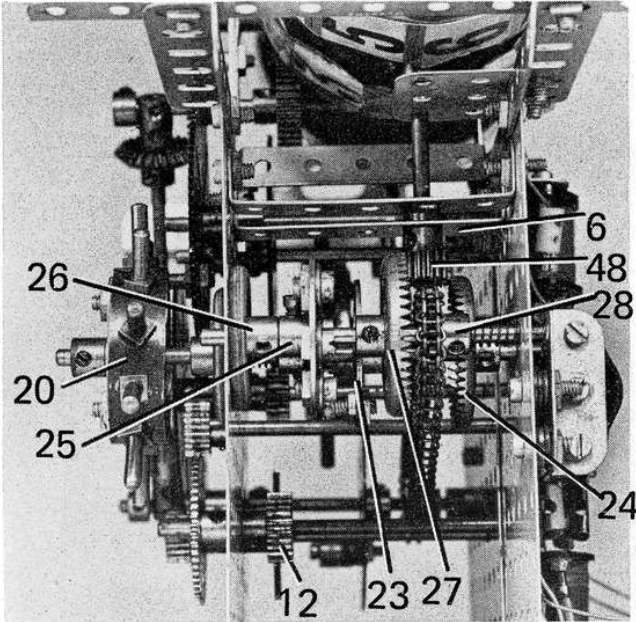

A close-up view of the Digital Clock mechanism, looking into the right-hand end of the unit. Prong wheel 20 controls the 'click-over' movement of the unit-minutes digit wheel, while Sprocket Wheel 28 extends drive, via Sprocket Chain, to the ten-minute digit train at the other end of the unit.

projecting approximately  $\frac{1}{4}$ " outwards. As the Bush Wheel revolves, this bolthead makes intermittent contact with the heads of six ordinary Bolts fixed in the holes in the face of a 6-hole Bush Wheel 25, mounted on a 3" Rod journalled alongside the previous Rod. Also mounted on this last Rod, in addition to Bush Wheel 25, are a 1" Pulley with Rubber Ring 26, a  $1\frac{1}{2}$ " Contrate Wheel 27, a  $\frac{3}{4}$ " Sprocket Wheel 28 and a Compression Spring. Pulley 26 with the Rubber Ring again serves as a friction plate, being held against the back of front plate 1 by the action of the Compression Spring.

Sprocket Wheel 28 is now connected by Chain to another  $\frac{3}{4}$ " Sprocket Wheel 29 fixed on a  $4\frac{1}{2}$ " Rod 30 held by Collars in plates 1 at the other end of the mechanism. Mounted on the Rod, between the plates, is a Face Plate 31, in one of the slotted holes in the face of which a  $\frac{3}{4}$ " Bolt is fixed by lock-nuts. Revolving, free, on the protruding shank of this Bolt are three Washers and a Collar 32, this unit serving as the "Click-over" activator for the digital hour wheel. As with the previous unit-minutes wheel, this activator engages with the arms, or teeth, of a "prong wheel" 33, this one built up from two  $3\frac{1}{2}$ " Strips curved to shape and fixed together to form a ring of  $6\frac{1}{2}$ " (thirteen holes) circumference. As before, Threaded Pins are tightly fixed in all the holes of the ring to radiate outwards and a Double Arm Crank is fixed across the diameter of the ring by two Angle Brackets, secured in diametrically opposite positions. Note that the Double Arm Crank is bolted to the

elongated hole lugs of the Angle Brackets.

The prong wheel is fixed on a  $3\frac{1}{2}$ " Rod journalled in the end row, third holes down of plates 1. Also mounted on the Rod, between the plates, are a fixed  $1\frac{1}{2}$ " Contrate Wheel 34, a loose Coupling 35 (the Rod passing through its lower transverse bore), a Collar and a Compression Spring, with a 1" Pulley with Rubber Ring 36 being fixed on the front end of the Rod. Again, the Pulley with Rubber Ring acts as a friction plate being held in contact with the front Flat Plate by the action of the Compression Spring.

Coupling 35 acts as the lower bearing for a vertical Rod, but, before dealing with this, it is better to complete the initial drive to the ten-minute digit wheel. Mounted on Rod 30 in front of front plate 1 is a fixed  $1\frac{1}{2}$ " Contrate Wheel 37 and a loose Short Coupling 38 held on the Rod by a Collar. The Rod passes through one transverse bore of the Coupling. Journalled, free, in the longitudinal bore of the Coupling is a  $4\frac{1}{2}$ " Rod, carrying a  $\frac{1}{2}$ " Pinion 39 (meshing with Contrate 38) and a  $\frac{7}{8}$ " Bevel Gear 40. The upper end of the Rod is also journalled in the longitudinal bore of a Short Coupling, this one held by a Collar on a 4" Rod mounted in the third holes down of Strips 7 and the upper end hole of Strip 8. Fixed on the Rod in front of Strips 7 is a  $\frac{7}{8}$ " Bevel Gear, which meshes with Bevel 40, while a 1" Gear Wheel 41 is fixed on the Rod behind the Strips.

In mesh with Gear Wheel 41 is a second 1" Gear 42 on a 2" Rod

journalled in the boss of the Crank bolted to the back of Strips 7, where it is held in place by the Gear Wheel and a Collar. A  $\frac{1}{2}$ " Pinion, boss inwards, is fixed on the inner end of the Rod.

## DIGIT WHEEL

Now bolted to the vertical arms of Corner Gussets 5 are two Double Bent Strips 43, which serve as bearings for an 8" Rod on which the three digit wheels are mounted, free. Each wheel is similarly built up from two 3" Pulleys, boss to boss, fixed together by  $1\frac{1}{8}$ " Bolts, on the outer ends of the shanks of which a  $1\frac{1}{2}$ " Contrate Wheel 44 is fixed. The wheels, being free to turn on the Rod, are held in position by Collars at each side. Strips of cardboard are wrapped around the wheels and fixed in place with sticky tape. Stuck to the card are the necessary clock numerals which must be evenly spaced around the wheels. We used  $\frac{3}{4}$ " numerals cut from some number-sheets we had available, but the numerals included in the Letraset or similar rub-on ranges would be ideal.

Also located, free, on the supporting Rod is a Coupling 45, the Rod passing through the end transverse bore of the Coupling. Revolving in the longitudinal bore of this Coupling and in the longitudinal bore of Coupling 35 is a 2" Rod on which two  $\frac{1}{2}$ " Pinions are fixed. The lower Pinion engages with Contrate Wheel 34, while the upper Pinion engages with the Contrate Wheel incorporated in the hour-digit wheel. The Contrate incorporated in the ten-minute digit wheel meshes with the  $\frac{1}{2}$ " Pinion on the same Rod as Gear Wheel 42, while the Contrate incorporated in the unit-minute digit wheel meshes with a  $\frac{1}{2}$ " x  $\frac{3}{4}$ " Pinion 46 on the upper end of a  $2\frac{1}{2}$ " Rod journalled in Double Angle Strip 6 and in the corner hole of a  $1\frac{1}{2}$ " x  $1\frac{1}{2}$ " Flat Plate 47 bolted to nearby Angle Girder 4. A  $\frac{1}{2}$ " Pinion 48 on the lower end of the Rod meshes with Contrate Wheel 24 and note that the Rod is prevented from sliding in its bearing by this Pinion and a Collar above the Double Angle Strip.

This completes the Clock mechanism and, before proceeding any further, it is advisable to test it thoroughly. Pay particular attention to the three friction plates provided by 1" Pulleys with Rubber Rings, making quite sure that they do not make too strong a contact with the Flat Plates. The friction plates are of

course provided to hold the digit wheels steady when stationary and the tension used should be no greater than the minimum required to ensure this.

### CASE

Turning now to the case, this can of course be built to your own design to conform to your own artistic tastes. In our model, however, the back is supplied by a simple square framework, built up from four 9½" Angle Girders 49, enclosed by four 9½" x 2½" Strip Plates, suitably overlapped. For the vertical front panel, a smaller rectangle is built up from two vertical 5½" Angle Girders 50, connected at top and bottom by two 9½" Angle Girders, the upper securing Bolts also holding a 9½" Flat Girder 51 in position. Three 5½" x 2½" Flexible Plates 52 are bolted between the 9½" Girders, the remaining space being enclosed by a door provided by a 4½" x 2½" Flat Plate 53 attached to one Girder 50 by two Hinges. A Handrail Support serves as the door knob.

The upper corners of Flat Girders 51 are extended by Obtuse Angle Brackets, to which is bolted a 9½" x 2½" Strip Plate 54, each end of which is overlaid by a 4" compound strip, built up from two 2½" Strips. The upper ends of these compound strips are connected by a 9½" Strip 55, the securing bolts also holding Obtuse Angle Brackets in place. Bolted between Strip 55 and Plate 54 are four 2½" x 1½" Flexible Plates and a 2" Strip 56, all arranged to leave appropriate "windows" for the clock numerals. Bolted to the Obtuse Angle Brackets and to upper Girder 49 is the case top, provided by a 9½" x 2½" Strip Plate with its ends overlaid by 3" Strips. The base is not enclosed, but the lower corners at front and back are connected together by a 5½" Angle Girder 57 in each case. Each side is built up from a 9½" x 2½" Strip Plate, a 5½" x 2½" and a 2½" x 1½" Flexible Plate and a 3½" x 2½" Triangular Flexible Plate, all bolted together and edged along the top by a 3" Strip. The lower end of the assembly is bolted to Angle Girder 57.

Needless to say, the clock unit must be fixed in place before the case is completed! Mounting is perfectly straight-forward: Angle Girders 3 and 4 are bolted to Girders 57, while the front end of the 5½" Angle Girder carrying Corner Gusset 5 is bolted to the 9½" Angle Girder behind Flat Girder 51 in the case front. With the Clock fixed in the completed case, of course, the arm-

Another close-up view of the clock mechanism, this time looking into the left-hand end of the unit. Prong Wheel 33 controls the 'click-over' movement of the hour digit wheel. Care should be taken when selecting all gears for the Clock to ensure that they are in no way bent or distorted.

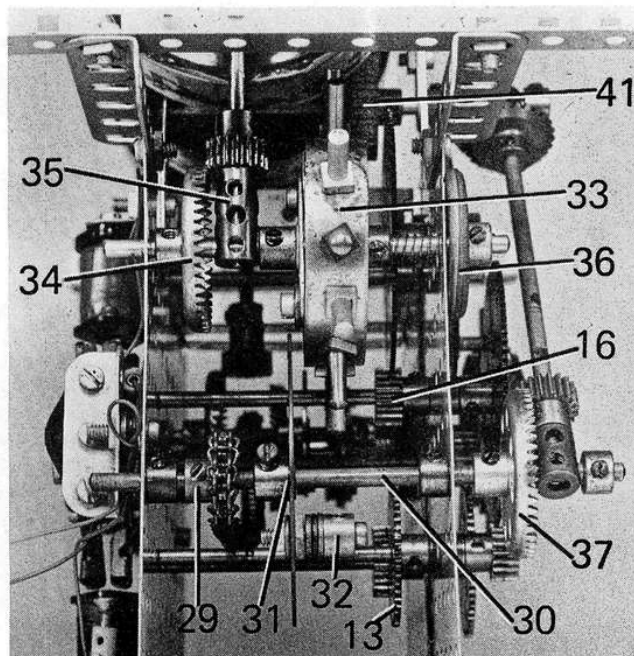

ature is inaccessible for spinning to start the synchronous motor. However, the same effect is achieved by turning Gear Wheel 15 in the direction indicated by the arrow and door 53 is, in fact, provided to allow easy access to the Gear.

Taken as a whole, the Meccano Digital Clock is an interesting and very useful model. It may not be as large, or as visually impressive as Bert Love's Grandfather Clock, but it does do the same job - keep the time - and it does it remarkably well. A good example of advanced Meccano modelling!

### PARTS REQUIRED

1- 1a	7-16	2-31	1-103a
1- 2	2-16a	170-37a	2-108
2- 3	1-17	152-37b	9-111
4- 4	6-19b	60-38	12-111d
4- 5	3-22	2-45	2-114
3- 6	3-24	3-48a	23-115
8- 8a	1-24b	1-52	2-120b
6- 9	1-25	4-52a	3-155
4- 9c	5-26	17-59	6-188
2- 9d	1-26b	2-62b	5-192
4- 9h	1-27	1-63	8-196
4-12	1-27a	2-63d	16-212
4-12c	3-27c	1-74	2-226
1-13a	6-28	1-94	4-522
1-15a	2-30	2-96a	4-528
2-15b			10-612

## THIRD ANNUAL MECCANO EXHIBITION

HENLEY-ON-THAMES Open Friday & Saturday,  
TOWN HALL. 10 a.m. - 6 p.m. 30th & 31st August.

Friday will be a special MECCANO enthusiast's day when readers of the MMQ, club members, model builders generally, and their families are invited to meet each other and display their work. On Saturday the Exhibition will also open to the general public.

Admission: Adults: Friday 25p. Saturday 10p.  
Exhibitors Free Children: Friday 10p. Saturday 5p.

MW Models 165, Reading Road, Henley-on-Thames, Oxon, RG9 1DP., England.