

APRIL 1924

MECCANO

MAGAZINE

Published in the interests of Boys



PRICE

2^{D.}

VOL. IX.

No. 4

The New Torque Converter

(see page 90)

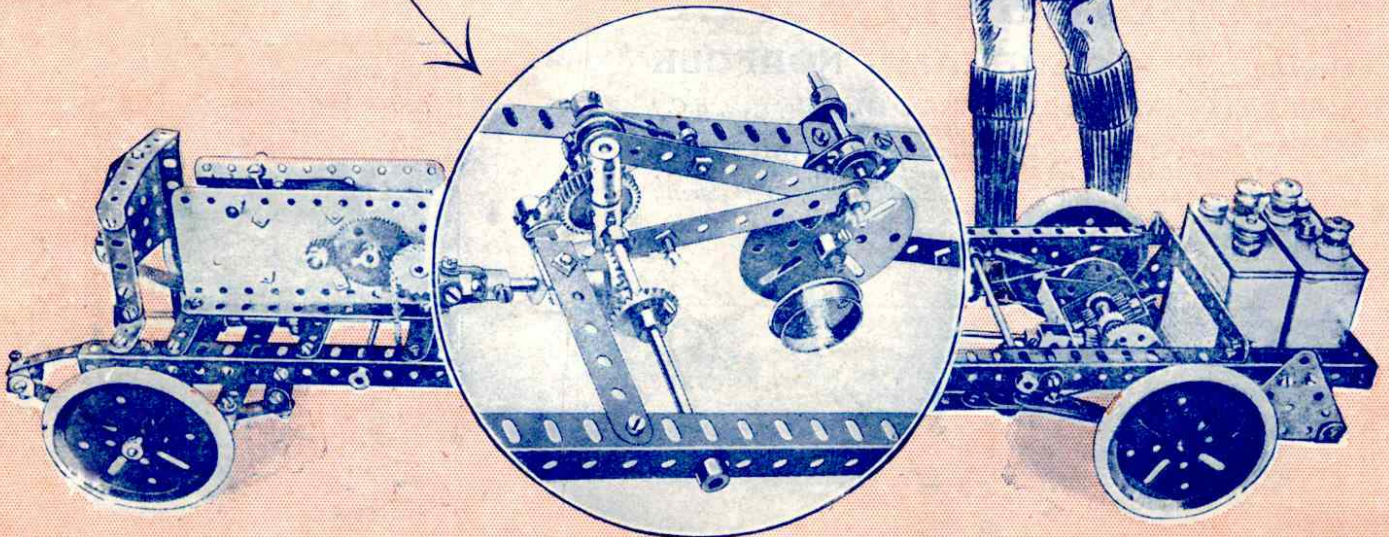
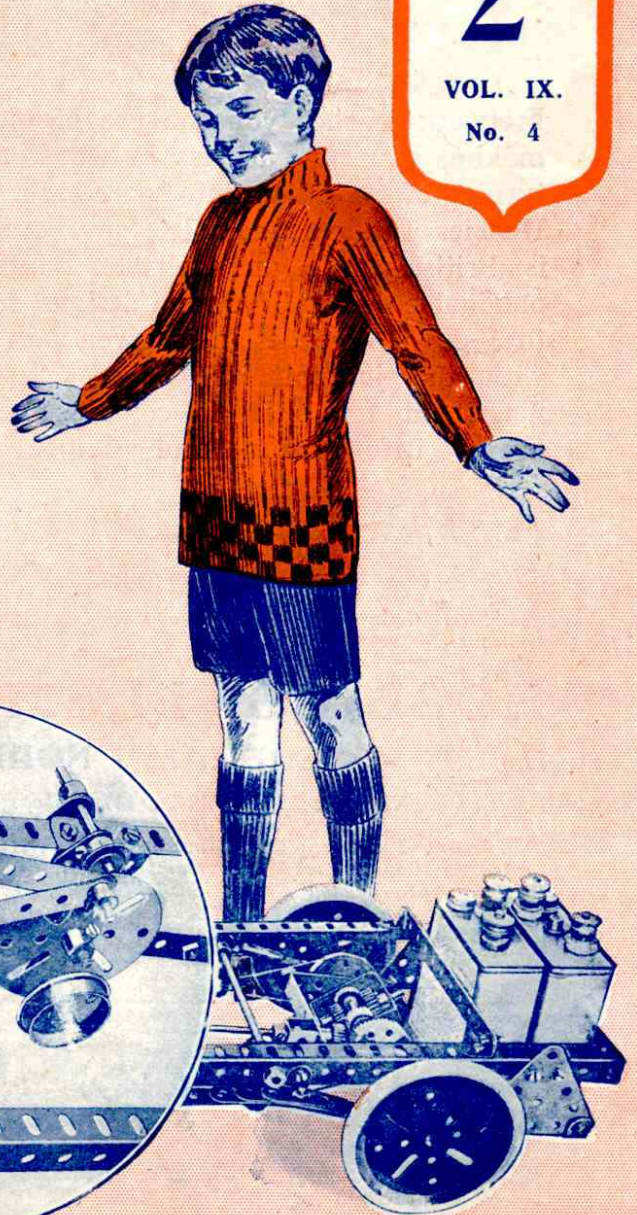

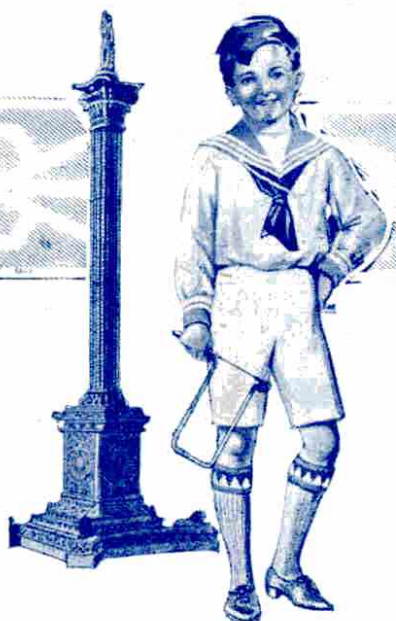

You can make money with this **FRETWORK OUTFIT**

Fretwork teaches you the use of tools, the making of useful articles in wood, and the turning of spare time into spare cash. Every Hobbies Outfit is complete and every tool is British made and reliable. Outfits are obtainable 4/- to 57/6, and designs from 1d. to 1/6. A free design is given every week with the journal "*Hobbies*." Ask your newsagent for one. It contains heaps of useful information and helpful hints.

A 1/6 DESIGN FREE

A Handsome Hanging Cabinet Design with each 1924 Catalogue. 200 Pages. 500 Designs. 15 Pastimes. Price 9d., or 1/- Post Free. Get your copy now at any Hobbies branch or any ironmonger or newsagent.

HOBBIES LIMITED

Dept. 96 - DEREHAM - NORFOLK

London : 65, New Oxford Street, W.C. ; 147, Bishopsgate, E.C. ;
79, Walworth Road, S.E. ; Glasgow : 326, Argyle Street ;
Manchester : 10a, Piccadilly ; Birmingham : 9a, High Street ;
Leeds : 15, County Arcade ; Southampton : 11, Bridge Street ;
Brighton : 68, London Road ; Sheffield : 214, West Street ;
and of all Agents.

The No. 2½ Complete OUTFIT

On Edged Card, 16" x 12".
Contains a 12" Handframe,
Archimedean Drill with 3
Bits, Cutting Table with
Iron Cramp, Six Sawblades,
Sandpaper Block, and Design

Price 6/6

Postage 6d. extra.

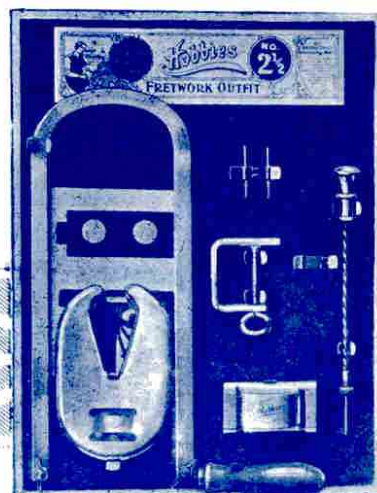

EDITORIAL OFFICE
Binns Road,
LIVERPOOL



MECCANO

MAGAZINE

PUBLISHED
IN THE INTERESTS
OF BOYS



EDITORIAL

AS my readers know, the Meccano Model-Building Competition is this year being run as a Championship Contest. As the Competition closes this month I thought it would be interesting to say a few words on this page in regard to the meaning of the word "Champion." I do not refer to the dictionary meaning of the word, which I find is "*One who, by defeating all rivals, has obtained an acknowledged supremacy,*" although a good deal might be said about this. I really wanted to write of the broader meaning of the word "Champion," and to remind you of the ancient glories associated with it.

There has been a healthy spirit of rivalry in almost every walk of life, from very early times. Those of my readers who have studied ancient history have read of the Olympic Games, the greatest of the national festivals of the ancient Greeks. The Olympic Games took place once every four years, the events lasting five days. Open to all free-born Greeks, the Games attracted champion athletes from all parts of Greece, who attended to show their strength and skill. Thousands of spectators, who came from all parts, watched the athletes competing against each other in wrestling and boxing bouts, long and short foot races, jumping, throwing the discus and javelin, chariot races and similar contests. The successful competitors received a wreath of olive and were maintained for the remainder of their lives by their native cities, and thus became the champion athletes of the cities concerned. As the Olympic Games were held long before 700 B.C. this is a very early example of Championship, expressing the spirit of rivalry.

There have been many other champions since those early days. Space forbids more than a mention of the Seven Champions of Christendom, of whom you will read in mediæval romances. These were the seven national saints, and included St. George of England, St. Andrew

of Scotland and St. David of Wales. Then there is the interesting story of the King's Champion. As the Champion of the Realm he challenged to single combat any person who should dispute his sovereign's title to the crown. This challenge took place at the Coronation banquet, when the Champion, in full armour with his helmet trimmed with red, white and blue plumes, rode into the famous Westminster Hall in London on the second best charger from the royal stables. While the heralds were proclaiming the challenge from the entrance to the Hall, the Champion threw down his gauntlet three times, and anyone who wished to accept the challenge only had to pick up the glove. The office of King's Champion is of great antiquity, and although the custom of the challenge was discontinued in George IV.'s time, the office of King's Champion still exists.

No doubt, many of you have read the fascinating stories of King Arthur and the Knights of the Round Table; of how these valiant knights devoted their lives to the cause of chivalry. They were the champions of the weak and oppressed, whom they were ever ready to defend against cruelty and injustice. These champions of the Age of Chivalry were fine characters and stand out as shining lights in the story of our country. In after years their spirit of bravery and honour did not die, but continued to live in the hearts of our countrymen. When the sacred places in the Holy Land were being destroyed by infidels, Englishmen were ready to brave danger and death in a strange country, and lead the first expedition into Palestine. The story of the Crusades is one of the most wonderful ever written. When we think of the gallant deeds and heroic characters of the Crusaders, we cannot help but feel proud that these champions of the Faith were our own countrymen.

Throughout the centuries, we find there have been champions of many kinds, although it is true these men were not always given the title of "Champion." There were champions of a belief, as Thomas à Becket. Champions of a nation, such as Nelson, Wellington, Clive, and Cecil Rhodes. Champions of industry, champions of science and champions of art—each of whom had his difficulties to overcome, as the earlier champions had their battles to fight. To-day we have champions of yet another kind—men who by hard and repeated tests have proved themselves unequalled in the world of sport. Boxing,

Next Month:

- NEW SERIAL ARTICLE :—
The Story of Iron and Steel
- FAMOUS ENGINEERS :—
George Stephenson (Part IV.)
- ELECTRICITY :—
Benjamin Franklin's Famous Experiment with Lightning
- STAMP COLLECTING :—
Watermarks. Some Interesting Recent Issues
- INTO THE LAND OF FUN :—
A New Meccano Model
- WHAT BROADCASTING MEANS :—
(II) Covering Britain with Broadcast
- COMPETITIONS, GUILD NEWS, CYCLING NOTES, PUZZLES, and other regular features

swimming, running, fencing, golf, lawn-tennis and every other form of sport, has its champion, who proves his claim to the title by being ready to defend it against any challenger. Strong and physically perfect, as the Olympian athletes of old, these modern champions have not attained the highest standard of perfection without a vast amount of hard work and strenuous training.

I think I have said sufficient for you to understand that there is a wealth of meaning in the word "Champion," and you will, perhaps, enter with greater zest into the competition for the Champion Model-Builder of your country, full particulars of which are announced on page 109. Thousands of boys all over the world will be competing against each other for the proud title of Meccano Champion—an honour well worth striving for. Although you cannot be a King's Champion, nor can you be a champion athlete of ancient Greece, you can be a champion model-builder and gain honour by winning the coveted Championship Cup for your own particular group. You may not be maintained free for life by the people of your home town, as were the Olympian champions, but there is no doubt that your friends will honour you, and your parents and relatives will be proud of you for having "defeated all rivals and obtained an acknowledged supremacy."



III. GEORGE STEPHENSON, the Man Who Gave Railways to the World.

THE establishment of the Stockton and Darlington Railway had been a great achievement and we may imagine that Stephenson was justly proud of his work. He had proved that he not only thoroughly understood the working and construction of a locomotive, but he had also shown himself a capable civil engineer, having surveyed the land for the railway and superintended the laying of the track. The experience he gained with the Stockton and Darlington Railway was of inestimable value to him in after life, and more particularly so in the difficult tasks that he was subsequently called upon to face.

Of these, perhaps the most difficult was the conquest of Chat Moss, a treacherous bog between Manchester and Liverpool. The story of this engineering feat is one of the greatest triumphs in the history of engineering.

The Liverpool and Manchester Railway Projected

The demand for a railway between Manchester and Liverpool increased as time went by, for the trade and manufactures of South Lancashire were growing extensively. This expansion was principally due to the invention of the steam engine and of the spinning jenny, which resulted in an enormous increase in manufactured cotton goods around Manchester and in other parts of Lancashire. The raw cotton, brought by sea to the port of Liverpool, had to be transported to Manchester and the spinning districts around it. The only method of transport at that time was by road, or by the Bridgewater Canal. The success of the Stockton and Darlington Railway, however, suggested the possibility of constructing a line between Manchester and Liverpool, as it was realised that a railway would afford a more satisfactory means of communication between the two towns than either the road or the canal.

Those who were proposing to construct a railway consulted Stephenson on the matter, and he eventually came to Liverpool to take charge of the work. The construction of this line illustrates very fully the qualities required in an engineer,

George Stephenson possessed unlimited perseverance—the essential quality for the making of an engineer. Early in life, when working as a brakesman at a colliery, he adopted as his motto the one word "Persevere." Keeping this before him as a shining light, he gradually climbed the ladder of life, rising from being a cow-herd at 2d. per day, to be one of the greatest engineers the world has ever known. His life is a worthy example of perseverance, thoroughness and enthusiasm that every Meccano boy may well keep before him.

for the work was obstructed by difficulties of every nature. Apart from the mechanical difficulties of the locomotives themselves, there were great masses of rock to be tunnelled, and a bog that presented an apparently insurmountable obstacle to the construction of the railway. There were also political and financial difficulties that would have been sufficient to dishearten any other man than Stephenson.

Parliamentary Difficulties

It was first necessary to obtain the sanction of Parliament to the scheme, and a Bill was promoted to this end. As may be imagined, there was considerable

opposition to the Bill, not only from stage-coach owners and others who believed that the development of the railway would mean a serious financial loss to them, but also from land-owners and Lords of the Manors, through whose estates it was proposed to lay the line.

We have not space in these pages to recount the interesting story of how, step by step, Stephenson overcame every difficulty. Suffice it to say that he himself appeared before the Parliamentary Committee to throw the whole of his weight into the argument in favour of the Bill. Before one of the sittings commenced Stephenson

informed the leading counsel for the Railway Company that he was confident he could make his locomotive travel at 20 miles an hour. This so alarmed the lawyer that he warned Stephenson that if he did not moderate his views and bring his proposed speed within "reasonable limits" he would not only wreck the whole of the Bill, but he himself would be regarded as a maniac fitted only for a lunatic asylum!

"Shunting" a Committee Man

Another celebrated incident occurred when Stephenson was appearing before the Committee. The inquiry was being directed to the dangers of travelling in a train going at such high speeds as nine miles an hour. One of the members of the Committee addressed the following question to Stephenson—"Suppose now one of your engines to be going along a railroad at the rate of nine or ten miles an hour, and that a cow were to stray upon the line and get in the way of the engine; would not that, think you, be a very awkward circumstance?"

"Yes," replied Stephenson with a twinkle in his eye, "very awkward—for the cow." Needless to say, the member of the Committee did not proceed further with his cross-examination, for—to use a railway phrase—he was "shunted."

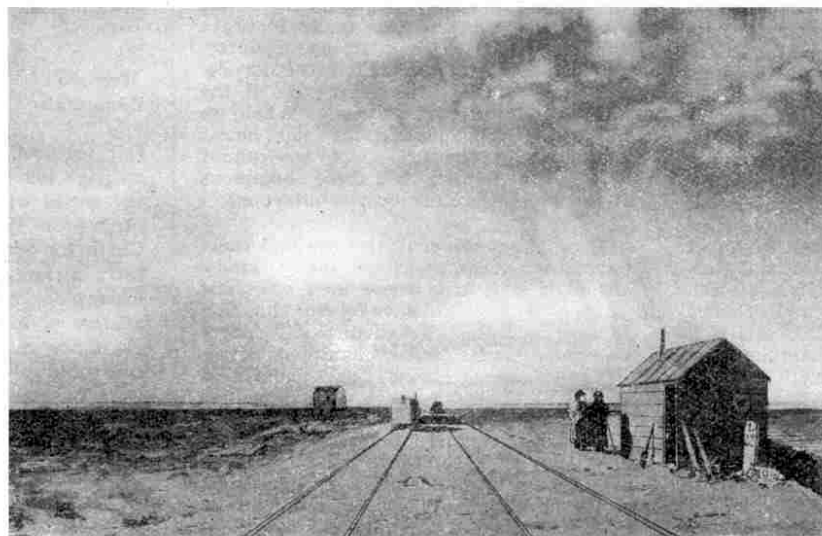

From an

The Dreary Waste of Chat Moss

Engraving

Chat Moss : A Vast Peat Bog

On the first occasion that the Liverpool and Manchester Railway Bill came before Parliament, it was not passed by the House. A new survey of the line had to be made. The second time the Bill was brought up the promoters were more fortunate, however, and it was passed by both the Commons and the Lords, in spite of the opposition.

Stephenson removed to Liverpool to superintend the work and commenced by undertaking a task that was regarded as being impossible to satisfactorily accomplish. This was the laying of a line over Chat Moss, a great peat bog, between Manchester and Liverpool. We are better able to appreciate the difficulties that were to be overcome when we learn that the bog was some twelve miles square and was composed of a mass of decayed vegetation; the growth and decay of ages. In wet weather the bog absorbed the rain like a huge sponge, and its centre stood several feet higher than its edges. In summer, when the water evaporated, the bog was left saucer-shaped, and at all times it was impossible for a man to walk across the bog, or even stand on it. Local tradition said that the bog had originated at the time of the Flood!

A Narrow Escape

Mr. Dixon, the Resident Engineer, inspecting the bog one day, slipped off the plank on which he was walking and sank to his knees. His struggles only sent him deeper, and he would have disappeared altogether but for the fact that workmen hastened to his assistance on planks. After this experience, it is not to be wondered at that Mr. Dixon was considerably exercised in his mind as to the wisdom of his chief in endeavouring to construct a road for heavy locomotives and trains of passengers and goods across a bog that he had found incapable of supporting his own weight!

When the Bill had been before Parliament some very scathing remarks were made in regard to Stephenson's suggestion to cross Chat Moss. "The making of an embankment out of this pulpy wet moss," declared counsel, "is no easy task. Who but Stephenson would have thought of entering into it? It is ignorance almost inconceivable. It is perfect madness to propose such a plan."

Another eminent engineer, called an expert witness by the opposition, said: "In my opinion unless a solid embankment can be built up from its bed no railway can be carried across the Moss without going to the bottom." The cost of this embankment the witness estimated would be £270,000. Another leading engineer—one of the most distinguished of his day—declared that the laying of the line across Chat Moss was "an impossible task that no man in his senses would undertake."

A Floating Railway

Stephenson was not put off by such assertions as these. He argued that just as snow-shoes distribute a man's weight over an area much greater than that occupied by his feet, so, too, would a platform built sufficiently large bear a railway track well above the bog. He did not intend to build an embankment such as was recommended, however, but to make the railway float on the surface of the bog. His idea was to construct a track of cross-sleepers, supported by a matting of heath and branches, so that the track was indeed a floating road or elongated raft across the bog.

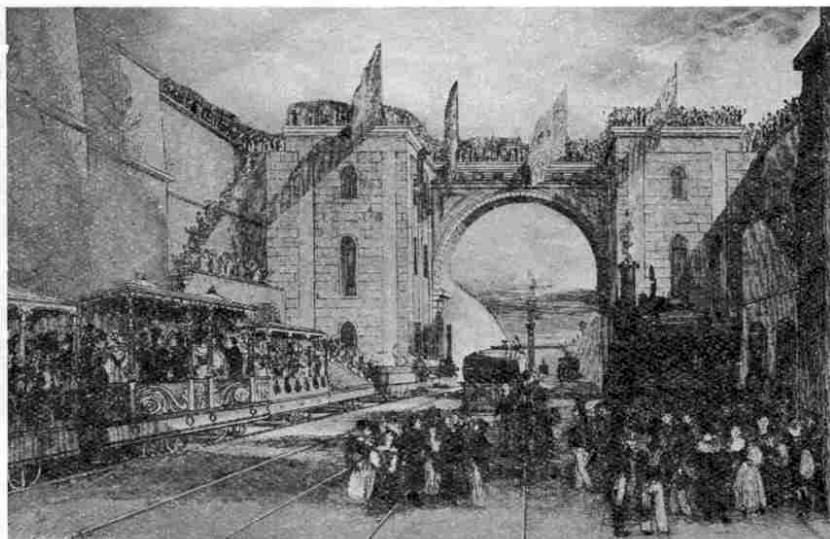

From an old

[engraving

The Opening of the Liverpool and Manchester Railway, September 15, 1830.
The scene at Edge Hill

Stephenson commenced his task by forming a footpath of heather across the bog, to enable the workmen to reach their work. He then strengthened this footpath so as to carry a narrow-gauge railway for the transport of materials necessary for constructing the permanent way.

Great difficulty was experienced in carrying the work to a successful conclusion, especially at the Manchester end of the line. Here the situation became alarming, for thousands of loads of heather, grass, tree branches and turf were spread on each side of the narrow pathway. These had no sooner attained the height of a few feet than the whole sank out of sight in the bog! Time after time this was repeated, and after some weeks' work there was so little trace of the workings, that had it not been for the ever-increasing total of the wages bills, it would almost have been believed that the task had never been commenced!

Stephenson's Self-Confidence

Describing this anxious time, Stephenson wrote, "After working for weeks and weeks in filling in materials to form the road, there did not yet appear to be the least sign of our being able to raise the solid embankment one single inch; in other words, we went on filling in without the slightest apparent effect. Even my assistants began to feel uneasy and to doubt the success of the scheme. The directors spoke of it as a hopeless task and at length they became seriously

alarmed—so much so indeed, that a Board meeting was held on Chat Moss to decide whether we should proceed any farther. There was no help for it, however, but to go on, as an enormous outlay had been incurred and great loss would have been occasioned had the scheme been abandoned and the line taken up another route. So the directors were compelled to go on with my plans—of the ultimate success of which I myself never for one moment doubted."

Stephenson's great confidence in himself is surprising, and we must admire his determination to "Persevere." He was not discouraged even in the face of the fact that on the one hand workmen who had lived in the district all their lives, and who might therefore be presumed to know something about local conditions, prophesied that his plan would never succeed and that by proceeding with it, he was only throwing good money after bad. Experts had declared that the task was impossible. Eminent engineers reported unfavourably upon it. Science and experience said, "If you knew as much about Chat Moss as we do, you would never have entered on so rash an undertaking. Depend upon it, all you have done and are doing will be fruitless. You must give up altogether the idea of floating a railway on the Moss and either fill in the bog and build a roadway of solid material, resting on the bottom, or else deviate the line so as to avoid Chat Moss altogether."

Success at Last!

Stephenson never lost heart, however, but true to his motto he "Persevered," and so the work went on. Load after load of material was tipped into the Moss every hour—and was swallowed up just as quickly.

At length the time came when Stephenson's wonderful optimism was rewarded, however, for the material had been doing its work out of sight, as he had said. It had been sinking through the bog and resting on the solid bottom of the Moss until gradually a bank rose above the surface. At length this bank was sufficiently long to be joined to the floating road already laid across the Moss from the Liverpool side. The road was finished by New Year's Day 1830, when the first train of passengers was drawn across it by the famous "Rocket." Chat Moss was vanquished, but not until over 670,000 cubic yards of turf had been used. The total cost of forming the line across the Moss was £28,000—a great difference between the £270,000 estimated by the eminent engineer mentioned above. The cost of the line across the Moss was, in fact, such that instead of it being the most expensive part of the line it was almost the cheapest.

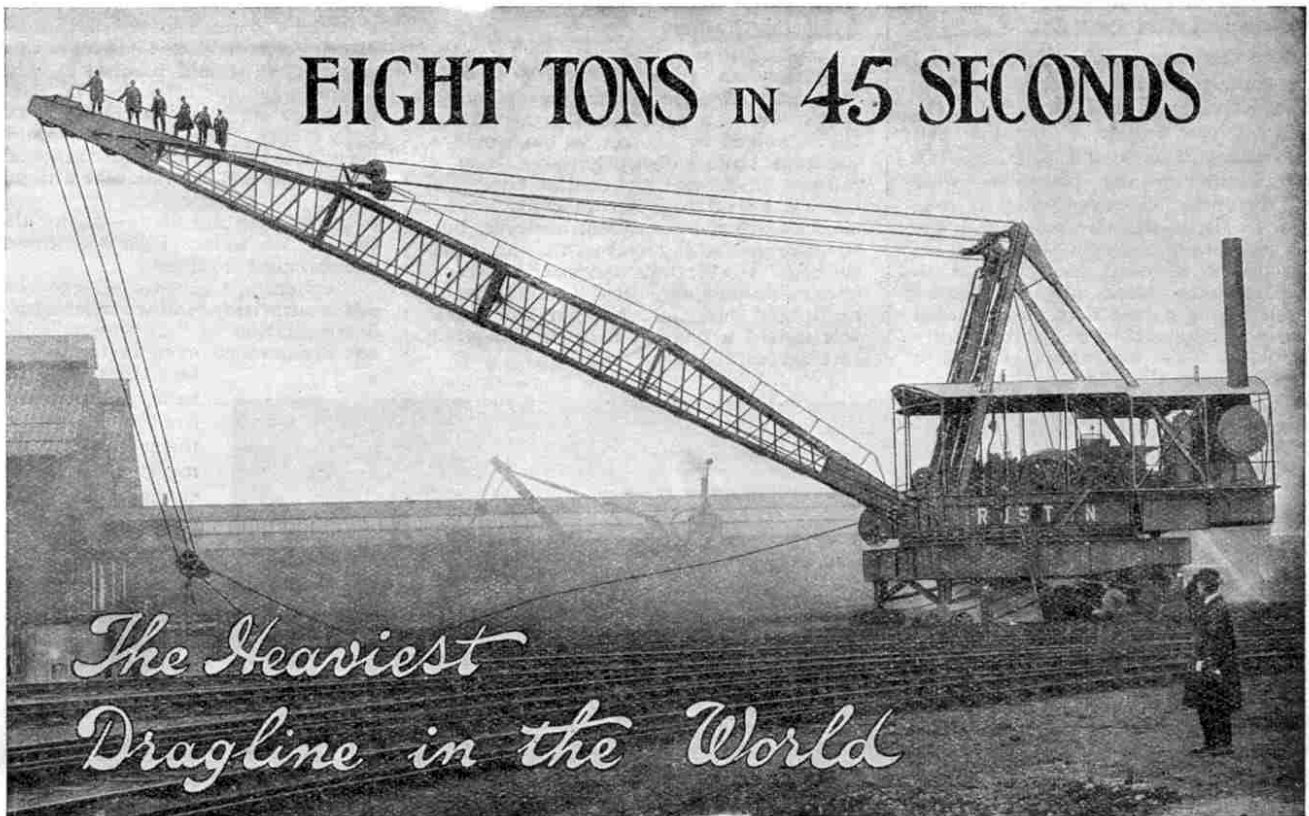

(Continued from last month)

The bucket of a Dragline is of simple construction, and being open at the front and the top, to a certain extent resembles a coal-scuttle. The digging rope is connected to a cross-bar, above the front of the bucket, the hoisting rope being fixed to the body of the bucket furthest away from the machine. The bucket is emptied by holding it up on the hoisting rope, and releasing the digging rope. This allows the bucket to tilt forward, and so discharges the contents from the open mouth.

In the cycle of operations of a Dragline the bucket is first lowered, at its extreme radius, to the foot of the excavation. By placing the winding drum in gear, the digging rope is then wound in, and hauling the bucket towards the machine, drags it into the material to be excavated. The thickness of the cut, or the depth to which the bucket is allowed to sink into the material, is regulated by the tension on the hoisting rope. If the depth is correct, the hoisting rope is allowed to unwind freely, or the cut may be made thinner by braking the drum around which it is wound.

Emptying the Bucket

When the bucket is full, the clutch is thrown out of the digging drum, and the hoisting gear engaged. The bucket is then lifted by the hoisting rope and the digging rope allowed to run freely, the bucket thus swinging towards the front of the jib. On the machine being slewed over the dumping point, the bucket is discharged in the manner already described.

When necessary, the bucket may be swung out beyond the radius of the jib

head, so as to take a larger radius of cut, by drawing in the bucket on the digging line and allowing it to run out as rapidly as possible, so that it swings beyond the jib head.

The Heaviest Dragline in the World

The illustration at the head of this article, which we print by courtesy of the manufacturers, Messrs. Ruston & Hornsby Ltd., shows the No. 250 Dragline. This is by far the largest excavator ever built in this country. In fact, we believe it is the heaviest of its type ever built by any-

slewing round, discharging, slewing back again and dropping the bucket in readiness for another cut.

The machine is being supplied for work in connection with the Indian irrigation schemes, which, by the way, will be the largest in the world. Some of the channels are to be over 200 ft. in width, and 12 ft. in depth, the excavated material being deposited upon the sides to form banks.

As a crane the machine will lift a load of 22 tons at 125 ft. radius, and although so large and heavy it is very easily controlled by means of steam clutches and steam brakes to all the motions.

Dragline does Work of 300 Men

For travelling the machine on rails, special swivelling bogies are used, all the wheels being driven. In less than one minute the machine digs 7 to 8 cubic yards of material

and deposits it 200 ft. away from the point where the material was taken out. In other words, this great excavator is capable of digging 300 to 400 cubic yards of material in an hour, and will deposit the material over 120 ft. from the centre of the machine, equalling the work of over 300 men.

£5 for Best Model Dragline

The giant Dragline illustrated in these pages forms such an excellent subject for a model that we suggested to Messrs. Ruston & Hornsby Limited, the makers of the original appliance, that they should offer a prize for the best Meccano model of their Dragline. They readily agreed to our suggestion, and we announce, therefore, a special Competition for the best model of this great Dragline, built with Meccano.

This is the second instalment of an article describing a remarkable machine that will play an important part in the history of engineering. A splendid competition with a cash prize of £5 has been arranged in connection with this article. For full particulars see the concluding paragraph on the next page.

one in the world. It weighs 250 tons nett and upwards of 300 tons when fully equipped and in working order. The bucket has a capacity of 8 cubic yards and would nearly fill an 8-ton coal wagon in one cut. The jib is 120 ft. in length and the drag-rope from the bucket $1\frac{3}{4}$ in. in diameter. A cutting power of 30 tons is exerted on the bucket teeth.

The machine's coal bunker has a capacity of 4 tons and is filled by means of a special steam-operated hoist. The main engines are upwards of 400 h.p. and, in addition, separate engines of about 200 h.p. are fitted for slewing the machine.

Designed for India

The cycle of operations is completed in 45 to 55 seconds, including digging,

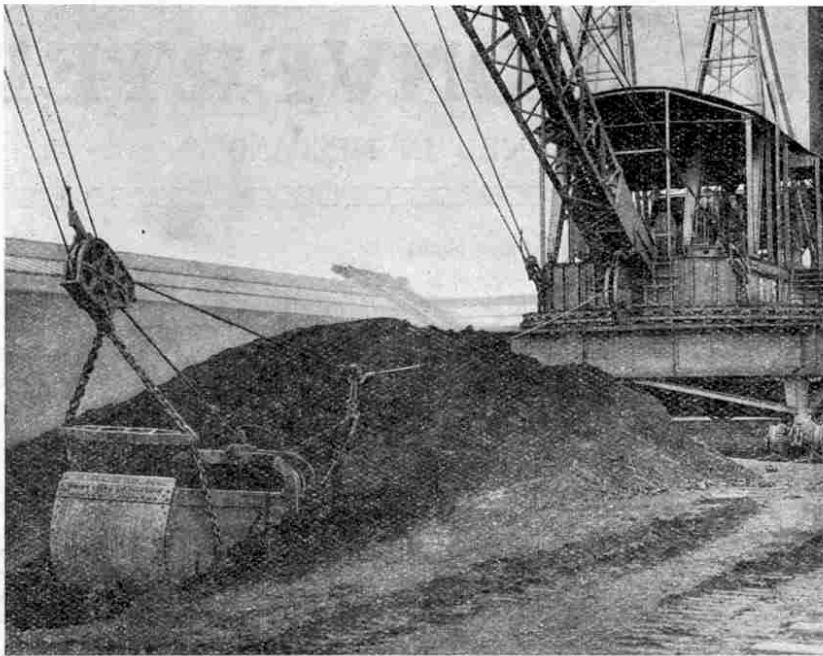

The bucket of a Dragline digs its way into the material to be excavated. It is dragged towards the machine and is emptied by releasing the dragging rope. Its contents are then discharged through the open end

Eight Tons in 45 Seconds—(cont.)

The first prize will be a cheque for £5 awarded by Messrs. Ruston & Hornsby Limited. Second and third prizes of Meccano products to the value of £3 3s. 0d. and £2 2s. 0d. respectively, to be chosen by the winner, will be awarded by Messrs. Meccano Limited.

There will be no age limit and any size Meccano Outfit may be used. Entrants should, however, state their age and the number of Outfit used, as this will be taken into consideration in making the awards. The Competition will close on the 30th September next. Actual models should not be submitted, but drawings or photographs should be sent, together with a description of the special features of the model entered, and on these the awards will be made. We shall illustrate a Meccano model of the Dragline, when announcing the results of this Competition in our November issue.

We hope that our readers will set to work and evolve a model worthy of the subject.

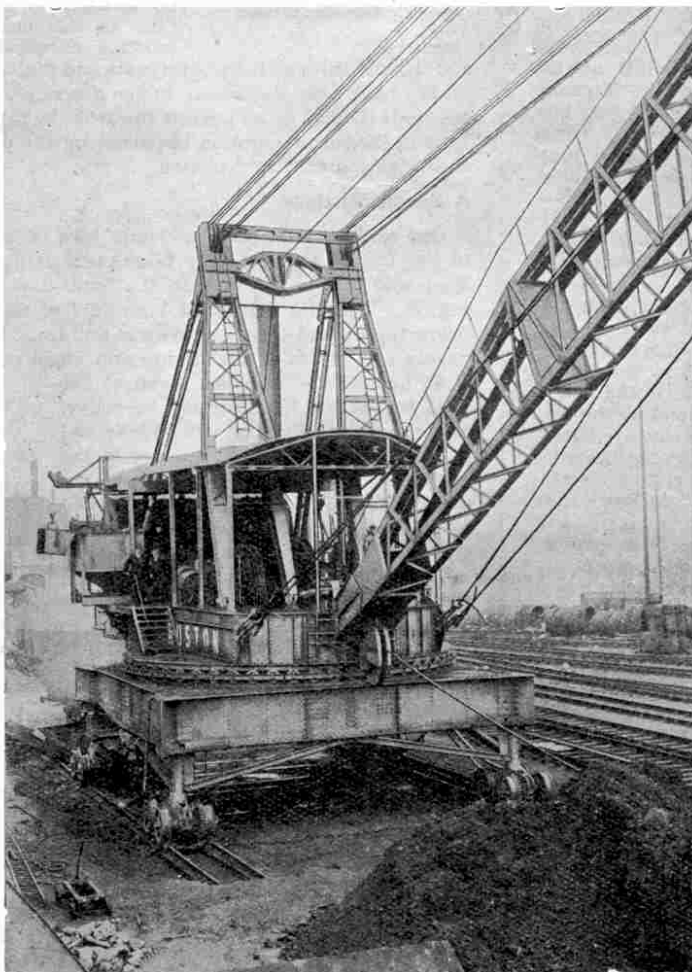

A near view of the mechanism that operates the heaviest Dragline in the world

OUR MAIL BAG



In this column the Editor replies to letters from his readers, from whom he is always pleased to hear. He receives hundreds of letters each day, but only those that deal with matters of general interest can be dealt with here. Correspondents will help the Editor if they will write neatly in ink and on one side of the paper only.

R. Kirkwood (Bath).—We are glad you like the "M.M." so much. Your suggestion that we start a column for animals and domestic pets, is no doubt a good one, but we require all our space at present to do full justice to our already numerous features. Perhaps we shall be able to arrange it a little later.

M. Vaccard (Milan).—We are always pleased to have letters from you in your own language, and there is no need for you to have them translated into English. Your suggestion that we publish several new models each month, one for each Meccano Outfit, makes us gasp a little!

J. Judge (Midsomer Norton).—

"Yes, we have some Meccanos
We've lots of Meccano to-day,
We've long strips and short strips,
And bent strips and flat strips,
And all kinds of strips, I say."

Sorry we cannot find room for all your verses, James, but this one is certainly a good effort. We experienced no difficulty in finding a suitable tune for it! We hope your father will soon be in harness and hard at work again.

T. McKelvie (Auckland, N.Z.).—We have heard of your "little country," as you call it. In fact, it happens to be a country in which we take an intensely keen interest. We know many people who live there; we know it geographically, commercially and ethnologically, and all we know of it is good! We will find a suitable English correspondent for you. Don't wait to be asked to join a Meccano Club—start one yourself and put your back into the work.

L. O'Brien (Johannesburg, S.A.).—We read your letter with much pleasure, and we congratulate you on your school successes. We hope you will enter your new model in our big competition. Write us again.

J. Sears (Watford).—

"There was an old lady of Clewer,
Who rode on a bike and it threw 'er.
A butcher came by
Said 'Missis, don't cry!
And fastened her on with a skewer!"

A Meccano boy would, of course, have fixed her up in a much more secure fashion with nuts and bolts and strips.

Kenneth Haynes (Maidenhead).—Your suggestions for running a Meccano Field and Nature Club are both interesting and useful. The requests for a Nature Section are numerous, and we are seriously considering the matter.

W. G. Hartley (Birmingham).—

"Life is mostly froth and bubble;
Two things stand like stone—
Building models with Meccano,
Letting work alone."

We were much impressed with your poetry, Walter, until we came to the last line, which made us elevate our eyebrows a little. Perhaps some of our readers can think of a better line to replace the offending one. We will give half-a-crown for the best effort.

E. V. Corps (Northampton).—First let us congratulate you on your success in your Chemistry exam. Your suggestion for a "Readers' Own Corner" in which letters from Meccano boys would be the principal feature is good, and we may adopt it later. We note you liked the tongue-twisters in our Xmas number, and shall give some more of these in a future number. We agree that a man in the condition you name might have some difficulty in saying "Agricultural statistics!"

G. H. B. Stafford (Pitsmoor).—We are pleased to receive your first letter, although, as you have been a keen Meccano boy for eight years, you really should have written to us long ago! You are both wise and fortunate in having so many enjoyable hobbies. We have read with interest the programmes of the two organ recitals which you have given at your church, and are glad to have a copy of the music which you have composed.

H. Hurdle (Hornsey).—We are writing to you separately about the nearest Meccano Clubs, and we hope you will have joined one of them by this time. Thanks for your suggestion that we provide Meccano flags for decorating models; this we may consider later.

THE TORQUE CONVERTER

REMARKABLE INVENTION REPRODUCED IN MECCANO

It has always been claimed for Meccano that any movement known in mechanics may be reproduced in model form. A striking vindication of this claim is furnished by the model of the Constantinesco Torque Converter. This model clearly demonstrates the working principle of this new device, which, incidentally, is stated to be based on principles understood only by those having a knowledge of advanced mechanics and mathematics. The fact that it is possible to reproduce in Meccano so highly technical a piece of apparatus is in itself a striking tribute to the Meccano system.

An Invention of Promise

The Torque Converter created a considerable sensation in engineering circles a short time ago and was briefly described in our February issue, in our interview with Mr. George Constantinesco, the inventor. We believe that there is a great future before this remarkable invention, and for some time past our model-building department has been at work endeavouring to evolve a model of the Converter in Meccano. After some considerable experiment we have succeeded in perfecting a model that, although not built on the same lines as the actual Constantinesco Converter, admirably fulfils the purpose of demonstrating the remarkable principle on which the original Converter is based.

This model will be of general interest to readers of the "M.M." More especially will it interest those who are contemplating building the model of the Meccano Chassis, and who are desirous of eliminating the standard gear-box and clutch and incorporating the latest invention instead. Those of our readers who have already constructed the Chassis may build the Torque Converter into their existing model without difficulty.

Motor Cars Without Gears

We may here explain that there are two main ideas behind the Constantinesco invention. One is that it makes possible the construction of motor cars without clutches or gears, and the other that it fulfils the purpose of an infinitely variable gear that automatically adjusts itself to the conditions imposed by the nature of the gradient on which the car is travelling and by the load on the car. Cars fitted with the device are therefore controlled simply by the throttle, which governs the engine speed. The inventor recently declared that he believes his Torque Converter will revolutionise all forms of transport, for it is not confined to the motor car alone, but may be applied with equal success to locomotives, aeroplanes, ploughs, tractors and indeed all similar forms of vehicles.

One of the great advantages of such an invention is that vehicles will require engines of only about half the size of the engines used to-day. Not only will an economy in petrol and oil consumption be effected, but the complicated mechanism of engines with four, six, or eight cylinders will be eliminated and the costly material, machinery and labour used in their manufacture will no longer be necessary. In future an engine with a single cylinder, and perhaps a cheap two-cycle engine, may be sufficient to drive almost any vehicle.

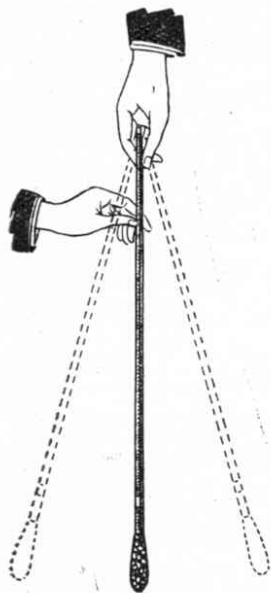

Fig. 2

Principle of Our Model

In an interview, Mr. Constantinesco informed us that without falling back on advanced mathematics and highly technical engineering knowledge it was impossible for him to explain how he obtained his results in such a manner that the non-technical reader could understand. If the inventor himself found it impossible to give this information, our readers will realise that we are confronted by a task of some difficulty in ourselves endeavouring to explain the principle of the Torque Converter! We propose, therefore, to simplify matters by confining our explanation to the working of the Meccano model of the Converter. We wish, however, to again emphasise the fact that this model is not a replica of the actual device—it is a model by which the working principle of the Converter is demonstrated.

A diagram of the working of the model is given in Fig. 1. The crank (A) driven by the engine, is connected to a lever (B), to the lower end of which is fixed a heavy weight (C) forming a pendulum. The other end of the lever (B) is connected to two rods (D and E) carrying pawls (F and G) which bear on a ratchet wheel (J). In this manner the torque, or twisting effect, is delivered to the rod (K) and through it by bevel gears and shaft (L) to the differential on the back axle (not shown in the diagram). No matter whether the rods (D and E) be pushed towards the ratchet or pulled away from it, the turning motion imparted by the pawls to the rod (K) is always constant in direction.

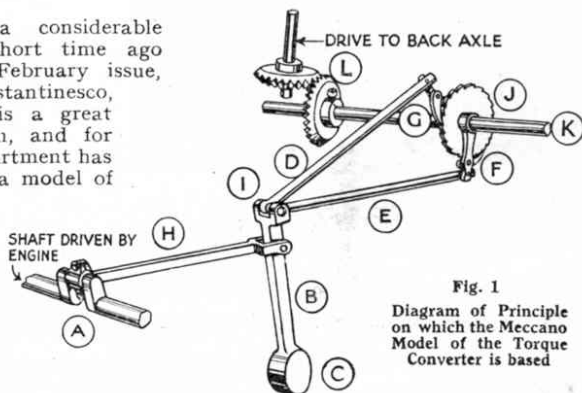

Fig. 1
Diagram of Principle on which the Meccano Model of the Torque Converter is based

A Simple Analogy

Our readers will obtain a clearer idea of the working principle of the Torque Converter by taking a walking stick with a heavy knob and suspending it with the knob downwards, as shown in Fig. 2. With the left hand take hold of the stick a few inches below the tip and swing it gently to and fro. Notice that it swings evenly and pivots in the thumb and finger of the right hand.

As long as the impulses given to the stick by the left hand are not excessive, the swinging of the stick will be easy and pendulum-like. If the frequency of the impulses be increased, however, a different state is set up, as is evidenced by an increase in pressure conveyed to the right hand acting as a pivot for the stick. As the impulses increase in frequency, a change in equilibrium takes place. Instead of the stick tending to pivot between the finger and thumb of the right hand, the pivot shifts down the stick, until at last—given a sufficiently high frequency—it moves to the opposite end of the stick and the heavy knob at the end of the stick becomes the pivotal point, while the pendulum-like movements are now carried out by the hand in which the stick originally pivoted.

An Irresistible Force

This change is made manifest in a remarkable manner to the person holding the stick. As the impulses increase in intensity, the hand holding the tip of the stick finds itself compelled to yield to an irresistible increasing pressure. It

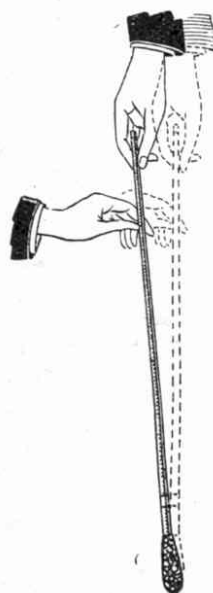

Fig. 3

is moved backwards and forwards by a powerful superior force, oscillating this way and that, with a degree that depends entirely on the frequency of the impulses received by the stick.

The original conditions have thus become entirely reversed. Instead of the knob oscillating to and fro and the right hand remaining at rest, with the tip of the stick pivoting in the finger and thumb, the knob ceases to oscillate and becomes the point on which both stick and supporting hand now pivot. The oscillations originally performed by the knob are transferred to the other end of the stick and are now performed by the right hand. Expressed in engineering language, it would be said that the fulcrum has receded.

It is important to realise that the pivotal point does not change suddenly from the tip of the stick to the knob, but moves slowly from one to the other, according to the frequency of the impulses received by the stick. If these are not sufficient the fulcrum may never reach the knob. If the frequency varies, the position of the fulcrum will vary also every instant, its location alternating momentarily between the tip and the knob. If the oscillations decrease in intensity beyond a certain point, the pivotal point returns to the tip and the original order of things is restored.

This is the principle on which the Constantesco Torque Converter is based, and the Meccano model works on the same principle. In it the hand moving the stick is replaced by the connecting rod (H Fig. 1) coupled to a crank (A). The place of the hand forming the pivot is taken by the bolt (I) which carries the rods (D and E) in our diagram. Impulses from the crank are transferred to the pawls (F and G), which in turn pass on the impulses—now converted into a turning movement—to the driving shaft.

“ How It Works ”

When the engine is running slowly only a slight swinging movement is given to the lever carrying the weight, which movement is not sufficient to move the pawls on the gear wheels. As the speed of the engine increases, however, the weight is compelled to swing faster and faster, imposing an increasingly heavy force or load upon the pawls. At length this load becomes so great that the resistance of the back axle is overcome; the pawls move the gear wheel and the driving shaft, and the car moves slowly forward, to gather speed subsequently.

The conditions of our analogy in Fig. 2 are simulated when the weight (C Fig. 1) swings without imparting any movement

to the shaft, through the ratchets. On the other hand, when the engine is running rapidly the fulcrum recedes and the weight (C) becomes the pivot, as it cannot respond to the rapidly-repeated impulses of the rod (H) with sufficient rapidity.

The condition illustrated in Fig. 3 arises when the resistance caused by starting up the car is overcome, and when the lever pivots on the weight (C). In these circumstances the drive from the engine is practically a direct drive to the back axle.

are mounted on short rods secured in the outer holes of the coupling (shown more clearly in Fig. 5), these pawls, being controlled by short tension springs (14) so that they are kept in contact with a 1" gear wheel (15). When moving in one direction they trail idly over this gear wheel, but when moving in the other direction, they drive the gear wheel (15) and consequently the rod (11) to which the wheel is secured.

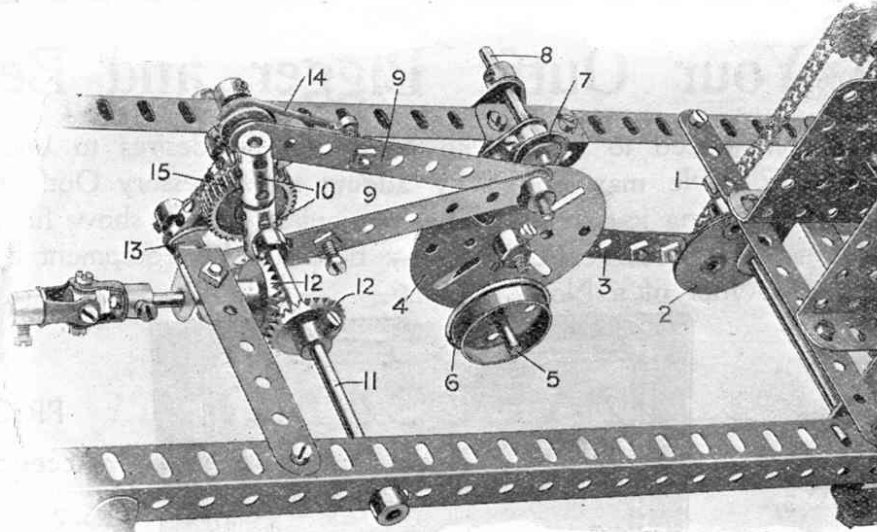

Fig. 4. The Converter in Meccano

Building the Meccano Model

The Meccano model of the Torque Converter may be constructed as follows. The rod 1 (Fig. 4) is rotated by a sprocket chain from the electric motor fitted to the chassis. This rod carries a triple throw eccentric (2) which is connected by a 3" strip (3) to the centre of a face plate (4). A short rod (5) passes through the lower hole of the face plate and carries two flanged wheels (6) which act as the pendulum weight. The rod (5) and the weights (6) are suspended by two cranks (7) from the short pivotal rod (8) mounted on the main member of the frame as shown. Two 4½" strips (9) are connected to the top hole of the face plate (4) and their other ends are connected to elements each formed by two couplings (10) secured on short rods, the couplings rocking loosely on the driven rod (11) from which the drive to the differential is conveyed through the bevels (12). Two pawls (13)

gear accommodates itself automatically to the work to be done.

In operation the rod (1) is rotated by the motor, the eccentric (2) tends to drive the strips (9) to and fro as the weight oscillates. This to and fro movement of the strips (9) results in a corresponding movement of the pawls. As the pawls are mounted to lie in opposite directions round the gear wheel (15) the latter is driven in one constant direction in a series of pulsations.

Remarkable Power Obtained

An interesting detail is the remarkable increase in power obtainable even from so small a form of Converter as that adopted in the Meccano model. This is demonstrated by jacking up the rear axle to allow the driving wheels to freely rotate, when it has been found impossible to prevent the revolution of the driving shaft when gripped with the finger and thumb below the universal joint. When it is

remembered that the driving force is obtained only from a small electric motor, driven by a 4-volt accumulator, the remarkable power imparted by the Torque Converter becomes apparent. By holding the shaft with greater or less degree of pressure the Converter may be made to demonstrate its automatic adjustment to a varying load or resistance in a remarkably effective manner.

Automatic “ Gear ” Adjustment

The automatic adjustment of the gear to the load and to the gradient is one of the most interesting

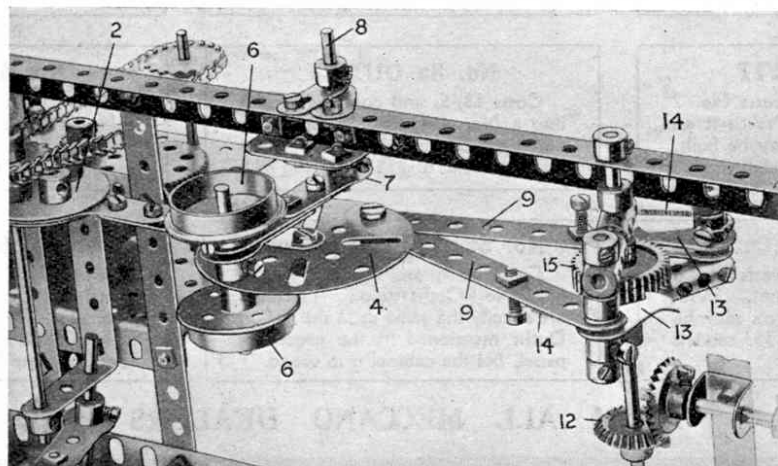

Fig. 5. Underneath View of Converter

(Continued on page 107)

MECCANO

ACCESSORY OUTFITS

Make Your Outfit Bigger and Better

Once a boy has commenced to build with Meccano, he desires to build larger and more ambitious models. He may do so by adding an Accessory Outfit to his existing set, thereby greatly increasing its scope. The particulars below show how a boy who commences with one of the earlier Outfits may build up his equipment by easy stages, until he is the proud owner of a No. 7 Outfit.

PRICE LIST

Complete Outfits

No. 00	3/6
No. 0	5/-
No. 1	8/6
No. 2	15/-
No. 3	22/6
No. 4	40/-
No. 5	(In well-made carton)		55/-
No. 5	(In superior oak cabinet with lock & key)		85/-
No. 6	(In well-made carton)		105/-
No. 6	(In superior oak cabinet with lock & key)		140/-
No. 7	(In superior oak cabinet with lock & key)		370/-



PRICE LIST

Accessory Outfits

No. 00a	1/6
No. 0a	4/-
No. 1a	7/6
No. 2a	8/6
No. 3a	18/6
No. 4a	15/-
No. 5a	(carton)	...	50/-
No. 5a	(wood)	...	80/-
No. 6a	210/-

This illustration shows a No. 3a Outfit which converts a No. 3 into a No. 4 Outfit.

No. 00a OUTFIT

Costs 1/6, and converts No. 00 into a No. 0 Outfit. With it an additional 27 models may be built, making a total of 70 models in all.

No. 0a OUTFIT

Costs 4/-, and converts No. 0 into a No. 1 Outfit. With it an additional 36 models may be built, making a total of 106 models in all.

No. 1a OUTFIT

Costs 7/6, and converts No. 1 into a No. 2 Outfit. With it an additional 57 models may be built, making a total of 163 models in all.

No. 2a OUTFIT

Costs 8/6, and converts No. 2 into a No. 3 Outfit. With it an additional 43 models may be built, making a total of 206 models in all.

No. 3a OUTFIT

Costs 18/6, and converts No. 3 into a No. 4 Outfit. With it an additional 53 models may be built, making a total of 259 models in all.

No. 4a OUTFIT

Costs 15/-, and converts No. 4 into a No. 5 Outfit (carton). With it an additional 43 models may be built, making a total of 302 models in all.

No. 5a OUTFIT (Carton)

Costs 50/-, and converts No. 5 into a No. 6 Outfit (carton). With it an additional 51 models may be built, making a total of 353 models in all.

No. 5a OUTFIT (Wood)

Costs 80/-, and converts No. 5 into a No. 6 Outfit (wood). The parts are exactly the same as in the carton Outfit mentioned in the preceding panel, but the cabinet is in wood.

No. 6a OUTFIT

Costs 210/-, and converts No. 6 Outfit into a No. 7 Outfit (oak cabinet). This Outfit builds every one of the 393 models illustrated in the Complete Manual.

FROM ALL MECCANO DEALERS



Into the Land of Fun

by
"SPANNER"



New Meccano Parts and their Uses

HOW many times, when building some new model, have we not all said, "If only we had a curved brace girder"—or perhaps it was a corner brace, or some special kind of strip or flat plate that we required at that particular moment. There must be hundreds of Meccano boys who say "If we only had a . . ." every day, although they do not all send their suggestions to the "Bright Ideas" column for consideration.



No. 119. Large Wheel Segment

Nevertheless, the suggestions received for additions to the Meccano system are very numerous indeed. Last year, when visiting the Meccano factory, I was told that the model-building staff spend many hours every day "trying out" these "Bright Ideas." Some seem very promising on paper, but when they are put into practice, their short-comings are at once apparent. If these difficulties cannot be overcome, the idea has to be discarded.

Two of the chief characteristics of the Meccano system are its standardisation and its great adaptability. These have been arrived at only by the possibility of being able to use almost every part for a variety of different purposes. Many ideas have to be turned down because the parts suggested serve only a single purpose, and they cannot therefore be given a place in a system, the key-note of which is "adaptability."



No. 137
Wheel Flange

Then again some "Bright Ideas" for new parts are not practicable from a manufacturing point of view, although the parts themselves would no doubt add to the usefulness of the system. A suggestion may be for a new part that, if made, could only be sold at £1 or more—so here again the "Bright Idea" cannot be proceeded with, on commercial grounds alone.

In addition to the above, however, there is one other reason why many "Bright Ideas" are not proceeded with, and this concerns by far the greater number of new parts suggested. These are not made use of because of the fact that parts already exist in the Meccano system that make quite satisfactory substitutes. As an example of this, I hear that very many requests have been received for a flanged wheel of 2½" diameter. Now a wheel of this diameter may easily be made by attaching a Flanged Disc to a Face Plate. Thus it would obviously be a waste of material to



No. 140
Universal Coupling

manufacture a special 2½" Flanged Wheel and include it in the system.

When chatting with Mr. Hornby on the subject of "Bright Ideas," I was very impressed to learn that every suggestion received is considered by the building readers some idea this means learned of thousands of "Bright Ideas" from all over the world are received at the Meccano Offices in the course of a year! Some of the ideas submitted do prove really practical and useful, and wherever possible these are invariably adopted. The inventors, enthusiastic Meccano boys themselves, have the satisfaction of knowing that they have materially contributed to the enjoyment and success of thousands of model builders all over the world.



No. 19c. Pulley Wheel

Some of the more recent new parts are illustrated on this page, and as their uses may not yet be familiar to all my readers, I intend to describe how each may be employed.

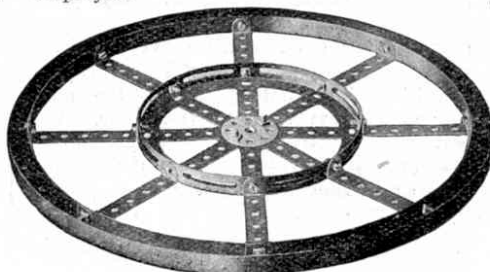

Example of how the new Meccano parts, Nos. 118 and 119, may be used together

First of all, No. 19c, the 6" Pulley Wheel, was illustrated in the February Magazine, and is a part that has long been needed. It is the largest of its kind made, and has a boss and set-screw with which it may be secured to an axle rod. This part is invaluable in models where a smaller sized pulley is unsuitable. Two of its most useful applications that occur to me are as a reduction or step-up drive, and, when used in conjunction with the Large Wheel Hub, as a large ball race.

No. 118, Large Wheel Hub, is made in one size only, namely, 5½" in diameter. It may be used for various purposes, such as, for example, a small fly-wheel. The equidistant holes in the spokes and outer rim make it possible to build it into a model, and so use it in many ways. By attaching Rack Segments to it, it may be used as a base for rotating cranes, etc. When used in conjunction with part No. 119, the Large Wheel Segment, an 11½" diameter wheel may be constructed, as illustrated on this page. Eight Wheel Segments are required

to form the wheel rim, and, with the Wheel Hub as a centre, 2½" x ½" Double Angle Strips radiate to the outer circumference. The large wheel thus obtained may be used in several models, such as a large fly-wheel in the Beam Engine. The Large Wheel Segment may also be used for forming a wheel race, used in the base of large Cranes, Excavators, etc.

I think that No. 130, Triple-Throw Eccentric, is one of the most useful of all Meccano parts. Its use is illustrated in several models in the Manuals. One of



No. 134. Crank Shaft

its many applications was given last month in the description of the model Cake-Walk. The Triple-Throw Eccentric embodies a very ingenious and thoroughly sound mechanical principle, and is chiefly used to convert a circular motion into a to-and-fro or up-and-down movement, as in the Cake-Walk model already mentioned. Three different degrees of throw are obtainable (i.e., 1", ¾" and ½") by altering the position of the rod in the boss and set-screw, according to the degree required.

No. 134, Crank Shaft, in the system has a 1" stroke, and was introduced last year to fill an insistent demand. Now-a-days we can scarcely imagine the Meccano system without a Crank Shaft, and we wonder how we overcame the difficulty before this part was added to the system. It has a variety of uses, which are too obvious to need description. Last time I visited the Meccano factory I saw that the model-building department were busy experimenting with a new form of crank—a double crank, in fact, with a special coupling for a big-end connection. This part has not yet been adopted, but may be introduced at some future date.

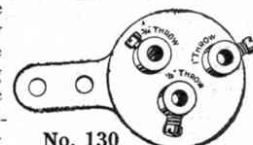

No. 130
Triple-Throw Eccentric

No. 137, Wheel Flange, is particularly useful in making the "race" for ball bearings, as described in the February "M.M." It is fitted inside a 3" pulley wheel, and both are mounted on a common axle, the balls being placed between the two flanges. When used in conjunction with a Face Plate, the Wheel Flange gives a Flanged Wheel of 2½" diameter.

In a recent number of the "M.M." full instructions for building the Meccano Motor Chassis were given. In the original model, some ingenuity had to be exercised in making a universal joint (to connect the Large Wheel Hub gear box and cardan-



No. 118
Large Wheel Hub gear box and cardan-

(Continued on page 103)

ELECTRICITY

*A series of Splendid Articles
specially written for Meccano Boys*

II. FURTHER EXPERIMENTS WITH STATIC ELECTRICITY

IN our article last month we showed how a glass rod that is electrically charged (by rubbing it with a silk handkerchief or piece of flannel) attracts or repels pith balls. We mentioned also that electricity is of two kinds, "negative" and "positive," and that the kind of electricity with which a glass rod becomes charged depends upon the material used for rubbing it. Glass rubbed with silk takes a positive charge; sealing-wax rubbed with flannel takes a negative charge.



Fig. 5

We may demonstrate this more clearly by suspending a glass rod in place of the pith ball. This may be done by arranging two loops of silk thread, or by hanging a stirrup of wire by a silk thread from our support. Before suspending the rod in this manner we first electrify it by rubbing briskly with a piece of flannel. Then, by slipping it through the loops, we leave it hanging in a charged state. We then charge another glass rod in a similar manner, and on holding it near the suspended rod we find that the latter is repelled by it (Fig. 5). On the other hand, if the rod we hold is charged by rubbing it with a silk handkerchief, we find that it does not repel the hanging glass rod, but attracts it (Fig. 6). When performing this experiment remember that the hanging rod should be recharged, if the other rod touches it at any time.

Curious Behaviour of Pith Balls

The same experiment may be repeated with two pieces of sealing-wax, in place of the glass rods, rubbing them with a silk handkerchief, a piece of fur, or with flannel. Many other interesting experiments on similar lines may be devised. For instance, having observed the effect on the pith balls, first of the glass rod and then of the sealing wax, we may learn what happens when the glass and sealing-wax are used together. Having first presented the sealing-wax—excited with flannel—to the balls, rub the glass rod with the silk handkerchief and hold it near to the balls. They will at once be attracted by it, although

they had been previously repelled by the sealing-wax. Allow the glass rod to touch them until they become fully charged and they will then be repelled by it. On presenting the excited sealing-wax to them again, however, they will now be attracted by it.

Electricity, the greatest force in the Universe, is a good servant but a bad master. When imprisoned and under control it serves man, giving light and power. Unfettered—as in the lightning flash—it may do great damage, setting fire to a warehouse or wrecking a building.

Attraction and Repulsion

Another extension of the original experiment may be performed by using two pairs of pith balls, suspending them by silk threads from separate supports. Hang each pair some distance apart and, rubbing the glass rod with the silk handkerchief, electrify one pair. Now rub the sealing wax and electrify the other pair, having done which move the two pairs near each other. A surprising condition immediately arises, for one pair will be attracted by the other. All trace of electrification will promptly disappear if they are allowed to touch.

From these experiments we prove to our own satisfaction that there are two kinds of static electricity, as Dufay discovered. We also see that unelectrified bodies are strongly attracted by either kind of electricity, whether + or -. At the same time we learn that two bodies charged with the same kind of electricity, no matter whether positive or

negative, repel each other. Having thus mastered the meaning of positive and negative electricity, we shall have less difficulty in understanding and making other experiments of a more advanced nature, later on.

Electrified Paper

We may generate static electricity by several methods other than by rubbing with silk or flannel. For example, a piece of writing paper warmed before the fire, laid on a wooden table, and rubbed briskly with a dry hand adheres to the table (Fig. 8).

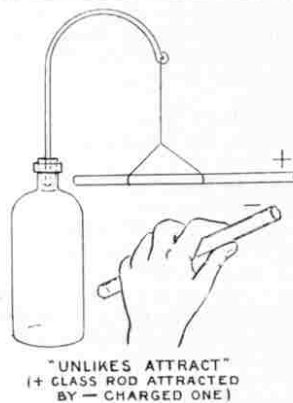

Fig. 6

Ordinarily the paper is easily moved about on the surface of the table, but after being rubbed it is difficult to move. If one corner be lifted, the paper will curl up and will cling to the hands or clothing. If held to the face a tickling sensation is experienced.

Those of my readers who are photographers will, perhaps, have experienced a similar phenomenon when drying their prints. In order to obtain a high glaze, photographic prints are pressed with a rubber roller (known as a "squeegee") on to a metal plate. After having been dried by the fire the corners of the prints are lifted and the dried prints peel off the plates. Often they will be found to be electrically charged and adhere to the plate, to the hand of the photographer, or to any portion of his clothing on which they may be placed. If they are lifted to the face there is a tickling sensation as though a very feeble electric current is passing.

All these phenomena are due to the fact that in each case the paper is electrified with a charge of static electricity. In obedience to the law mentioned in our last instalment ("unlikes attract") the paper adheres to other objects because they are not electrically charged.

Constructing an Electroscope

The presence of a charge of electricity is demonstrated by an electroscope, a simple form of which may be made as indicated in our illustration (Fig. 9). This consists of a fold of paper balanced on the point of a needle, the head of which is embedded in a cork.

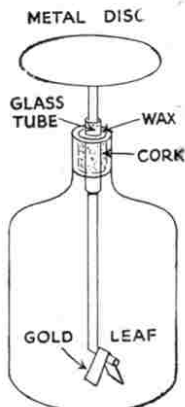

Fig. 7
A Simple Electroscope

Take "Snaps" like this!



By a Little Nipper Club Member

WITH A

LITTLE NIPPER

PRICE COMPLETE: **5/6** PLATES 6d. PER PACKET OF SIX.

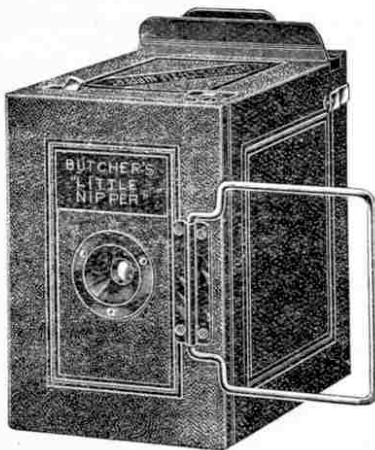

Every Boy and Girl who buys a LITTLE NIPPER gets FREE:—Membership of "The Little Nipper Club." "The Little Nipper Times," Monthly. Advice and Prize Competitions in which all have an equal chance.

OF ALL CHEMISTS AND PHOTO DEALERS.

Write for Leaflet MLN—it's free.

W. BUTCHER & SONS LTD.,
Camera House, Farringdon Avenue,
LONDON, E.C. 4.

Electricity—(cont.)

Actually this simple electroscope is a kind of paper compass, and it will move around when the charged glass rod is brought near it, just as a compass needle will move when a bar-magnet is brought near it.

Another form of electroscope, which is sensitive to less powerful electrical charges, may be made from gold-leaf, which may be obtained from a picture-



Fig. 8. Experiment with Paper

framer or artist's colourman. If gold-leaf cannot be obtained, very fine tissue paper will serve the purpose, but is not so sensitive. First obtain a glass jar with a wide neck, and then hang the strips of gold-leaf from a piece of wire passed through the neck of the bottle. The gold leaf is suspended by bending the lower end of the wire at right-angles as shown in our illustration (Fig. 7). The bottle is closed by a cork through the centre of which a narrow glass tube passes. The glass tube is used to completely insulate the wire and an additional precaution may be taken by coating the cork with wax to insulate it more completely from the bottle. A metal disc of two or three inches in diameter is soldered to the upper end of the copper wire and the electroscope is ready for work.

If we bring an electrified glass rod to the metal disc of the electroscope we find that the strips of gold-leaf repel each other in a marked degree. If the electroscope has been well made, the gold-leaf will begin to separate even whilst the charged rod is some distance from the disc. The gold-leaf electroscope is one of the most sensitive means of detecting small charges of electricity and has been used in most of the important electrical experiments by leading scientists. This form of electroscope may be made so sensitive that the strips may be caused to diverge simply by the electrical charges generated in the chips formed by sharpening a pencil.

A Surprise for the Cat

Summer is not the best time for performing experiments with static electricity. These are more successful when the air is cool and clear. In summer the atmosphere contains a large proportion of moisture, and this conducts the electricity away from the apparatus almost as quickly as it is produced.

An interesting experiment in static electricity may be performed with your cat on a cold, dry day in winter. Choose a time when the cat is near a fire and stroke it rapidly with the hand. If you listen carefully you will notice a faint crackling noise as your hand passes over the cat's

fur. If you perform this experiment in a dark room you will be able to see small sparks passing between your hand and the cat, and it is these sparks that cause the crackling noise. After you have been stroking the cat for a short time, place your knuckle near the cat's nose. A spark will then jump from the cat to your knuckle (Fig. 10), much to the surprise of the cat, who will probably not be at all pleased with your experiment! The experiment is an interesting one, but we hope that—for the cat's sake at any rate—our readers will not perform it on more than one occasion, even if they are able to persuade pussy to come along and oblige them a second time!

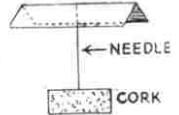

Fig. 9

Electrified Sand

Before concluding this article we may mention another exceedingly interesting experiment, which illustrates the mutual repulsion of bodies charged with the same kind of electricity. If we pour fine, dry sand into a funnel, the sand runs through the funnel in a steady narrow stream. Now let us connect the reservoir of the funnel by means of a wire to a glass rod, which may be conveniently electrified by rubbing with flannel. If now the funnel be filled with sand, and the rod electrified, it will be seen that, at each stroke of the flannel on the rod, the sand stream breaks and the particles fall, not in a narrow stream, but in a wide one, something like an open umbrella in shape. The explanation of this is that the tiny particles of sand, all being charged with the same kind of electricity, repel one another, and in their efforts to get away from one another they spread out into a wide stream.

NEXT MONTH

In our next issue we shall tell how Franklin brought an electric current from the sky to earth by means of a kite. We shall also describe an interesting experiment called "the jumping frogs."

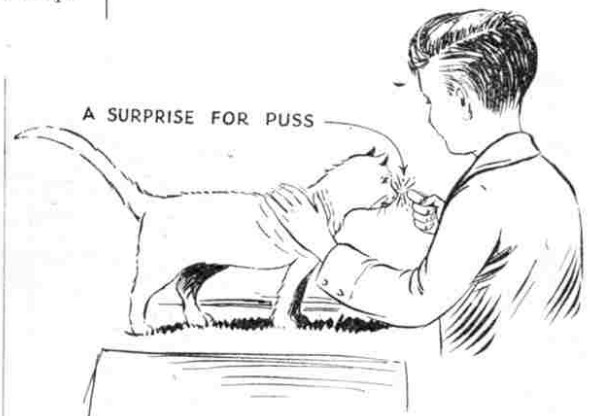

Fig. 10
Making a spark between the cat and your knuckle

Millions of Underground Travellers

WONDERS OF LONDON'S TUBE RAILWAY



WHEN a boy, one of my greatest ambitions was to visit London, and I suppose that a large number of my readers are filled with a similar ambition—except those who live in or near London and to whom a visit to the great City is no novelty.

London has a long list of interesting objects and wonderful sights that attract all visitors. Westminster Abbey, the Zoo, Kew Gardens, the British Museum, and the Horse Guards, the National Gallery, the Tower, Greenwich Observatory, and hundreds of other wonders too numerous to mention, make their appeal.

In visiting these objects of interest widely scattered over a large area, the visitor is certain to use the Underground Railways. A journey on the Underground is most interesting, and as there are very few such railways in existence the experience may be called an unusual one.

Apart altogether from the cutting and construction of the tunnels, which was itself a wonderful engineering achievement, the Underground is a triumph of organisation and good management. Here are to be found all manner of labour-saving devices and precautions for safety, embodying some of the cleverest inventions imaginable.

"Safety First"

From the time of the early workmen's trains to the after-midnight theatre service, a long succession of underground trains is run throughout the day. In the busiest times—when the city workers pour into the city in the morning, and when they rush home in the early evening—as many as forty trains may pass each station in an hour. The trains travel rapidly, and as they stop for even less than a minute at the stations there is no time wasted! Passengers quickly alight and others board the trains, urged by the officials' "Hurry up, please." All is

bustle and excitement, yet it is an orderly speeding-up, which is very different from an excited and disorderly crowd. Because of the splendid organisation, accidents are of very rare occurrence, either on the platforms or on the lines.

Travelling in Comfort

Those who have read of some of the difficulties and discomforts experienced by workers in a coal mine might imagine that travelling several hundred feet beneath the ground would be an unpleasant experience. Such is not so in the case of the London Underground, however, for everything is done to make passengers as comfortable as possible. On entering a station they are taken down to the level of the railway by commodious lifts. Where the lifts are situated a short distance from the platform, the walk is along passages lined with white glazed bricks, and brightened by the addition of numerous posters, tastefully reproduced in colour. Indeed, all passages and stations are brightly lighted by electricity, and the air is always fresh and sweet being kept in constant circulation by a special ventilating system.

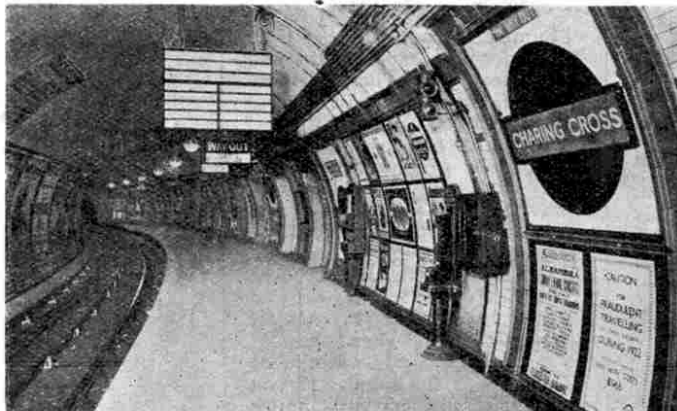

Charing Cross Station on the Underground

The trains run in circular tunnels, lined with metal rings rivetted together. The tunnels are therefore really huge steel tubes through the ground beneath London, and from this fact the Underground obtains its more familiar name of "Tube." Each tube accommodates a single line of rails, and in order to eliminate danger as much as possible, the trains run in one direction only.

The Greathead Shield: A Wonderful Invention

The boring of the tunnels was made possible by the Greathead Shield, an invention that has greatly simplified tunnelling. This device consists of a powerful steel plate, of the same diameter as that of which the tunnel is required. It is fitted with a cutting edge to pierce and break down the rock and soil that it encounters. The shield is driven by a number of hydraulic rams, and as it moves forward a ring of iron is built into position immediately behind it. In the accompanying illustration we see workmen setting one of these rings in position. At the same time the earth from the working-face is removed by a rotary excavator. With these two appliances, the shield and the excavator, a tunnel may be driven 20 to 25 ft. or even more, in a day.

Working in Compressed Air

Tunnelling under London is more difficult than tunnelling in other circumstances, however, and the obstacles encountered are even more numerous. For instance, a stratum of water-bearing gravel and clay may be struck, in which case the work must be carried on in a special chamber. In order to keep out the water the air must here be under pressure that varies from 25 to 41 lbs. per square inch, as against 16 lbs. normal pressure. Because of this, only men of exceptional physique are employed in this work. Even those

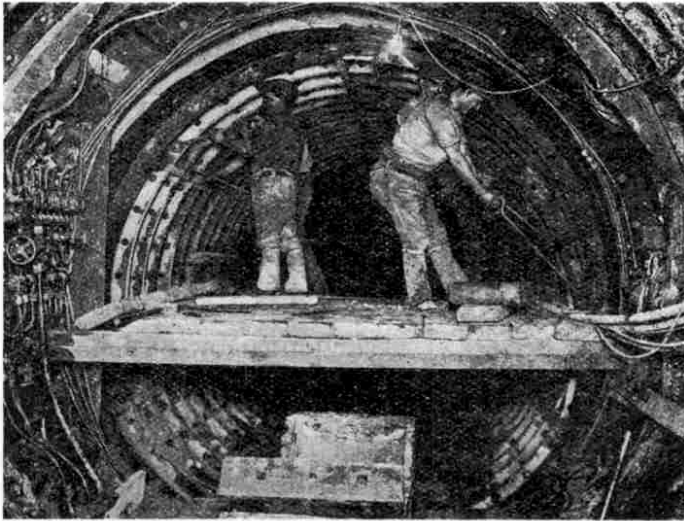

The Greathead Shield

men must pass through an intermediate pressure-chamber before entering the compressed air. Thus they encounter the full pressure only by degrees, as otherwise bleeding at the nose and ears would occur.

Having closed the outer door of the air-lock, the air is allowed into the inner chamber through a valve, and the inner door is then opened, the men stepping into the compressed air.

Trains Run 21 Hours Each Day

Even when the construction of the Tube is completed there is a considerable amount of reconstruction and repair work necessary to keep the permanent way in order.

As the trains are running continuously all day, these repairs have to be carried out at night, during the time when the traffic has stopped. As the trains only cease to run at 1-15 a.m., and as the next trains commence at 4-45 a.m., all necessary work must be done in these 3½ hours respite. The track, the signalling, the lighting installation, the power plant, and the hundred and one other details, must be attended to.

In our illustration is seen the permanent-way gang at work on their nightly task, after the trains have ceased to run.

A Machine that is Almost Human

Of the many ingenious devices for time and labour-saving to be found in the Tube, one of the most wonderful is the Passimeter. This mechanical apparatus combines the duties of booking-clerk, barrier-attendant, and ticket-inspector. Here a ticket is issued mechanically to the intending passenger, and after it has been snipped by the machine, the passenger is allowed to pass through the barrier. His passage is recorded by a kind of cyclometer, which counts the number of passengers and records them as required. The Passimeter eliminates the necessity for employing several men, who would be otherwise necessary.

Another wonderful device is the Escalator, or moving staircase, fitted at several stations, notably Earl's Court. On page 103 is shown one of these moving stairways with the steps on the left-hand stairway removed, disclosing the mechanism beneath. The stairway on the right brings passengers down to the station, and that on the left takes passengers up to the road level.

How the Moving Staircase Works

Leaving the trains, and wishing to ascend to the road level, the passenger finds that a part of the floor in front of him is moving. He notices that when any particular section of the floor approaches the incline, it forms itself

into a series of steps, all of which move upward at the rate of five miles an hour.

At each side of the steps is a hand-rail moving at the same speed as the steps. By stepping on to the moving floor and taking hold of the hand-rail, the passenger is carried upwards to the road level, without the exertion of having to climb hundreds of steps. If he is in a particular hurry, however, he may leave his original step and walk up the staircase, as well as being carried with it. By so doing, he arrives at the top sooner than if he had maintained his position on the original step.

Only One Journey Allowed!

At the top, the steps again flatten themselves out and form a floor that is continually moving forward. The passenger steps off this moving floor on to the ground, and so gains the street.

Travelling on a moving staircase is great fun, but the officials are particularly watchful that Meccano boys do not spend a happy two or three hours, travelling up one staircase and down the other! If you visit the Tube you must be content with a single trip only, up or down the staircase, on each occasion that you enter the station.

A Complete System that Links Up all London

The illustrations on these pages are from photographs taken on the underground system known to Londoners as the Hampstead and Highgate Tube. There are also other London systems,

however, including the Bakerloo Tube, the Metropolitan Railway, the Central London and the District Railway. These systems link up all London and its many suburbs on either side of the Thames. If it were possible for us to obtain an X-ray view of the ground beneath London, we should find these tube railway tunnels under the great city, like rabbit warrens, and forming a series of tunnels quite distinct from the enormous number of subways, cellars, sewers, and gas and water mains.

The track of the District Railway runs both underground and on the surface. Part of the underground portion, known as the Inner Circle, embraces nearly all the important stations in London, both in the East and West and in the City. This is a circular track with no terminals, the trains continuing to follow each other around

the circle at intervals of only a few minutes. The drivers and conductors are relieved when necessary at certain specified stations.

(To be continued)



A Gang at Work on the Permanent Way

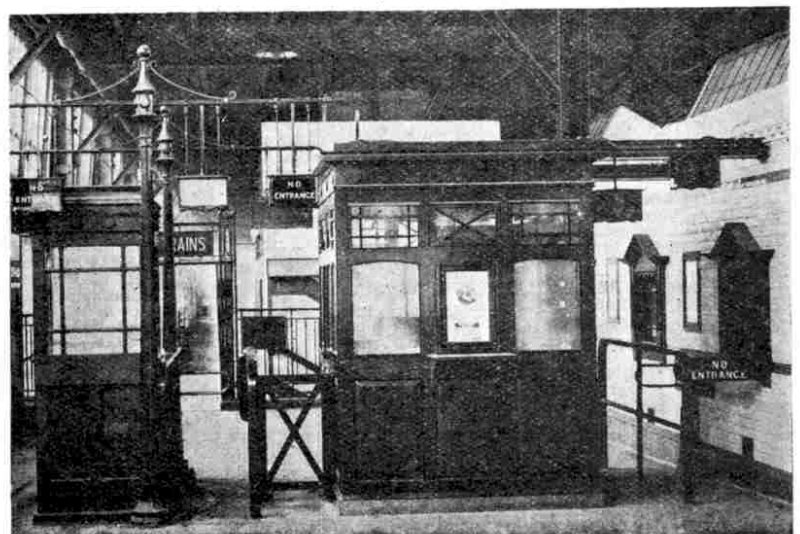

The Passimeter—a Wonderful Labour-saving Machine

Stamps for Sale

(For Advertisement Rates see page 112).

100 BRITISH COLONIALS including Dollar, Rupee and Shilling Values, 3/-, Post Free. H. Theobald, 54, Antill Road, London, N.15.

STAMP COLLECTORS! Be sure you get *The Philatelic Magazine*, the fortnightly stamp newspaper, 3d. from any newsagent, or 4d. post free from Publisher, 63, Windsor House, Westminster, S.W.1.

SIXTY DIFFERENT STAMPS FREE to applicants for approvals; all ½d. each; send postage.—Cox, 135, Cambridge Road, Seven Kings.

5/- K.E. TRANSVAAL 1/- to applicants for Approvals, Sets, Packets, etc. William Stamp Co., 180, Bishopsgate, London.

FREE. Harding Memorial Stamp and Pictorial Set, with approvals, from 6 a penny. Send postage. Powell, 73, Bond Road, Surbiton, Surrey.

SET OF 10 HYDERABAD FREE to appro. applicants. Try my ½d. Booklets. S. Huckle, 53, Birkenhead Avenue, Kingston-on-Thames.

ECUADOR TRIANGLE FREE, with approvals, ½d. and 1d. each. Bodman, 6, Alderman Road, Ipswich.

WONDERFUL BARGAINS.—100 Colonials or 100 Foreign Stamps, all different. Sixpenny postal order and twopenny.—Scott, 154, Wellesley Road, Ilford.

LOOK, BOYS! GRAND PACKET. Pictorials given away to applicants for approvals. Send postcard to-day. L. C. Jones, 13, North Road, Bourne, Lincs.

FREE. 20 Austria, unused, 6 Hungary to approval applicants.—Harland, 47, Dean Road, Scarborough.

FREE—FROM GIBBONS

New Illustrated Lists of Albums, Packets and Sets for 1924 free on request, from the largest firm of stamp dealers in the world. Nowhere else can you get such bargains.

See our up-to-date Improved Album at 2/-. Other albums from 5/- to 40/-, including magnificent **British Empire Album** just published. Packets and Sets from 6d.

Stanley Gibbons Ltd.
391, Strand, London, W.C.2.

STAMPS FREE Applicants for approvals sending postage receive either A COMPLETE SHEET OF 100 unused or 26 different unused, Peace, War, Air Post, etc. 60 page List profusely illustrated, 1d. only.
M. C. WATKINS, Stamp Importer, BARNET.

NORRISCO BARGAINS
200 different GERMANY
Only 1s. 6d. Postage extra.

Here is an exceptionally fine long set, and every Collector would be well advised to purchase at once as the supply of cheap German stamps is diminishing rapidly now that a Gold Currency has been adopted. **SATISFACTION GUARANTEED ON ALL OUR GOODS OR CASH REFUNDED.**

Other Long Set Bargains:—
40 Brazil, fine set 1/- 75 Jugo-Slavia (cat. 23/-) ... 3/3
75 Chile (cat. 24/-) 6/9
40 Esthonia, nearly complete ... 5/6
50 Fiume (cat. £3) 6/- 30 Luxembourg, nice set 1/6
30 Turkish War Stamps 3/3

FULL LISTS FREE. COLLECTIONS OF ALL COUNTRIES AT ½ to ¼ Cat. value.

NORRIS & CO. (Dept. M.M.), LEABROOKS, ALFRETTON, Derbyshire, England.

12/- WORTH CHOICE STAMPS FOR 3d.

Packet No. M.B. contains following mint stamps:—
CEYLON, 1 on 5 and War; pr. rare UKRAINE, cat. 7/6; 2 Jugo-Slavia; Magyar, 3k.; set 3 Turkey; 2 Schleswig; fine set 10 BELGIUM, 1902, face 5 fr. 60; also 5 VENEZUELA, cat. 1/6. The lot 3d. Postage 1½d. Bargain

Nelson T. Hillier, The Stamp Mart, Horsmonden.

50 French Colonies	9d.	300 Postage	1/-
100 United States ...	1/-	600	5/-
150 Germany	1/-	500 Revenue	5/-
150 Austria ...	1/-	1000	17/6
150 Hungary	1/-	50 Cards &]	
		Envel. 1/-	
60 Czecho Slovakia	1/-	100	2/6
50 Roumania	1/-	150	4/-
50 Sweden ...	1/-	200	5/6
40 Italy ...	9d.	250	7/6
40 Belgium	1/-	300	10/-

Postage Extra.
Fine selections ready in separate countries.
J. Russell, Chetwynd, Shanklin Drive, Westcliff-on-Sea.

STAMPS—FREE PACKET

Cat. 3/- to all writing for my cheap approvals. Try my "Gem Packet" of 50 Stamps, 8d.; or Derby Packet of 100, 1/2. Stamp Mounts, 7d. 1000. Extra Special Peelable Mounts, neatly boxed, with Watermark Detector sunk into lid, 1/- 1000. All Post Free. Perforation Gauge or Packet of Mounts given with each packet of stamps. Try a packet, you will be surprised at the value.

STALEY, Chapel Street, CODNOR, Derbyshire.

225 DIFFERENT REVOLUTION WAR AND PEACE STAMPS FREE

This packet is printed and priced to sell at 10/- and contains many "hard to get" sets, high-class pictorials, and odd values, catalogued from 1d. to 7/6 each. Given free to all requesting approval books and sending 4½d. to cover cost of postage, packing, etc. (abroad 9d.).

R. WILKINSON,
Provincial Buildings, COLWYN BAY.

FREE To applicants for approvals. From ½d. upwards. 3d. off every 1/- worth purchased. Packet contains 20 Stamps Foreign and Colonial, including 1d. British Central Africa, 1901. None of the latest unused Europeans included.
Betts, 49, Durham Road, London, S.W.20.

SPECIAL BARGAINS FOR APRIL

All different; no duplicates; postage extra please. 250 Austria, 5/-; 150 Hungary, 2/-; 75 Bavaria, 9d.; 100 Danzig, 4/6; 108 Fr. Colon., 3/3; 38 Sweden, 8d.; 60 Roumania, 1/3; 20 Liechtenstein, 2d.; 225 Germany, 3/6; 100 New Russian States, 1/3; 16 Upper Silesia, 6d.; 90 Poland, 2/6; 100 U.S. America (many old), 4/-; 40 Japan, 1/6; 30 Jugo-Slavia, 1/3; 110 Portugal and Colonies, 7/6; 118 Central and S. America, 2/-; 35 Hong Kong and China surcharged, 2/6; 25 Kenya, Tanganyika and Zanzibar, 2/6; 35 Brazil, 1/9; 50 Argentine, 1/-; 75 Belgium, 1/3; 25 Ukraine, 6d. 25% reduction to readers of this paper. Send for my full list.
ERNEST HARROD, 110, Pepys Road, London, S.E.14.

FREE! 25 BULGARIA to those sending postage and asking to see Approval Sheets.—
C. FLORICK, 179, Asylum Road, London, S.E.15.

140 DIFFERENT STAMPS (Cat. 25/-) for 1/- Packet No. 052, contains 140 different stamps including 2 Batoum (British Occupation), 9 EPIRUS, FRENCH 5 fc. (Cat. 2/-), 9 unused POLAND, 25 to 2000 mks.; obsolete Danzig, 100,000,000 mks.; and set of 18 GERMAN PROVISIONALS unused. Only 1 packet sent to each applicant. Postage 1½d. extra. **GREAT FREE GIFT OFFER:** Every 50th applicant will receive gratis a Rare 10/- NORTH WEST PACIFIC Is. (Cat. £1).
BRIGHT & SON, 164, Strand, London, W.C.2.

FREE GREAT BRITAIN Id. lilac 1881. The rare 14 dot variety (cat. 2/-) to all applicants enclosing 3d. for copy of our latest 50-page Price List of Stamps, Albums and Accessories.—**THE MIDLAND STAMP CO. LTD.**, 78, Warwick St., Leamington Spa.

THE "DIAMOND" PACKET contains 1000 UNSORTED STAMPS from Convents abroad. 1/3 post free. 2 pkts., 2/5; 3 pkts., 3/6; 4 pkts., 4/6; 5 pkts., 5/6.
Nerush, Importer (Dept. E), 2-22, Cathcart Hill, London, N.19.

1000 MIXED STAMPS 1/-; 3,000 2/-—Cranwell, 55, Cowslip Road, London E.18.

12 SWEDEN GRATIS Good Copies Approvals. Postage 2d.—Noave, 25, Partwall Rd., Paddington, W.9.

7 COMPLETE SET 1c. to 100c.
presented EXTRA with every
Bolivia "ILIXUM" PACKET—3d.
150 picturesque varieties,
Gratis INCLUDING OVER 50 UNUSED

Triangular Fiume, Paraguay, Ivory Coast, Azores, Bosnia, Bulgaria, Malta, Jugo Slavia, Colombia, Gabon, Jamaica, Dahomey, Poland, Morocco, China, Philippines, Hyderabad, St. Pierre, Transvaal, Ukraine, Cape Colony, Mozambique, San Marino, Monaco, etc. Entire Collection for 3d.
Only one packet allowed to each customer.

SEE our PRICE LIST for Bargains in Albums, Sets and Packets.
Errington & Martin, London, E. 9

BRITISH EMPIRE
AUSTRALIA, Kangaroo, Set of three used ... 1½d.
BRITISH GUIANA, 1907/10, Set of two used ... 1d.
CAPE OF GOOD HOPE, 1884/1902, Set of three used ... 2d.
JAMAICA, 1½d. War stamp, used ... 1d.
NIGERIA, K.G. old wmk., 1d. carmine, used ... ½d.
TWEEDERS, best quality, nickel plated, milled sides ... 1/-
ASK FOR MY NEW PRICE LIST.
ALEC KRISTICH (N.R.P. 279), 82, Marchmont Street, Russell Square, London, W.C.1.

ICELAND TO IRAQ, VIA IRELAND. A Grand Tour in Philately. Bijou Collection, containing 29 diff. valuable stamps of these countries for 2/-. Bonus, 1½d. mint Dominica War Stamp. Atlas Album, a beauty, 8/3. Martin, 68, Whetley Hill, Bradford, Yorks.

Free to Applicants for Approvals.
SET LARGE PICT. FRENCH MOROCCO
One of the most beautiful sets ever issued, depicting The Temple at Rabat and Castle Gate at Fez.
Or any one of the following:—
7 Pictorial Turkey. 5 Sonora (cat. 2/3).
4 French India (surch.) 15 Pict. Edeburg.
5 Memel on France. 16 White Russia (cat. 3/4).
Ask for particulars of how to increase your collection for nothing.

ALBAN SIMMONS, HILLSIDE, NEW BARNET.

SPECIAL OFFER TO MECCANO READERS ONLY
A fine packet of stamps including British Colonials, or post-cards (stamp view side) will be sent free to applicants enclosing 3d. for particulars of the British Correspondence Club.

This Club has nearly 3,000 members in all parts of the world, including Ceylon, China, Iraq, Japan, Palestine, Belgian Congo and Mozambique, who send stamps, post-cards and curios in exchange for those of your country. Write now to:—
H. J. Hopkins, Dept. M., 8, Sparkenhoe Street, Leicester, England.

STAMPS

500 diff., Egypt, Sudan, Syria, Palestine, Arabia, Iraq, Transf., Abyss., Alex., Port Said, Brit., French and Portug. Africa. Value £4. Only 10/-, post free reg.

PAUL VINCENT,
General Delivery, CAIRO (Egypt).

'ASIA' PACKET—FREE

25 selected issues including PERSIA (scarce Provisional), GWALIOR, Travancore, Ceylon, China (Ship), Deccan, Malay (Tiger), Patiala, Siam, Straits, etc. Ask for APPROVAL SHEETS and receive this fine packet FREE! Enclose 1½d. postage.

FELIX SYKES, Stamp Importer, NEW BARNET.

MECCANO STAMP COLLECTORS!!!

20 Chili, 5d.; 20 Cuba, 5d.; 30 Danzig, 3d.; 100 Germany, 3d.; 50 Hungary, 2d.; 40 Italy (Cat. 3/10), 5d.; 25 Roumania, 3d. All diff. Postage extra, only to Readers enclosing 4d. extra for the First Number of "THE BOYS' NOVEL STAMP PAPER," 1924 Price List, and "Select" Bargain Approvals.
THE WESTERN IMPERIAL STAMP CO.,
46, Drynham Road, Trowbridge, Wilts.

NOT a Sensational Bargain, but a real good chance. To all who buy to the value of 1/6 or more from my approvals (and they are real value for money) I will send a mint set of 3 cat. 3/-. Other gifts in proportion. Write NOW for a selection, and SEND POSTAGE. CAN YOU BEAT THIS? Germany Set of 15 long numerals to 100,000 M.—9d. Worth 2/- and catalogued much more. Bavaria, 1920 opt. "Deutches Reich." 10 and 20 M., cat. 6/6—1/-.
List of other lines on request.

P. A. Westbrook, St. Benet's, Westgate-on-Sea.



SPECIAL ARTICLE II.

JAMAICA.

THE FAMOUS LLANDOVERY FALLS.

Imperial Penny Postage, or penny postage from and to anywhere in the British Empire, was introduced by Canada at Christmas, 1898, and was followed by Jamaica on May 24, 1899. Foreseeing that this departure would cause a great increase in the bulk of her Colonial correspondence, Jamaica seized the opportunity to introduce the beauties of her island to the British beyond her coasts by issuing (on May 1, 1900) her first picture stamp.



This stamp, a view of Llandoverly Falls, was larger than the regular size, and was first issued in an all-red colour. Although the colour was perhaps quite British, the stamp printed thus was hopeless as a work of art. Later (September 25, 1901) the stamp was printed in two colours, the centre or view in black, and the border in red, giving a more artistic result.

It has been claimed that the view depicted on this stamp is Welsh scenery, but in reality it was copied from one of a series of photographs sold by the local tradesmen, the Falls being situated in the district of St. Ann, Jamaica.

Keen observers have pointed out that just above the *RY* of LLANDOVERY is a rock that appears as the figure of a man. This has been stated to be Sir Henry Blake, Governor-General of the island at the time the photograph of the Falls was taken. Dr. James Johnson, who was the photographer of the picture, states that no one was there at the time and that the supposed man is but a rock projecting from the water!

The official figures state that 92,918 stamps were printed in the all-red colour, in two printings dated July 1900, and February 1901, respectively. This gives the date of the first printing as being later than when the stamps were actually issued (May 1, 1900), so that it would seem that there was another printing prior to those given by the officials. The figures for the black-and-red stamp are given as being 261,924 stamps, in six printings, the last being dated November 27, 1903.

R.K.G.

ESSAY COMPETITION

The attention of Overseas Stamp Collectors is drawn to the Essay Competition, particulars of which appear on page 111.

Papers and How to Identify Them

A STUDY of the various kinds of paper on which postage stamps are printed is interesting, and often the knowledge thus gained is a valuable acquisition. As in the case of watermarks, a particular variety of paper may change the value of a stamp from pence to pounds.

Stamp papers may be divided roughly into two classes:—(1) General, and (2) Special. The former class, which includes those papers used by many stamp issuing countries, is commoner than the latter class, which has been used only on one or two occasions in order to meet some special requirement.

"General" Papers

Blued paper, which is sometimes described by the French word *bleuté*, is a paper that has accidentally been turned bluish, either in its manufacture or by the ink with which the stamp has been printed. The imperforate penny red of Great Britain, issued in 1841, is printed on blued paper.

Chalk-surfaced (or *chalky*) paper is a term incorrectly used to denote *coated* paper. This is paper that, although quite normal paper in all other respects, has a chalky surface. The chalky surface makes it impossible to remove the postmark on a used stamp without also removing the design of the stamp itself. Many King Edward stamps of Great Britain are printed on this paper, and about half the current British Colonial stamps. The test for a coated paper is to pass the milled edge of a silver coin across the stamp. If the paper is coated a thin line, somewhat similar to a pencil line, will appear; if the paper is not coated no line will show. If it is not desired to keep the stamp the simplest test is to boil it, for if the paper is coated there will be no trace of the design after a few moments.

Granite paper contains a multitude of coloured fibres, and was used for the 1881-2 and following issues of Switzerland. It

RECENT ISSUES

HOLLAND. SILVER JUBILEE ISSUE.



Issued on August 31, 1923, to commemorate the Silver Jubilee of Queen Wilhelmina's reign, this stamp was designed by W. van Konijnenburg and J. van Krimpen, and printed by J. Enschede & Sons, Haarlem, the world-famous stamp printers. Four values were issued in the type illustrated and seven other values were

also issued in another type. As a stamp the design is not very attractive for it reminds one rather of a "cubist" picture, and as a "picture" of the Queen it is hopeless and is easily outdistanced by the handsome portrait issued on the same occasion by several of the Dutch colonies.



was also used for the 1894 issues of Serbia, although these issues have also appeared on ordinary paper. The stamps of Austria in 1890 also appeared on granite paper only.

Laid paper is watermarked with a series of parallel lines close together. These lines are caused by the impression of the wires forming the tray on which the moist pulp is laid (hence the name) during one stage of its manufacture. There are many stamps printed on this paper, one example being Serbia 1905. (Compare this paper with *bâtonné* paper described below).

Palure paper is about the thickness of tissue paper but considerably stronger and harder, and usually has a greyish tint. Good stamp mounts are made of this paper.

Quadrillé paper is watermarked with crossed lines forming squares or rectangles. The 1892 issue of the 15c. of France was printed on this paper.

Wove paper is of plain, even texture, and is most commonly used for books and newspapers. The "*M.M.*" is printed on wove paper, which is used for the present stamps of Great Britain, as well as the majority of other stamps.

"Special" Papers

Special papers are only used for one or two stamp issues. There is, for example, the *Basted Mills* paper, made by the Basted Paper Company and used for the December 1901 issue of New Zealand. This paper is thin, hard, closely wove, and watermarked with a double-lined "*N Z*" and Star. The previous issue of New Zealand (February 1901) with the same watermark, is on *Waterlow* paper, supplied by Messrs. Waterlow and Sons, of London. This paper is thick and soft. *Cowan* paper was also used for New Zealand stamps (May 1902), and was supplied by Messrs. Cowan and Sons. It is thin wove, and when without watermark is difficult to distinguish from other thin papers.

Bâtonné paper has thick watermark lines wide apart, the paper between the lines being either plain wove or laid. This paper should be carefully distinguished from laid paper, which has been described above. Examples of both kinds of *bâtonné* papers may be found in the official (black) stamps of Poonch, an Indian Native State.

Dickinson paper, named after its inventor, was used for the 10d. and 1/- embossed stamps of Great Britain and for the early issues of Bavaria, Schleswig-Holstein, Switzerland and Wurtemberg. Continuous threads of silk are embedded in it during its manufacture. These threads perform the same purpose as a watermark and prevent forgery owing to the difficulty of reproduction.

Gold-beater's skin. This is a transparent tough paper that, incidentally, is incorrectly named. On the back of this paper were printed the 10 and 30 sgr. of Prussia issued in 1866.

NEXT MONTH.

SOME INTERESTING WATERMARKS



The Meccano Double Headphones are British-made and of the highest quality procurable. They give loud, clear, undistorted reception, and will add greatly to the efficiency of any receiver. Comfortable to wear and easily adjusted. 4,000 ohms resistance. PRICE (post free), 15/6. Meccano Ltd., Binns Road, Liverpool

LISTEN WITH MECCANO RECEIVER No. 1

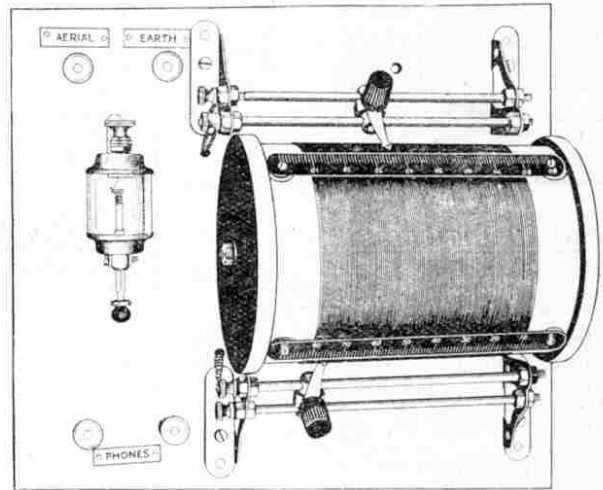

The Meccano No. 1 Receiver is a highly efficient and splendidly finished instrument. The crystal detector is exceptionally sensitive and is enclosed in a glass chamber. Two slides are provided, one on each side of the inductance, giving greater selectivity and clearness of reception. Wave length: zero to 1,000 metres. Dimensions of Set: 9 3/4" x 8 1/4" x 5". PRICE, post free (as illustrated), 15/9. Meccano Ltd., Binns Road, Liverpool

WIRELESS BARGAINS

Undoubtedly, the Finest Bargain on this page is our

5/- CRYSTAL SET 5/-

Every set tested 28 miles from a B.B.C. Station. Comprising Detector with 3-screw Crystal Cup and Sensitive Crystal, Wound Inductance Coils, Terminals, all wiring done, only needs a screw-driver to finish. Mounted on base-board, 6" by 5". Mahogany finish.

THE H.S. RADIO CO.,
36, Willes Road, LEAMINGTON
Money returned if dissatisfied.

A CHEAP AMPLIFIER

For your Crystal Set, and fill the room with music. No VALVES, transformers, etc. Any Meccano boy can make the wonderful "Varex" amplifier, cheaply, from our full drawings, etc., and "Carbox" contact, 2/6.

D. & Co. (Lewisham). Letters to 6, Loampit Vale, S.E.13.

LOUD SPEAKER (Automatic Telephone Co.'s) 2000 ohms resistance, with leads. As new, 25/- Box 20, Meccano Magazine.

"CYMOSITE" CRYSTAL. Sensitive all over.

If you fit "Cymosite" to your Wireless Set you know you have done everything possible, as far as the crystal goes, to make your set into a dependable instrument. "Cymosite" is the most popular crystal on the market. No need to twiddle about with the cat's whisker. Just make a light contact with the special contact wire supplied, and you get signals straight away. Every box is guaranteed, and contains 3 or 4 large crystals and special cat's whisker. Send P.O. for 2/6 to A. HALL, 55, Durham Road, Low Fell, Gateshead, and make an end to your crystal worries.

Make Your Own WIRELESS SET

Headphones .. 12/6 to 25/-
4,000 ohms Postage 6d.

Aerial Wire Copper, 100 ft., 2/4
Money returned if not approved.

Full List of Parts and Crystal Outfits free for stamps.

C. LUCAS,
HOBBIES FAMOUS DEPOT,
35, Manchester St., LIVERPOOL

A LOUD SPEAKER FOR 7/6
AMAZING RESULTS. Postage 1/-.

Fit a Malone to your phone and you get results rivalling a **50/- LOUD SPEAKER**

FOR ONLY **7/6** Post 1/-

Sound British Make. Complete, strongly packed. Fitted in a second. Don't delay, send P.O. 8/6 at once and listen in comfort. Send Stamp for free descriptive pamphlet.

M MALONE & CO 7 HART STREET, MARK LANE, LONDON, E.C.3

STATIC-RSTER



BOYS! Guard your Sets against harmful atmospheric

Price 2/9

RADIO SPECIALITIES,

57a, Denbigh Street, Pimlico, S.W.1.
Phone—Victoria 6463. Generous Trade Terms

Support our Advertisers

It is hoped that every reader of the "M.M." will patronise those firms who advertise in our pages, and whenever possible will make his purchases from them. When ordering goods or requesting catalogues it will help considerably if readers will mention to the firms concerned that they saw the advertisement in the Meccano Magazine.

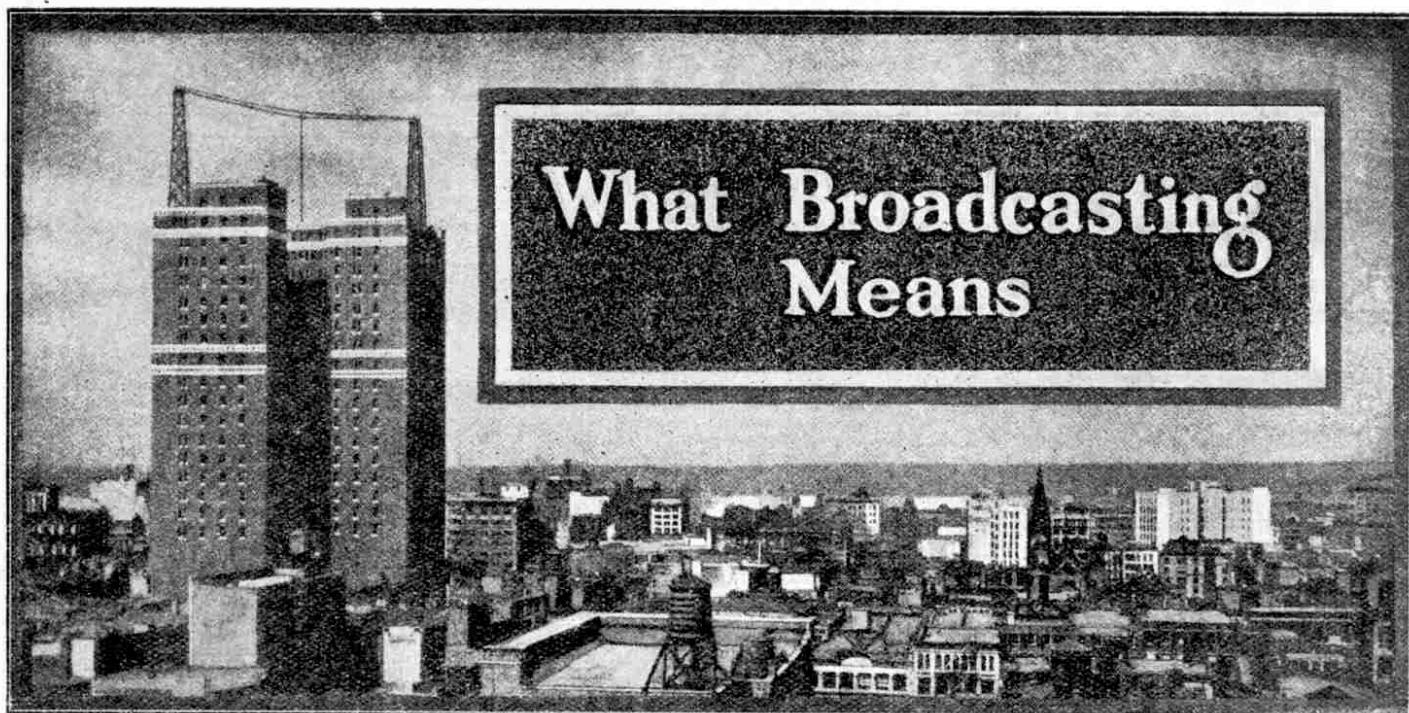

THREE or four years ago the word "broadcasting" might have applied to almost anything; to-day it has but one meaning, the sending out of programmes of music, lectures, news, etc., from certain wireless stations, to be received by all wireless receiving stations within range. One of the greatest charms of "listening-in" is that we do not have to leave our fire-side to go to concerts or lectures. Instead, the concerts and lectures come to us. But there is a danger that this easy method of obtaining an evening's pleasure may cause us to forget everything but our own little receiving apparatus, so that we fail to realise the tremendous amount of work that has to be done before the music or lecture reaches our ears.

Broadcasting Covers a Wide Area

Sitting in our own room listening-in, it is not easy for us to avoid the feeling that the music is being sent from the transmitting station straight to us, or at any rate in our direction only. But to appreciate the real wonder of wireless we must not forget that the music we are hearing is being heard also by listeners-in everywhere within working range of the station, no matter whether they live north, south, east or west of it. The electric waves, by means of which the music reaches us, are sent out from the transmitting station in every direction at once. Think of the surface of a pond and the ever-widening rings that spring into existence when a stone is thrown into it. Imagine the stone to be the broadcasting station, and the rings to be the electric waves, and you have a good illustration of what is taking place during the sending-out of a broadcasting programme.

Singing to an Unseen Audience

This is perhaps the most wonderful feature of broadcasting. A lecturer, standing before a microphone in a room at the broadcasting station, may talk to thousands

of people at once, no matter whether they live in towns or villages near or far from the broadcasting station. So, too, the efforts of a singer or an instrumentalist may be appreciated by this vast unseen audience.

It is rather interesting to compare the position of a singer at a broadcasting station with that of a singer at an ordinary concert. The latter has to face his audience and conquer his stage fright, but has the compensation of being in personal touch with his audience and of hearing

Broadcasting is the most wonderful development of radio telephony. It enables those who live in distant towns to listen to the finest music, which without broadcast would be available only to those living in our great cities. The most isolated farms and villages are now able to share in the entertainment of a great metropolis.

their applause after a song well sung. The singer at a broadcasting station has no stage fright to contend with, but has the uncanny experience of singing to an invisible audience, and of not having any indication as to whether he is succeeding or failing in his task. The singer has at any rate the advantage of personal security. One hears now and then of various unpleasant articles being thrown at singers whose efforts are not appreciated by their audience. But however much listeners-in may rage and storm at a particular broadcasting singer, they are quite helpless in the matter, and it is no use their thinking of expressing their disgust by hurling bad eggs or ancient cabbages at the artist!

At the Broadcasting Station

Day after day the great broadcasting stations of this country send out their programmes, and we may just take a "peep behind the scenes" and see what really is taking place. The artists engaged for that particular programme are gathered in a specially built room, thickly carpeted, and with walls, windows, doors and ceiling

heavily draped. A singer stands before a microphone, and the accompanist is seated at a grand piano, above the opened lid of which hangs another microphone, electrically connected to the first. Signals are exchanged with the room containing the transmitting apparatus, the transmitting switch is closed, the pianist commences the introductory bars of the accompaniment, and a moment later thousands of listeners-in are enjoying the song. The programme may also include

other singers, instrumentalists, an orchestra, lectures on various topics of general interest, items of the latest news of the day and results of football and other matches. As the programme continues, one's imagination roams away to the thousands of homes in which listeners of all ages are

enjoying a first-class entertainment brought to them by the unseen, silent, electric waves.

Securing Good Transmission

Now let us examine the broadcasting studio in more detail. First of all it may be wondered why the room is so heavily curtained everywhere. This is to ensure that only the pure tones of the singers or instrumentalists are transmitted. Without the drapery the musical sounds would be mixed with echoes from walls and ceiling, but such echoes are effectually muffled by the curtains. Again, we have spoken of two microphones being used in the transmission of a song. But the transmission of an orchestral item may require several microphones, distributed carefully among the players according to the nature of their instruments. Only in this way can an orchestral performance be transmitted with the tones of all the instruments in proportion.

Then we must not forget the announcer, the voice of the station. He sits before another microphone, and acts as a guide to the listeners. He is always extremely

Continued on page 103

FOR DEPENDABILITY OF OPERATION USE
"IGRANIC" RADIO DEVICES

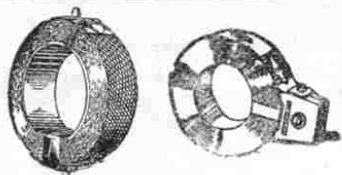
**HONEYCOMB INDUCTANCES**

(De Forest Patent No. 141344).

These world-famous coils are renowned for their high efficiency, low self-capacity, small absorption factor and minimum high frequency resistance. No dead-end losses. Each turn surrounded by air pocket. Made in two types, gimbal and plug mounted. Wave lengths approximately 100 to 25,000 metres. The only coils that uphold their claim for negligible losses. Prices vary with sizes.

**INTERVAL TRANSFORMERS**

(Patent No. 205013).

Designed for the distortionless reproduction of speech and music. The steel shroud effectively shields from external interference. Recent improvements in design render it the finest amplifying transformer obtainable. Prices: Shrouded, 21/- Open, 20/-.

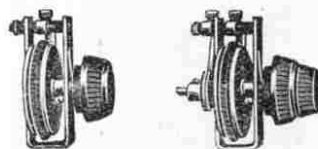
**FILAMENT RHEOSTATS**

(Patent No. 195903).

A splendid instrument for filament control under all conditions. Novel method of construction ensures smooth and silent operation. Designed for individual valve control. Adjustable contact finger permits of resistance values from zero to four ohms by fine variation. Supplied in two types, plain and vernier. Prices: Plain, 4/6. Vernier, 7/-.

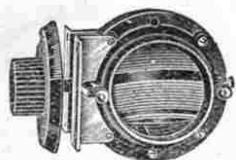
**TYPE "H" VARIOMETER**

Recommended for use in the aerial circuit of crystal and valve sets. Wave length range approximately 150-600 metres, with P.M.G. standard aerial. Stator and rotor best quality mouldings, windings self-supporting and impregnated solid. Price, with knob, dial and fixing bracket, 15/-.

*Obtainable from all Dealers.***TYPE H.R. VARIOCOUPLER**

Stator and rotor of hard moulded insulation and windings impregnated solid. Tappings on primary enable fine tuning to be obtained, thus eliminating condenser. Coupling continuously variable over wide range. Price, with knob, dial and fixing brackets, 19/-.

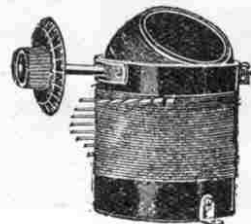
*Write for Lists Z. 171.**Glasgow.*

149,
Queen Victoria St.,
LONDON.

Bradford.

Works:
Elstow Road,
BEDFORD.

Cardiff.
Newcastle.
Birmingham

NO BOY OR GIRL can afford to be without the world-renowned and largely-advertised

SECCOTINE

(Regd. Trade Mark)

Tubes 4½d., 6d., 9d. Everywhere.

The best general adhesive the world knows. For wood, leather, bone, paper, etc., objects large or small. Used in bulk for manufacturing purposes. Of great utility to boys and girls who long to make things.

FIRMAS (Heat Seccotine)

(Regd. Trade Mark)

Tubes 6d.

For glass, china, delph, etc. Articles joined with it can be boiled without coming asunder.

McCAW, STEVENSON & ORR, LIMITED,
The LINENHALL WORKS, BELFAST.

Telegrams: "GLACIER, BELFAST."

Telephones: 4261 (3 lines).