

The New Meccano Ship-Coaler

An Old Favourite in a New Form

A mechanical ship-coaling apparatus forms an ideal subject for Meccano model-building. The model described below incorporates many entirely new features and constitutes a big improvement upon earlier Meccano structures of a similar nature.

FOR a long period the coaling of steamships was carried out entirely by hand labour, and even to-day this is the case in many eastern ports. Coaling by hand cannot be otherwise than a dirty operation, causing intense discomfort to all on board. The late Sir Frederick Treves, in his interesting book "The Other Side of the Lantern," gives a graphic description of the miseries of coaling at Port Said. "Clouds of coal-dust envelop the poor vessel," he says, "and penetrate into every part of it. The deck becomes an ash drift. Whatever the hand finds to touch, it finds to be black. Coal-dust becomes the breath of the nostrils, coal-dust settles upon the face, powders the neck, and creeps among the hair. Moreover, in no part of the ship is there any escape from the husky din which accompanies the ritual of coaling."

On this particular occasion the coaling took place at night from great coal-carrying rafts containing gangs of hundreds of coolies. Each raft carries high aloft cressets or iron baskets blazing with fire. "The rafts are made fast to the great vessel, planks are run up to the coal bunkers, and then there begins an unceasing procession of gaunt folk carrying yellow baskets full of coal up one plank and returning with them empty along another. As they pass up and down, their rags dance in the wind, clouds of coal-dust and smoke circle round them, while the light from the cressets flashes fitfully upon the file, making their sweating limbs glow as with a fervent heat. The stream of basket carriers might be coming out from the crater of a volcano, and it is a matter of wonder that they are neither charred nor smothered . . .

"Hour after hour the dry tramp of feet along the plank continues, hour after hour the same hoarse dirge is screamed forth from a hundred creaking throats, hour after hour the spades are at work and the baskets come and go. Then the scuffle of feet ceases, the scrape of the shovels dies away, the fire in the cressets flutters out, the barges are empty, and to the same weird chant they glide away and are lost in the gloom." Such methods are picturesque but unscientific.

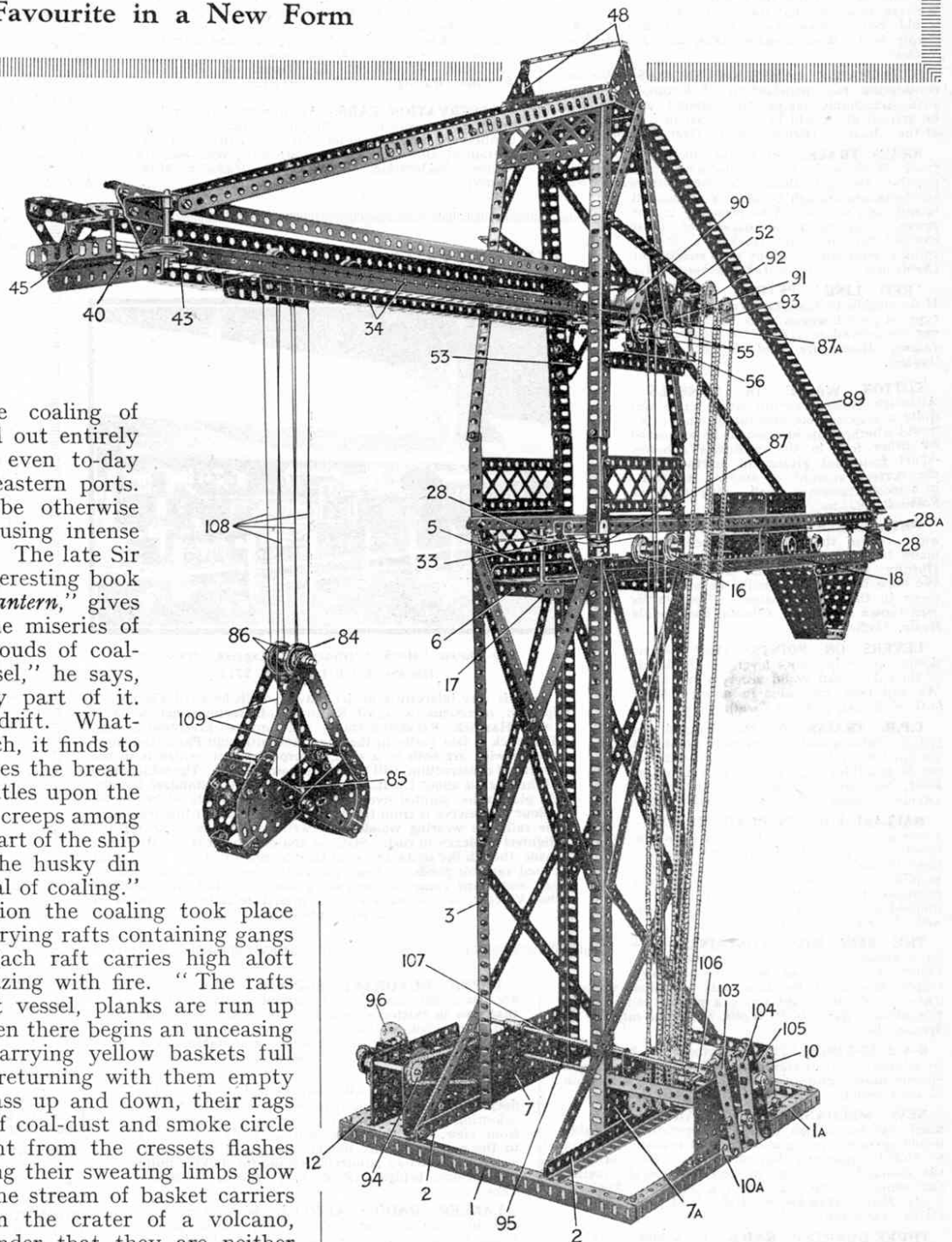

Fig. 1. General view of the Model

Coaling by Machinery

Coaling by hand on these lines is only possible in parts of the world where ample and cheap native labour is available. Elsewhere machinery must be called into play to carry out operations at a sufficient speed, and yet economically. The method employed for transferring the coal from the quayside to the ship's bunkers varies considerably in different ports, according to local

conditions and circumstances. The coaling facilities of the larger ports are naturally on a more elaborate and more interesting scale than those at the smaller ports. At Liverpool, for instance, one well-known firm has a whole fleet of floating coaling machines operated by grab in conjunction with belt conveyor, and also by bucket elevator and chutes. These machines correspond very closely in their working principles to the Meccano model about to be described.

The grab machines do not themselves carry any coal, but are moored alongside the vessel to be coaled, and barges containing the coal are brought alongside the grab machines. The grab is lowered into the barge, from which it takes up in its great steel jaws a mouthful of coal weighing something over a ton. This coal is raised to whatever height may be required and is then released on to a travelling belt conveyor, by which it is carried across the deck of the vessel to the hatchways. In the Meccano model, the automatic discharging truck corresponds to the belt conveyor.

While the coal is on its journey along the conveyor the grab descends again and takes up another load, and so the process goes on, the loading proceeding at the rate of over 100 tons per hour. As soon as one barge is emptied, another one takes its place, so that the loading continues without interruption until the necessary amount of coal has been taken on board.

The machines operated by bucket elevator and chutes differ from the grab machines in that they themselves carry the coal. They are capable of holding from 1,000 to 1,100 tons. The coal is made to fall in regulated quantities through a false bottom on to a travelling chain of buckets, which lift it to the top of the machine and discharge it down chutes directed either over the decks into hatchways, or into side ports. By means of elevator machines coaling can be carried out at the rate of some 300 tons per hour. In addition, the coal can be delivered overall to a height of more than 50 ft., thus ensuring the speedy coaling of a large liner without any necessity for the vessel to move from her loading or discharging berth.

The Meccano High-speed Ship-coaler has been designed specially to illustrate the possibilities of mechanical coaling. It is one of the most interesting of all Meccano models, and if carefully constructed it operates with wonderful precision and in a most realistic manner. The whole of the movements necessary for coaling a miniature ship are controlled from a central gear box situated in the base of the model, and are carried out with perfect accuracy. The model is one that makes a particular appeal to Meccano enthusiasts because, in addition to the enjoyment of building it, it affords endless fun when completed. Moreover, a considerable amount of dexterity is required for its successful manipulation. There are so many movements that the operator has to use his intelligence all the time, and must be quick with his fingers in order to carry out the various stages without a hitch. In other words, it is just as exciting to operate as it is to build—an ideal model for all really enthusiastic Meccano Boys. It is particularly suited for use in loading Hornby Wagons from a miniature coal-dump.

The Main Tower

The construction of the model should be commenced by building the main tower. Fig. 2 shows the tower in detail, with superstructure, gearing, etc., removed. The base of the tower consists of four $12\frac{1}{2}$ " Angle Girders 1 bolted in the form of a square and spanned by two similar Girders 2. Four $24\frac{1}{2}$ " Angle Girders 3, forming the chief supports of the tower, are braced at the top by the $5\frac{1}{2}$ " Angle Girders 6, 6a and the $5\frac{1}{2}$ " Braced Girders 4, 5, whilst their lower ends are joined by two $5\frac{1}{2}$ " \times $2\frac{1}{2}$ " Flat Plates 7, 7a. The rigidity of the structure is increased by crossed $12\frac{1}{2}$ " Strips 8, 9.

The framework of the gear box is formed by erecting a $5\frac{1}{2}$ " \times $2\frac{1}{2}$ " Flat Plate 10 edgewise on one of the base Girders

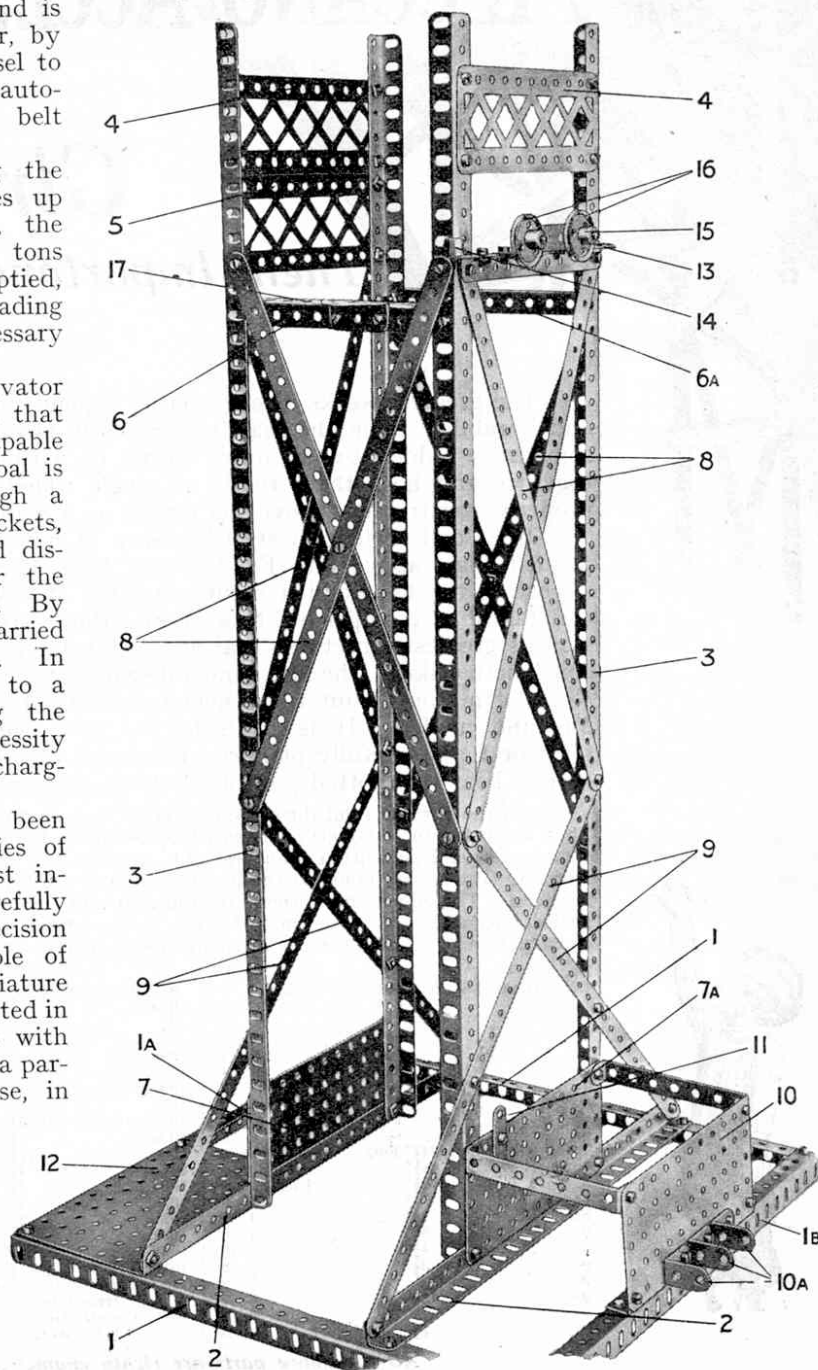

Fig. 2. Detail view of Main Tower

1 and joining it to the Plate 7a by means of two $3\frac{1}{2}'' \times \frac{1}{2}''$ Double Angle Strips. Three $1'' \times 1''$ Angle Brackets 10a are secured to the outer side of the Plate 10, and a $1\frac{1}{2}''$ Strip 11 is attached in a vertical position to the Plate 7a. A $5\frac{1}{2}'' \times 3\frac{1}{2}''$ Flat Plate 12, bolted to the base in the position shown, forms the bed to which an Electric Motor will later be attached.

A $5\frac{1}{2}''$ Angle Girder 13 bolted near the upper ends of two of the Girders 3, above the gear box, carries a Crank 14, and a $2''$ Angle Girder 15 secured to the Girder 13 carries two $1''$ loose Pulley Wheels 16, which are mounted on Threaded Pins and kept in position by Collars and set-screws. The addition of a Trunnion 17 to the Girder 6 completes the construction of the main tower unit. Care should be taken that all parts are situated correctly, as each will have a definite use in the completed model.

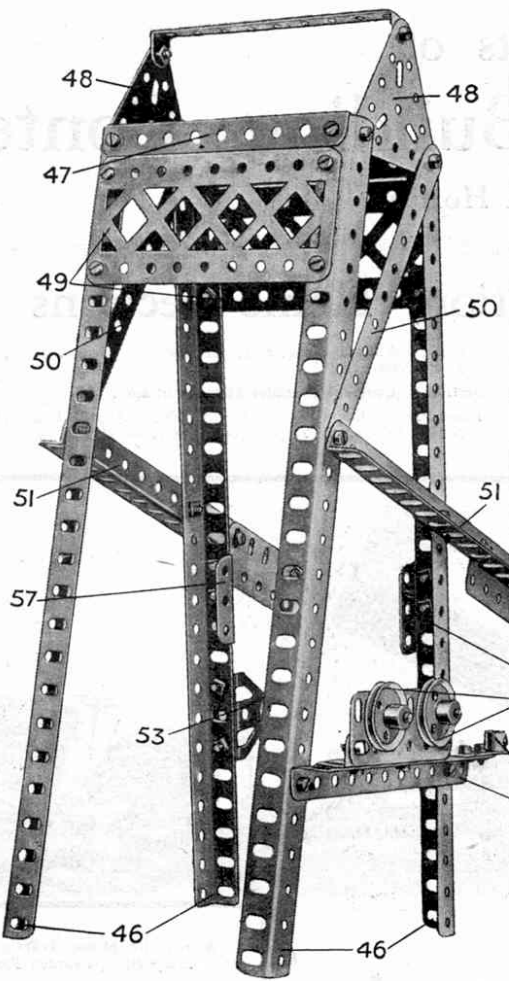

Fig. 3. Upper Portion of Tower, with Gearing and Mechanical Details, etc., removed

Upper Portion of Tower

The upper tower (Fig. 3) is built of four $12\frac{1}{2}''$ Angle Girders 46 surmounted by two $4\frac{1}{2}''$ Angle Girders 47 and two $2\frac{1}{2}''$ Triangular Plates 48 joined by a $4\frac{1}{2}'' \times \frac{1}{2}''$ Double Angle Strip. The wider sides of the tower are strengthened by $4\frac{1}{2}''$ Braced Girders 49, and the narrow sides by two $5\frac{1}{2}''$ Strips 50. To the ends of these Strips 50 are bolted the $7\frac{1}{2}''$ Angle Girders 51, the projecting ends of which slope downward and carry $2\frac{1}{2}''$ Flat Girders 52. Below the Girders 51, two $1\frac{1}{2}''$ Angle Girders 57 are attached to the upright 46 as shown, and further down, on one side only, is a Trunnion 53.

The $5\frac{1}{2}''$ Angle Girder 54 carries a $3''$ Angle Girder and a $3''$ Flat Girder, to which the $1''$ loose Pulleys 55 are attached by Threaded Pins in the same way as the Pulleys 16 (Fig. 2). A Crank 56 is bolted as shown (Fig. 3) to the short projecting end of the Girder 54.

The Truck Runway

The construction of the truck runway, together with the chute from which the coal is finally discharged into the hold of the ship,

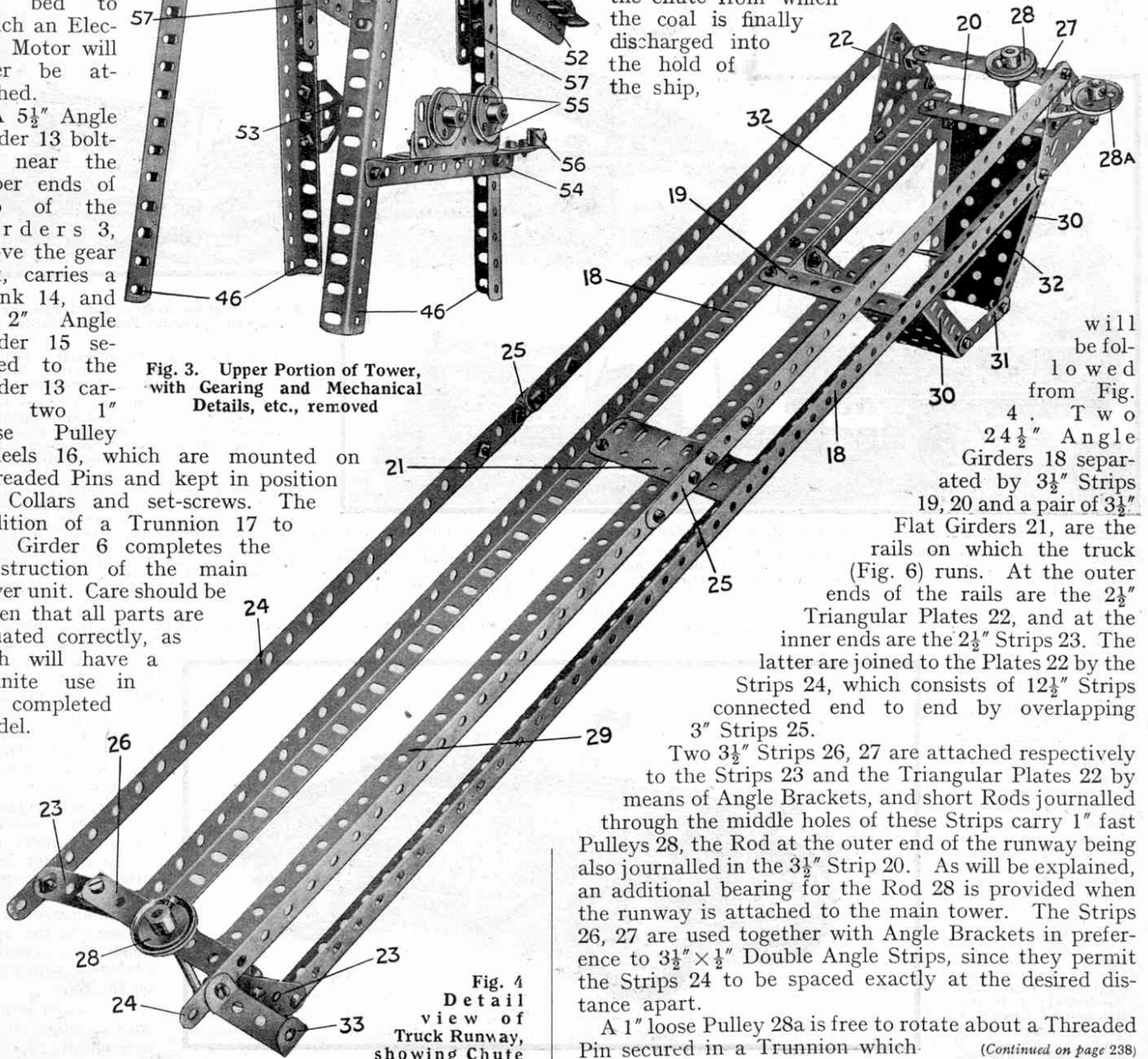

Fig. 4. Detail view of Truck Runway, showing Chute

will be followed from Fig. 4. Two $24\frac{1}{2}''$ Angle Girders 18 separated by $3\frac{1}{2}''$ Strips 19, 20 and a pair of $3\frac{1}{2}''$ Flat Girders 21, are the rails on which the truck (Fig. 6) runs. At the outer ends of the rails are the $2\frac{1}{2}''$ Triangular Plates 22, and at the inner ends are the $2\frac{1}{2}''$ Strips 23. The latter are joined to the Plates 22 by the Strips 24, which consists of $12\frac{1}{2}''$ Strips connected end to end by overlapping $3''$ Strips 25.

Two $3\frac{1}{2}''$ Strips 26, 27 are attached respectively to the Strips 23 and the Triangular Plates 22 by means of Angle Brackets, and short Rods journalled through the middle holes of these Strips carry $1''$ fast Pulleys 28, the Rod at the outer end of the runway being also journalled in the $3\frac{1}{2}''$ Strip 20. As will be explained, an additional bearing for the Rod 28 is provided when the runway is attached to the main tower. The Strips 26, 27 are used together with Angle Brackets in preference to $3\frac{1}{2}'' \times \frac{1}{2}''$ Double Angle Strips, since they permit the Strips 24 to be spaced exactly at the desired distance apart.

A $1''$ loose Pulley 28a is free to rotate about a Threaded Pin secured in a Trunnion which

(Continued on page 238)

Famous Trains—(continued from page 217)

carries the breathless traveller up no less than 2,145 ft. with a maximum gradient of 87.8 per cent., which is rather steeper than 1 in $1\frac{1}{2}$! It claims, and not without reason, to be the steepest railway in the world, and, like most lines of a steeper inclination than 1 in 2, is worked by a steel cable.

Below Piotta, on our journey, comes some even more striking engineering than that of Gurtellen and Wassen. From Rodi Fiesco to Faido, as the crow flies, is only $2\frac{1}{2}$ miles, but the difference in level between the two places is 613 ft., and in order to overcome it the railway has circuitously to travel five miles, with a maximum gradient of 1 in 38, threading on the way two tunnels that are completely spiral. Then, as the river rushes down the Biaschina Ravine, and we approach Giornico, just before we enter Piano Tondo Tunnel, we notice a second stretch of the line below us, and a further stretch below that, the latter making its exit from the mountain-side some 300 ft. below our entrance. Here there are two cork-

screw tunnels—Piano Tondo and Travi, both just under a mile in length—side by side, in order that the railway may keep pace with the sudden fall in the level of the valley-floor. A downward run of 41 miles from Airolo brings us to Bellinzona, where we have fallen to a level of 760 ft., or just over 3,000 below the level of the St. Gotthard Tunnel. The time is now 11.35 a.m. and the stop lasts but two minutes.

Bellinzona is the junction for the historic town of Locarno, which we see, some miles off, on the shores of Lake Maggiore, as we ascend to the mile-long Monte Ceneri Tunnel that carries us under the watershed separating the Ticino Valley from that of the Lake of Lugano. This has necessitated a fresh ascent of 800 ft. in $8\frac{1}{2}$ miles, once again on single line, to Rivera (1,560 ft.), after which we drop a corresponding distance, down the fertile Vedeggio Valley, to lovely Lugano, where the station is high above the lake and 1,010 ft. above the sea. The time of the halt here is from 12.7 to 12.10 midday.

Skirting the shore of the lake, by means of tunnels and bold viaducts, we descend to the lakeside at Melide, and then cut clean across the lake by a remarkable causeway to Bissone. Here we are down to 900 ft., but another rise of 280 ft. ensues in the next six miles, ere we can drop to the frontier station at Chiasso,

reached at 12.34 p.m.

Within Swiss territory the "St. Gotthard Pullman" has now travelled for 198 miles, of which 140 miles have been over the marvellous St. Gotthard route. In the course of this latter distance it has passed through 80 tunnels whose aggregate length is $28\frac{1}{2}$ miles, and over no less than 324 bridges of more than 32 ft. span, many of them viaducts of no

Conquest of the Air—(continued from page 207)

one of whom was a lady, who were clinging to a slender screen of osier, for whom every second seemed counted, no one had fear. All tongues were mute, all faces were calm. Nadar held his wife, covering her with his body. Poor woman! Every shock seemed to break her to pieces.

"Jules Godard then tried and accomplished an act of sublime heroism. He clambered up into the netting, the shocks of which were so terrible that three times he fell on my head. At length he reached the cord of the valve, opened it, and the gas having a way of escape the monster ceased to rise, but it still shot along in a horizontal line with prodigious rapidity. There were we squatting down upon the frail osier car. 'Take care!' we cried, when a tree was in the way. We turned from it and the tree was broken; but the balloon was discharging its gas, and if the immense plain we were crossing had yet a few leagues, we were saved. But suddenly a forest appeared on the horizon; we must leap out at whatever risk, for the car would be dashed to pieces at the first collision

with those trees. I got down into the car, and raising myself, I know not how, for I suffered from a wound in my knees, I jumped, and made I know not how many revolutions, and fell upon my head. After a minute's dizziness I rose. The car was then far off."

The publicity that Nadar gave to his idea of a huge aerial screw had the effect of leading other inventive aeronauts, who did not wholly accept his views, to endeavour to apply the screw principle to lighter-than-air balloons. Next month we shall deal with these pioneer efforts to construct a practical mechanically propelled airship.

(To be continued)

Clearing the Railways of Snow



[Courtesy]

[Southern Railway]

A Scene on the Alton and Winchester Line during the January snowstorms. Workmen are clearing a cutting in which a train was buried

inconsiderable size. Small wonder is it that the total cost of the St. Gotthard line was nearly three hundred million francs, which represents about twelve million pounds.

At Chiasso the Swiss Federal authorities hand us over to the care of the Italian State Railways, after the Customs authorities have taken 18 minutes in which to examine our baggage, and a run of 32 miles, through Como, where a 2-minute stop is made, and across the Plain of Lombardy, brings us 63 minutes later to the great city of Milan. It is 1.55 p.m. and our journey of 230 miles, over these terrific gradients, has taken us 6 hrs. 43 min., whereas the very quickest journey possible between Basel and Milan in pre-war days was 8 hrs. 5 min. This shows how remarkable are the advantages derived by the passenger from the electrification.

The "St. Gotthard Pullman" has not yet finished its day's work, however. At 4.5 p.m. the same afternoon, it will be starting northward again out of Milan. Six o'clock in the evening will find it at Lugano and 9.15 at Lucerne; while the tired rolling stock, after 460 miles of travelling, will find its way into the great Central Station at Basel at 10.44 p.m. at night, there to disgorge its passengers into the night expresses leaving for all parts of Central and Western Europe.

The New Meccano Ship-Coaler—

(Continued from page 253)

in turn, is bolted to one of the Triangular Plates 22. A Collar with set-screw keeps the Pulley in position. A $1\frac{1}{2}$ " x $\frac{1}{2}$ " Double Angle Strip 33 is bolted to the second hole at the inner end of one of the Strips 24.

The guide rail 29 consists of two $12\frac{1}{2}$ " Strips, one end of each Strip being clamped between two Flat Girders 21; this rail also passes between two $3\frac{1}{2}$ " Strips 19, and its end is curved downward to overhang the chute. The latter consists of two Sector Plates 30 joined by 2" Strips 31 and bolted to $5\frac{1}{2}$ " Angle Girders 32 on the underside of the rails 18.

The New Meccano Ship-Coaler

An Old Favourite in a New Form

(Concluded from last month)

LAST month we described the construction of the tower framework and the truck runway, with chute, etc. In this issue we conclude our description of the Ship-Coaler by explaining the construction of the trolley runway and the mechanical details.

Fig. 5 shows the trolley runway in detail. The rails 34, which are traversed by the trolley from which the grab is suspended, and the strengthening members 35 consist of $2\frac{1}{2}$ " Angle Girders, and are joined vertically at each end by a pair of 2" Strips. These 2" Strips are arranged in such a way that the Girders 35 project $\frac{3}{4}$ " further from the tower than the rails 34. The rails

joined by $2\frac{1}{2}$ " \times $2\frac{1}{2}$ " Flat Plates form the walls of the truck, and the hinged bottom consists of a $3\frac{1}{2}$ " \times $2\frac{1}{2}$ " Flat Plate 58. A 3" Rod 59, journalled in Angle Brackets bolted to one of the end Plates, is retained in position by Collars, and acts as a pivot for a $2\frac{1}{2}$ " \times 1" Double Angle Strip 61 bolted to the Plate 58.

The truck runs on four $\frac{3}{4}$ " Flanged Wheels secured to $3\frac{1}{2}$ " Rods, each wheel being spaced away from the sides of the truck by two Washers. The $\frac{1}{2}$ " loose Pulley Wheel 64 turns freely on a Pivot Bolt mounted in two Angle Brackets, which are secured to the ends of two $2\frac{1}{2}$ " Strips bolted to the Plate 58.

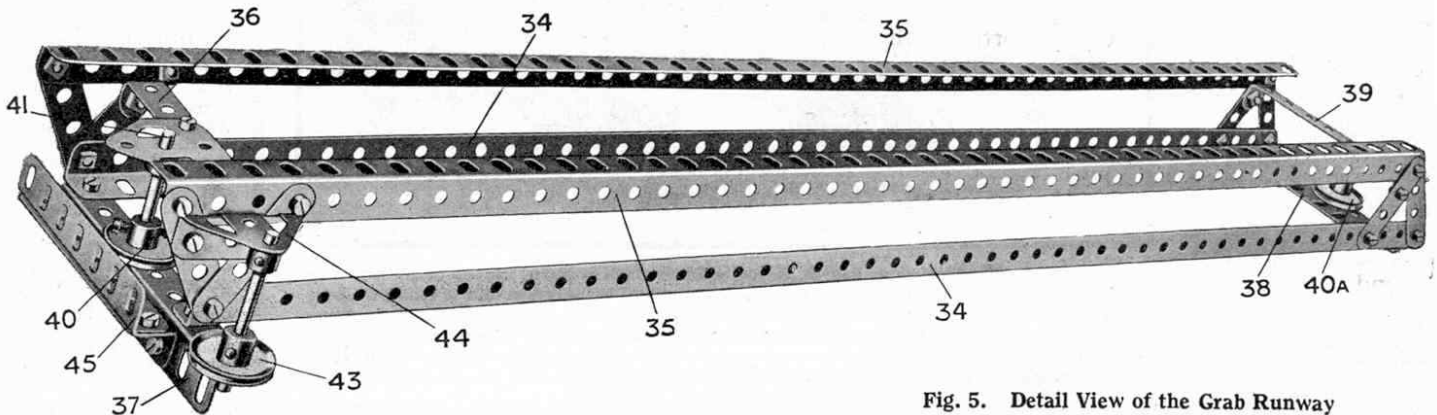

Fig. 5. Detail View of the Grab Runway

are spaced apart by the $4\frac{1}{2}$ " Angle Girder 37 (the end of which projects 1") and the $3\frac{1}{2}$ " Flat Girder 38, while two $3\frac{1}{2}$ " \times $\frac{1}{2}$ " Double Angle Strips 36, 39 are bolted between the end 2" Strips.

A 1" loose Pulley Wheel 40a is mounted on a Threaded Pin secured to the Flat Girder 38, but is prevented from moving vertically by a Collar and set-screw. At the outer end of the runway a 1" Pulley Wheel 40 is fixed to a 2" Rod 41 journalled in bearings consisting of the Girder 37 and a Flat Trunnion bolted to the Double Angle Strip 36. A second 1" fast Pulley 43 similarly is secured to a 2" Rod journalled in the projecting end of the Girder 37 and a Trunnion 44 bolted to one of the pairs of 2" Strips. The $3\frac{1}{2}$ " Angle Girder 45 is mounted on a similar Girder bolted to the $4\frac{1}{2}$ " Angle Girder 37.

The Truck

Fig. 7 is a view of the underside of the automatically-discharging truck, which runs on the rails 18 (Fig. 4). Two $3\frac{1}{2}$ " \times $2\frac{1}{2}$ " Flanged Plates

The Grab Trolley

The grab trolley traverses the rails 34 (Fig. 5), and from it is suspended the grab.

Two $3\frac{1}{2}$ " Flat Girders form the sides of the trolley (Fig. 6). They are joined by $1\frac{1}{2}$ " \times $\frac{1}{2}$ " Double Angle Strips 67, and their end holes form journal bearings for the 3" Axle Rods carrying the four $\frac{3}{4}$ " Flanged Wheels. Two 2" Rods 69 journalled in the $3\frac{1}{2}$ " Flat Girders carry two $1\frac{1}{2}$ " Strips 72 and three pairs of $\frac{1}{2}$ " loose Pulley Wheels 73, 74, and 75 which are spaced apart by fixed Collars. Washers should be placed between the Pulleys 73 and 75 and the side Girders.

The Grab

Each jaw of the grab (Fig. 8) is composed of two $2\frac{1}{2}$ " Triangular Plates pivoted on a 2" Axle Rod 78 and joined by $1\frac{1}{2}$ " \times $\frac{1}{2}$ " Double Angle Strips 79. Four $2\frac{1}{2}$ " Curved Strips (small radius) are bolted to the Triangular Plates, and to these are attached the $1\frac{1}{2}$ " Strips 80,

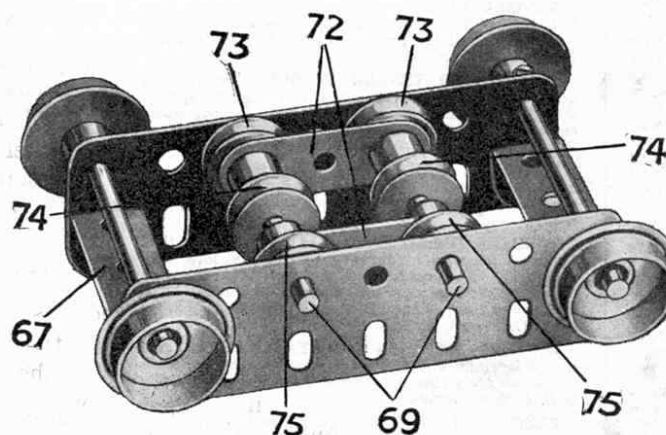

Fig. 6. The Grab Trolley

which are mounted pivotally on 2" Rods 81. Four 3½" Strips 82 also pivot about the Rods 81, and a 2½" Rod 83 journalled through their upper ends carries two 1" fast Pulley Wheels 86 and two ½" loose Pulleys 84. The Rods 81 and 83 are held in position by Collars and set-screws.

Two ¾" Flanged Wheels 85 are butted together on the Rod 78 to form a wide-grooved pulley. The Rod 78 is held in place between the Triangular Plates by Collars made fast to its ends.

Assembly of the Main Units

The two portions of the tower are united by bolting the lower ends of the Angle Girders 46 (Fig. 3) to the tops of the Girders 3 (Fig. 2). The Angle Girders 6, 6a, and the outer ends of the runway are supported by two 24½" Angle Girders 89 (Fig. 1) bolted to the Girders 46 of the upper tower.

The grab runway is mounted pivotally on a 4½" Axle Rod journalled in the lower holes of the 1½" Angle Girders 57 (Fig. 3) and its outer end is supported by two ties, each consisting of a 12½" Angle Girder and a 12½" Strip overlapped nine holes, which connect it to the top of the tower.

The end of the 2" Rod bearing the 1" Pulley Wheel 28 at the inner end of the truck runway may now be passed through a hole in the Trunnion 17 (Fig. 2). A ½" loose Pulley Wheel 87 (Fig. 1) is mounted on a 2" Axle Rod secured in the boss of the Crank 14 (see also Fig. 2) and passes through the 1½" x ½" Double Angle Strip 33. A similar wheel 87a is supported at the inner end of the grab runway by a Collar on another 2" Rod that is made fast in the boss of the Crank 56.

The drums on which are wound the cords for operating the grab are formed by Meccano Wood Rollers 90, 91 (part No. 106), which are gripped between Bush Wheels secured to 6½" Axle Rods that are journalled in the 2½" Flat Girders 52 (Fig. 3). These Rods are retained in position by means of Collars and set-screws, and carry on their ends the 1" Sprocket Wheels 92, 93. Their other ends pass through the loops at the ends of two Springs, which are attached to the Trunnion 53 (Fig. 3) and are constantly under

tension. The friction thus set up prevents the weight of the grab from unwinding the cords on the Rollers when the latter are disconnected from the driving mechanism.

A Meccano Electric Motor should next be bolted to the Flat Plate 12 in the position shown (Fig. 1).

Transmission and Gearing

The gear box and various controls are shown in Fig. 9. The arrangement of the mechanism is as follows. A Worm Wheel secured to the armature spindle of the Electric Motor meshes with a 57-teeth Gear Wheel 96 on a 2" Rod that is journalled in a Channel Bearing secured to the side of the Motor frame. A ⅞" Bevel Gear, carried on the opposite end of the 2" Rod, engages with a similar Bevel Gear, from the Rod of which the drive is led via a ¾" Sprocket Wheel 94 to a 2" Sprocket Wheel on the end of the 11½" Axle Rod 95. This Rod 95 passes through the Flat Plates 7a, 10, and is provided with two ½" Pinion Wheels 97, 98.

Three 6½" Axle Rods 99, 100, 101 are journalled in the side Plates 7a and 10 of the gear box. The first of these carries a 57-teeth Gear Wheel to mesh with the ½" Pinion 97, and two Sprocket Wheels that engage short Sprocket Chains, to the ends of which are tied lengths of cord.

The cords thus connected to the inner 1" Sprocket Wheel pass round the 1" Pulley Wheels 16, 14, 28a and 28, and are tied to opposite ends of the truck, while those from the outer Sprocket Wheel are led around the Pulleys 55, 43, 40, 56, 40a and are tied to the grab trolley. When the Rod 99 revolves, therefore, the truck and the grab trolley are simultaneously drawn inward or outward. Their positions should be so adjusted before securing that the grab trolley will come to rest in the tower immediately above the truck.

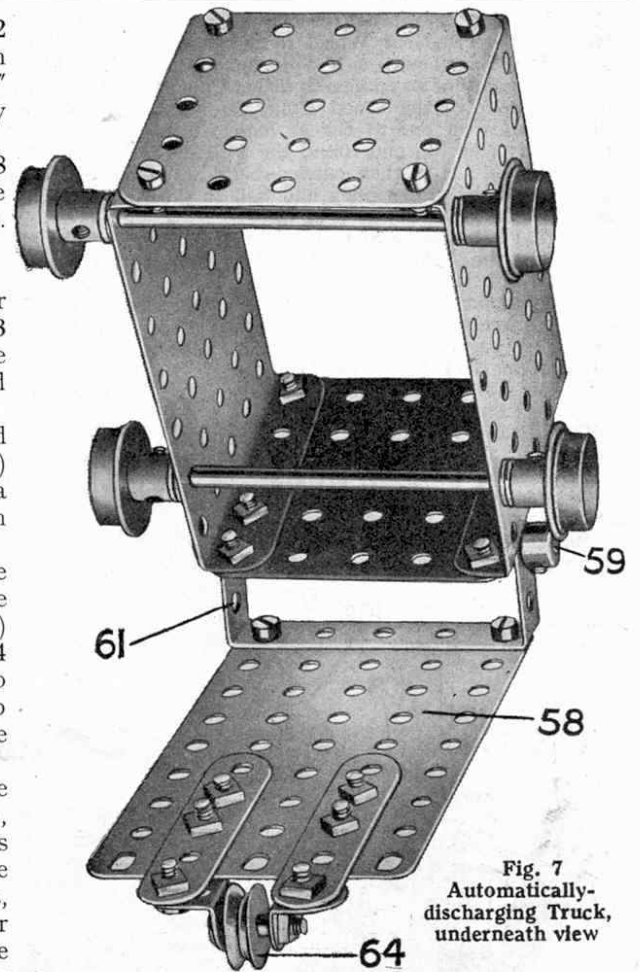

Fig. 7. Automatically-discharging Truck, underneath view

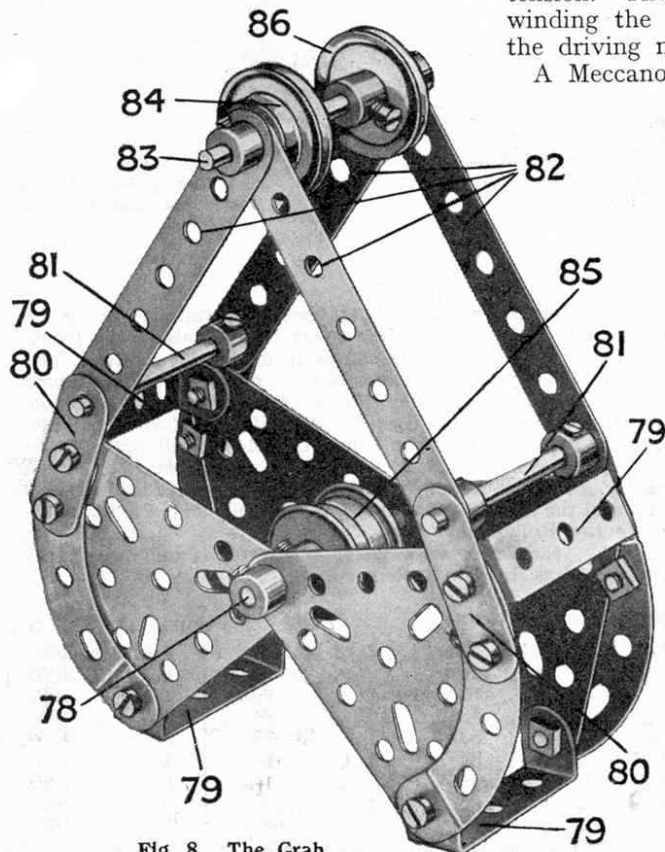

Fig. 8. The Grab

The Rod 100 is situated directly above the 11½" Rod 95, and carries a 57-teeth Gear Wheel to mesh with the ½" Pinion 98. It also is provided with a 1" Sprocket Wheel 102, which is connected by means of an endless Sprocket Chain to a similar wheel 92 on the spindle of the Wood Roller 90. A cord wound on this roller passes over one of the ½" loose Pulley Wheels 74 in the grab trolley (Fig. 6), and round the ¾" Flanged Wheels 85 of the grab (Fig. 8). It is then carried back and over the second ½" Pulley 74 in the grab trolley and tied to the Angle Girder 45 at the end of the grab runway (Fig. 5).

The Rod 101 bears a 57-teeth Gear Wheel that can be made to engage with the ½" Pinion 97. It is also provided with a 1" Sprocket Wheel, which is connected by another endless Sprocket Chain to the Sprocket Wheel 93 driving the Roller 91 (Fig. 1). This Roller is provided with two cords for raising and lowering the grab. These cords pass over the ½" loose Pulley Wheels 73, 75 of the grab trolley, under the 1" Pulley 84 of the grab, and back over the second pair of ½" Pulley Wheels 73, 75, and are finally tied to the Angle Girder 45.

The Axle Rods 99, 100, 101 are all slidable in their bearings, and their movements are controlled by means of the handles 103, 104,

a 2" Rod. The latter is attached to the central starting lever of the Motor by means of an End Bearing (part No. 166).

When the handle 105 is pushed inward the grab closes if the hoisting mechanism is stationary; if the Electric Motor be reversed, the grab will open. Operation of the handle 104 causes it to be raised or lowered, but the handle 105 should be thrown at the same time in order to prevent the cord 107 from becoming slack when the grab is rising, or retarding the progress of the latter if it is descending. Care should be taken that the cords are wound on the Rollers 90, 91 in the correct directions so that all three cords 108, 109, operating the grab are either paid out or hauled in simultaneously when the handles 104, 105 are thrown together.

The handle 103, when thrown, causes both the truck and the grab trolley to travel inward or outward, according to the direction in which the Motor is running.

If the sides of the grab and the chute are filled in with stout cardboard, gravel or some similar substance may be used as a substitute for coal, and the model made to function in exactly the same manner as its prototype does in actual practice.

The Ship Coaler should be placed with the end of the trolley runway immediately above the heap of coal, while the chute should overhang some receptacle representing the bunkers of a ship. The usual procedure for operating the model is as follows. The grab and truck are first run out to their farthest extent. The grab is then lowered, being opened during the descent, and on reaching the heap of coal to be loaded it is caused to close. Next the Motor

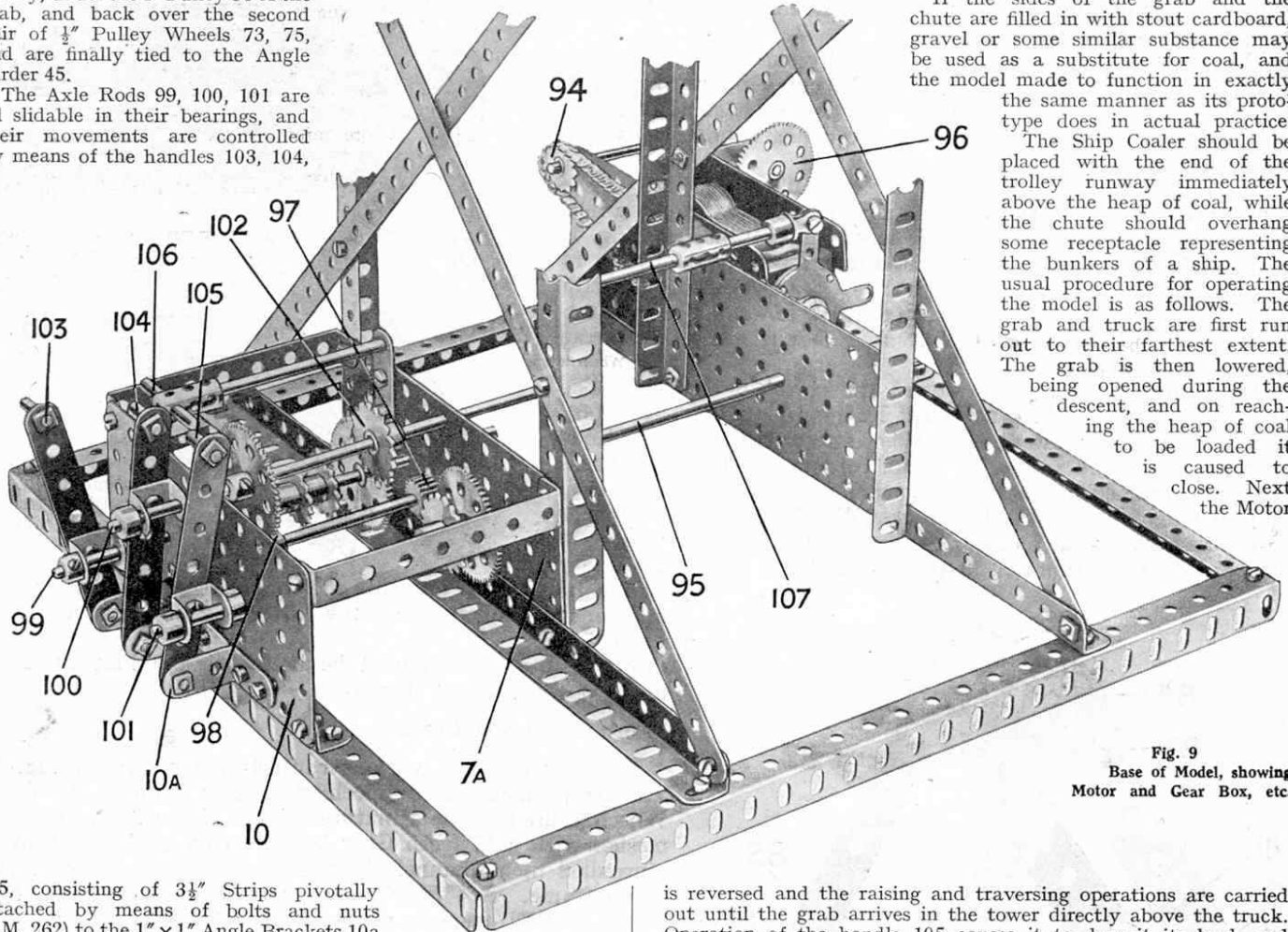

Fig. 9
Base of Model, showing
Motor and Gear Box, etc.

105, consisting of 3½" Strips pivotally attached by means of bolts and nuts (S.M. 262) to the 1" x 1" Angle Brackets 10A (see also Fig. 2). The 3½" Strips are connected to the sliding Rods by means of Double Brackets, which are retained in position on the Rods by Collars and pivoted to the Strips by means of bolts and lock-nuts (S.M. 263). The Gear Wheels on the Rods 99, 100, 101, can thus be brought in or out of engagement with the ½" Pinion Wheels 97, 98 by operation of their respective handles.

The Electric Motor is controlled by a handle 106, consisting of a 2" Rod secured in the end transverse hole of a Coupling on the extremity of an 8" Rod 107, which is extended by a Coupling and

is reversed and the raising and traversing operations are carried out until the grab arrives in the tower directly above the truck. Operation of the handle 105 causes it to deposit its load, and the original outward movement is then repeated. The dipping centre rail of the truck runway (Fig. 4) presently allows the bottom of the truck to open and drop its load of coal down the chute.

A little adjustment to the completed model will probably be necessary to ensure that the different movements are timed correctly. This is effected by altering the positions of the Sprocket Chains and the cords wound on the Wood Rollers 90, 91, for which purpose the Rollers and Sprocket Wheels may be loosened on their axles, the set screws being made fast again when the mechanism has been adjusted correctly.

Parts Required to Build the Meccano Ship Coaler :

18 of No. 1	4 of No. 9	5 of No. 14	4 of No. 27A	4 of No. 48B	2 of No. 72	5 of No. 103D
2 " " 2	3 " " 9A	1 " " 15	2 " " 30	1 " " 48C	8 " " 76	1 " " 103E
12 " " 3	2 " " 9B	3 " " 16	1 " " 32	1 " " 52A	4 " " 90A	2 " " 103F
2 " " 4	2 " " 9C	2 " " 16A	312 " " 37	2 " " 53	15' " " 94	2 " " 106
4 " " 5	2 " " 9F	2 " " 16B	6 " " 37A	1 " " 53A	1 " " 95	9 " " 115
10 " " 6	3 " " 11	12 " " 17	20 " " 38	2 " " 54	4 " " 96	4 " " 126
7 " " 6A	8 " " 12	2 " " 18A	2 " " 43	38 " " 59	3 " " 96A	1 " " 126A
12 " " 7	3 " " 12A	10 " " 20B	1 " " 46	2 " " 52	2 " " 100	1 " " 160
14 " " 8	1 " " 13	4 " " 24	8 " " 48	3 " " 70	2 " " 100A	1 " " 166
2 " " 8B	1 " " 13A	2 " " 26				
				1 4-volt Meccano Electric Motor		