

# The New Meccano Motor Chassis

## An Example of the Latest Meccano Construction

THE Meccano Motor Chassis forms not only an excellent example of the adaptability of the Meccano parts but also a striking illustration of the educational value of the Meccano system. It shows how, with the aid of a number of ordinary Meccano parts, any intelligent boy may build a complete working model that demonstrates the principles of modern motor engineering so well that replicas of it have been used to instruct pupils in numerous technical schools.

The motor chassis about to be described embodies numerous improvements upon models of a similar type that have been published previously, and it may be regarded as representing the latest Meccano practice. Amongst the improvements may be mentioned the unit principle of construction that has been adopted. The motor, clutch and gearbox are all mounted on a rigid frame, which may be detached from the chassis merely by loosening two or three screws. The differential and rear axle casing, with torque rods, etc., also form a complete unit, the removal of which is the work of a few seconds only.

The gearbox provides three speeds forward and reverse gear, and is controlled by a central gear-change lever sliding in a quadrant that retains it in position after each change is effected. The clutch is controlled by a foot pedal and providing that a small rubber ring is used in the manner to be described later, the drive from the motor may be taken up very smoothly and gradually and transmitted to the road wheels. The differential gear has been improved and made more compact. The back axle unit is mounted on cantilever springs and any twisting tendency set up by the thrust of the propeller shaft is counteracted by torque rods attached to the main frame by a spring connection.

The steering gear is designed according to the Ackermann principle, which provides for a different angle of turning movement in each front road wheel. Internal expanding brakes are attached to the rear wheels and a pedal-operated brake is fitted to the cardan shaft immediately in front of the universal joint. Other refinements of the model include a radiator cooling fan and a motor starting switch mounted on the dashboard.

The chassis will carry easily the weight of the Meccano 8 ampere-hour Accumulator, even on top gear. The Accumulator should

be placed on the luggage carrier at the rear of the model, thus converting the chassis into a self-contained power unit. A complete list of parts required to build the model will be found at the end of this article.

### The Frame and Springs

The construction of the model should be commenced by building the main frame, which is shown more clearly in Fig. 2. Each side consists of two  $12\frac{1}{2}$ " Angle Girders 1 bolted together in the form of a channel section to give maximum rigidity. The side girders are held together by a cross member 2 composed of a  $5\frac{1}{2}$ " Angle Girder and their front ends are extended by  $5\frac{1}{2}$ " Curved Strips to carry the ends of the front semi-elliptic springs. Each inner  $5\frac{1}{2}$ " Curved Strip is secured to the upper Girder of its respective side member by means of two Angle Brackets. Two of the bolts that serve to secure the Curved Strips also serve as pivots for the shackles (Flat Brackets 3) supporting the rear ends of the front springs (see also Figs. 4 and 6). The bolts should be secured to the side members by two locked nuts (see Meccano Standard Mechanism No. 262) so that the Flat Brackets are quite free to turn on their shanks.

The main frame is extended and carried over the back axle by means of a series of  $2\frac{1}{2}$ " large radius Curved Strips 4 bolted together in the manner shown. The luggage carrier 5 is composed of two 3" Strips connected by four  $4\frac{1}{2}$ " x  $\frac{1}{2}$ " Double Angle Strips. The carrier is bolted to the end holes in the main frame, and nuts on bolts 6 inserted in the end holes of the 3" Strips strike against the Curved Strips 4 and thereby maintain the carrier in a horizontal position. The carrier is designed to hold the Meccano 8 amp. Accumulator, and when not in use it may be folded back.

The radiator is represented by a  $3\frac{1}{2}$ " x  $2\frac{1}{2}$ " Flanged Plate 7 with two  $3\frac{1}{2}$ " x  $\frac{1}{2}$ " Double Angle Strips bolted at the sides. It is secured to a  $4\frac{1}{2}$ " Strip 7a secured between the front  $5\frac{1}{2}$ " Curved Strips of the frame. The  $5\frac{1}{2}$ " x  $2\frac{1}{2}$ " Flat Plate 8 is secured to a  $5\frac{1}{2}$ " Angle Girder bolted to the main side Girders 1 and is extended at the top by a  $5\frac{1}{2}$ " Strip 9 secured at each end by Flat Brackets. The dashboard 10 consists of a  $5\frac{1}{2}$ " Strip and a  $5\frac{1}{2}$ " Curved Strip attached

Fig. 3. Diagram showing car in act of turning

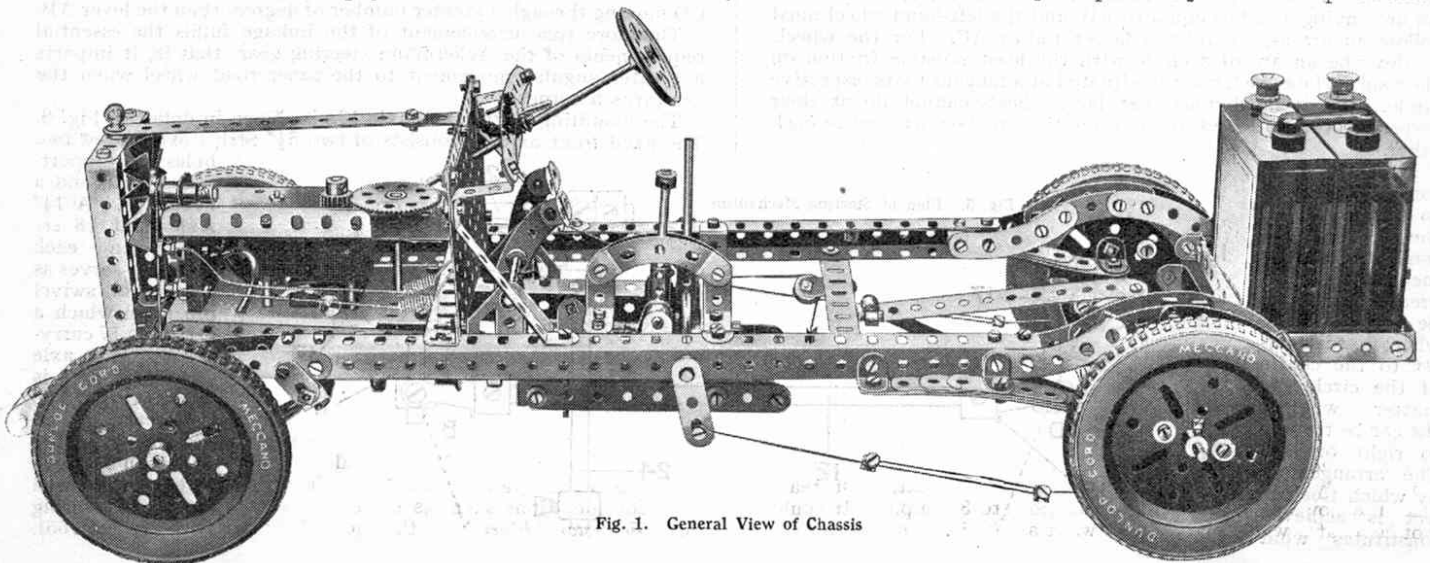
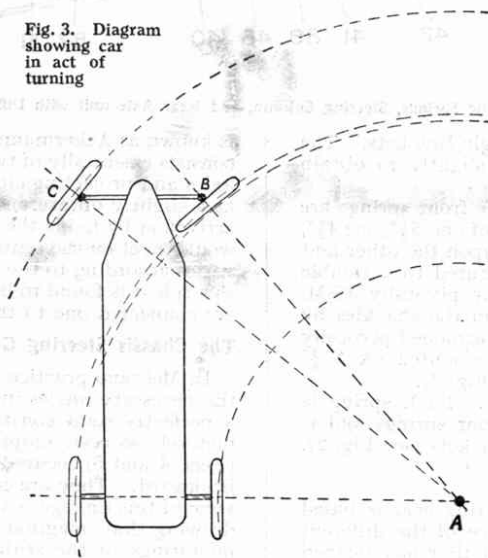

Fig. 1. General View of Chassis

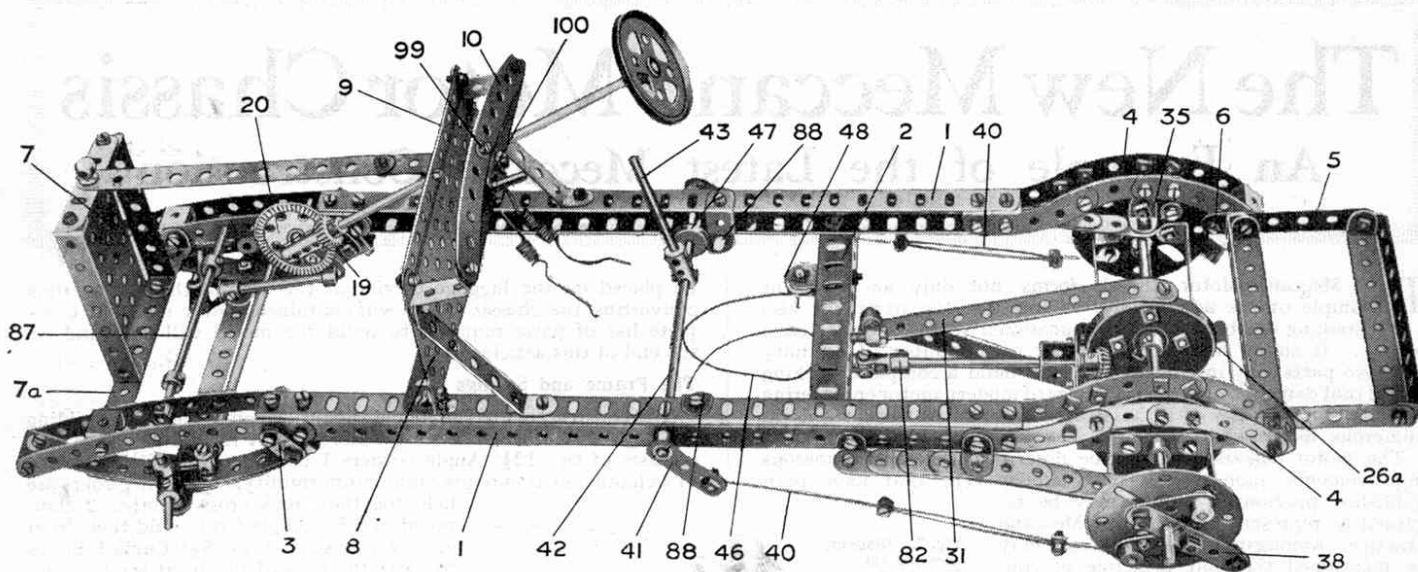

Fig. 2. Frame, showing Springs, Steering Column, and Rear Axle unit with Differential removed

to the Plate 8 by means of two 1" Reversed Angle Brackets. The outer ends of these Brackets should be bent slightly to obtain the correct angle for the dashboard.

It will be seen clearly from Fig. 6 that the front springs are of the semi-elliptic type, and that each consists of one 5½", one 4½", one 3½", one 2½", and one 1½" Strip placed one upon the other and slightly bent. Each end of the 5½" Strip is secured to a Double Bracket. The rear Double Bracket is bolted pivotally (S.M. 262) to the pair of Flat Brackets 3, which form the shackles by means of which the rear ends of the springs are attached pivotally to the frame. The front Double Bracket is mounted on a ¾" Bolt passing through the side frame members (Fig. 4).

The rear springs are of the cantilever type. Each spring is built up from the same components as the front springs and is attached rigidly to the frame by two Angle Brackets (see Fig. 2).

**Principles of Ackermann Steering**

It has already been mentioned that the steering gear is based on the Ackermann principle but the importance of the different angularities of the front wheels may be a point that has escaped the notice of many Meccano boys. Perhaps it will not be out of place, therefore, to insert here a brief summary of the principle of the gear.

When a car turns a corner the near side road wheels describe a sharper curve than the outer wheels. This will be clear on reference to Fig. 3. The drawing is intended to represent a car turning a corner, and in doing so it will be apparent that the wheels must describe an arc or portion of a circle whose centre is shown at A. Now although both front wheels must turn about this centre they are situated at varying distances from it. This means to say that the right-hand front road wheel must follow an arc having a radius equal to AB, and the left-hand wheel must follow an arc struck from a larger radius AC. For the wheels to describe an arc of a circle with the least possible friction on the road surface, each must be situated at a tangent to its respective circle. But it is obvious that both wheels cannot lie at their respective tangents and at the same time remain parallel to each other.

Hence it becomes necessary to incorporate in the steering gear some method by means of which a greater angle can be given to the wheel that is nearest to the centre of the circle, no matter whether the car be turning to right or left. The arrangement by which this object is achieved constitutes what

is known as Ackermann steering gear. In actual practice, the gear consists essentially of two short levers rigidly connected to the stub axles and projecting either forward or backward. These levers lie at a slightly obtuse angle to the stub axles. The correct angle is arrived at by fixing the levers so that their centre lines, if produced, would meet on the centre line of the car. The exact meeting place varies according to the size of the car and length of the levers, but as a rule it is found to be just in front of the back axle. The levers are connected one to the other by a tie rod.

**The Chassis Steering Gear**

In Meccano practice it has been found a little difficult to secure the necessary angles in the levers and at the same time maintain a perfectly rigid construction, and therefore, a slightly different method has been adopted. This comprises short Rods 11 and 11a (Figs. 4 and 5) secured just behind the stub axles and protruding backward. They are connected together by a 5" Rod 12. A plan view of this linkage is shown in Fig. 5, and it will be seen from the drawing that imaginary lines AB, CD drawn through the pivotal mountings of the stub axles and through the points where the tie rod 12 is attached to the rods 11 and 11a correspond roughly to the angles at which the levers would be placed in actual practice.

Now if the car is to be turned to the right when looking at the gearing as in Fig. 5, the road wheel on the stub axle 13 must be deflected in that direction and the imaginary lever AB will be moved through a certain number of degrees to the left. In doing so it pushes the lever corresponding to CD in our sketch in the same direction, but owing to the difference in angularity between the two levers, lever CD and therefore the road wheel attached to its stub axle 13a, moves through a lesser number of degrees. If the car moves to the left exactly the opposite occurs, the lever CD moving through a greater number of degrees than the lever AB.

Therefore this arrangement of the linkage fulfils the essential requirements of the Ackermann steering gear, that is, it imparts a greater angular movement to the inner road wheel when the car turns a corner.

The mounting of the stub axle 13a is shown in detail in Fig. 6. The fixed front axle 14 consists of two 5½" Strips overlapped two

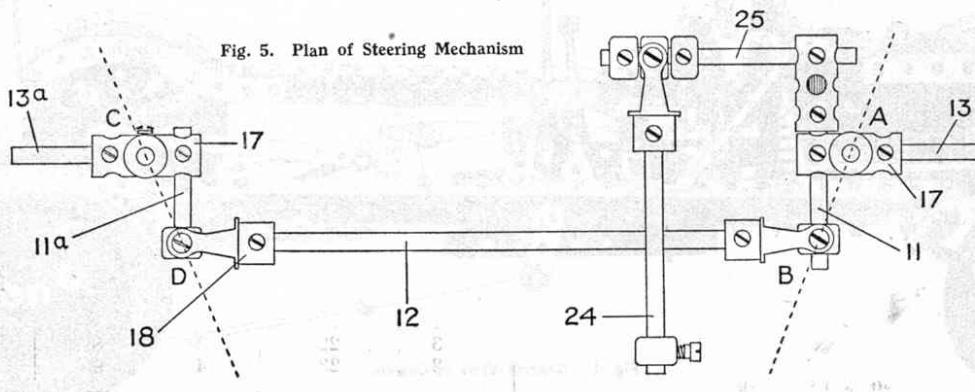

Fig. 5. Plan of Steering Mechanism

holes and supporting at each end a Crank 15. A 1½" Axle Rod 16 secured in each Crank 15 serves as a vertical swivel pin upon which a Coupling 17 carrying the stub axle (a 1" Axle Rod) is free to turn. The Coupling 17 in Fig. 6 carries the 1" Rod 11a, to which is secured a Swivel Bearing 18 (Part No. 165).



The fork of the latter is fixed to the tie rod 12, the other end of which is connected to the other stub axle by another Swivel Bearing secured to the 1 1/2" Rod 11 (Figs. 4 and 5).

The connections between the steering wheel and the road wheels form another important point that must be considered in connection with the steering gear. The gear ratio, or extent of movement of the road wheels to a given movement of the steering wheel, must not be too high, otherwise a slight twist of the wheel would result in a considerable deflection of the car, which would be dangerous and might easily cause accidents. On the other hand, if the ratio is too low the car would be slow to respond to the wheel and therefore difficult to manage in dense traffic. In actual practice the gear reduction is effected in various ways, principally by worm and nut mechanism, but in the Meccano model the most convenient method was found by gearing a 1/2" Bevel 19 with a 1 1/2" Bevel Wheel 20, Fig. 4. The latter is free to turn on a 1 1/2" Rod journalled in the side frame member and secured in the centre of a Coupling 21. One end of this Coupling forms a journal bearing for the end of the steering column 22, which consists of an 8" Rod carrying a 2" Pulley Wheel to represent the steering wheel.

A Flat Bracket 23 bolted to the 1 1/2" Bevel Wheel 20 forms the steering lever, and a set-screw passed through its elongated hole is used to secure a Collar to the 2 1/2" Rod 24. The other end of this Rod 24 carries a Swivel Bearing, the collar of which is free to turn between two Collars and set-screws on the 2" Rod 25. Nuts should be placed on the bolts against the collar of the Swivel Bearing, to hold the bolts rigid without gripping the Rod 25. The latter rod is fixed in a Coupling secured to the 1 1/2" Rod 11. It will now be seen that the movement of the steering wheel is transmitted to the right-hand road wheel via the Bevel Wheel 20 and linkage 24 and 25, and the left-hand wheel is caused to move simultaneously but at a different angle, as has been explained already, by means of the Rods 11 and 11a and tie rod 12.

The fixed front axle 14 is secured to the front chassis springs by means of 3/8" Bolts. The Cranks 15 should be bent so that the fixed swivel pins 16 are slightly out of the vertical, with their upper ends pointing outward. This brings the points of contact between the front wheels and the ground as nearly as possible beneath the centres of the swivel pins. In actual practice the object of canting the swivel pins in this way is to save the driver from fatigue and road shock, for if the centre line of each road wheel was parallel with the centre line of the swivel pin, all shock or vibrations in the road wheel would act on the steering wheel with a leverage equal to the distance that separates them. It is specially important in cars fitted with four-wheel brakes, for the application of such brakes on a car where pin and wheel are parallel would tend to "toe out" the wheels.

The instructions for building the New Motor Chassis will be concluded in next month's "M.M." The second instalment of the article will describe the back axle unit, the transmission gear and differential, etc.

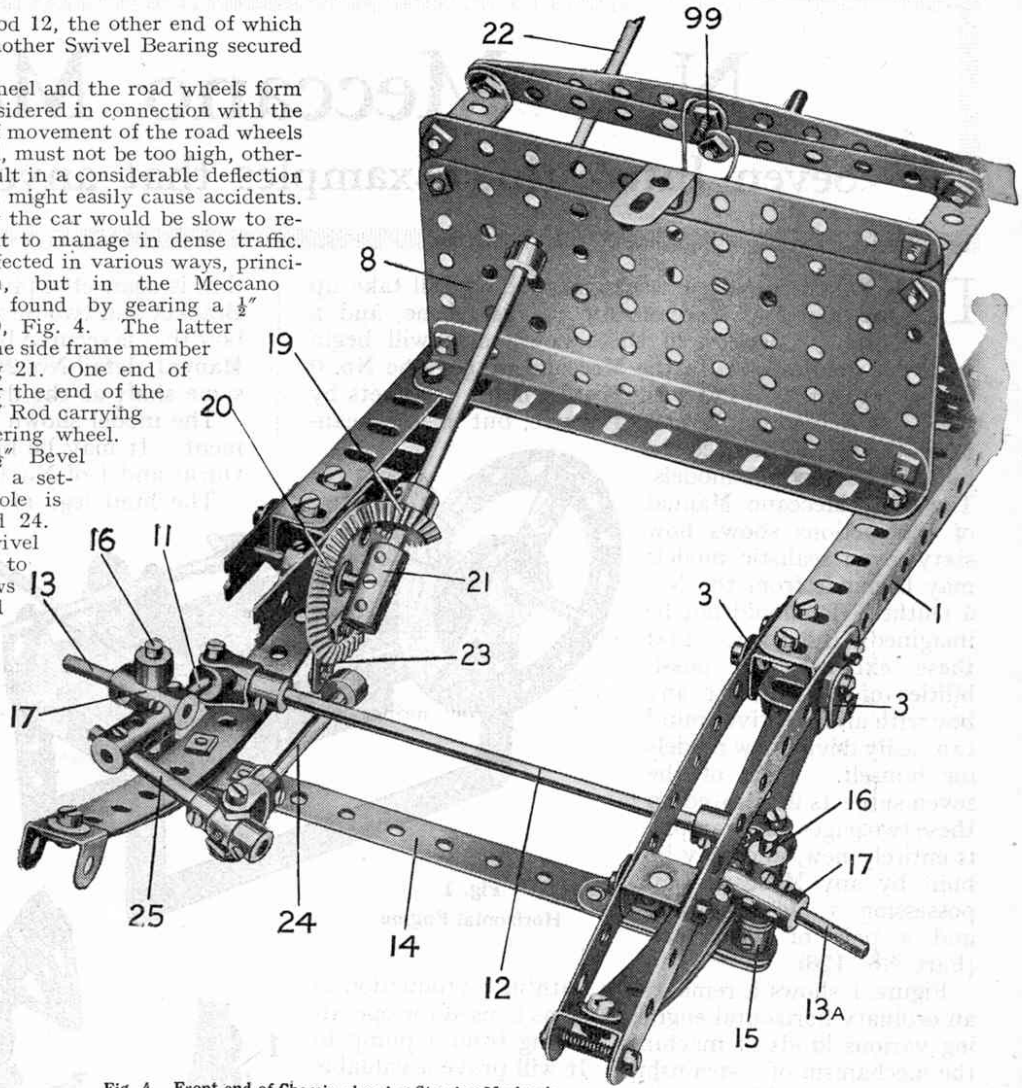

Fig. 4. Front end of Chassis, showing Steering Mechanism

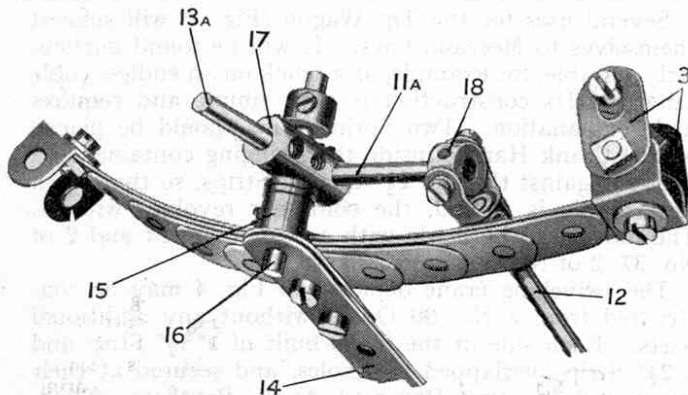

Fig. 6. Detail of Left-hand Stub Axle

### Parts Required

The following is a complete list of the parts required to build the revised Motor Chassis:—

11 of No. 2	1 of No. 23A	2 of No. 90A
9 " " 2A	2 " " 25	4 " " 101
4 " " 3	4 " " 26	1 " " 102
6 " " 4	2 " " 27	2 " " 109
6 " " 5	1 " " 27A	5 " " 111
9 " " 6A	1 " " 28	8 " " 111A
4 " " 8	4 " " 30	9 " " 111C
2 " " 9	2 " " 30A	1 " " 115
12 " " 10	2 " " 30C	2 " " 120B
8 " " 11	4 " " 31	4 " " 124
24 " " 12	178 " " 37	2 " " 125
4 " " 12A	38 " " 37A	2 " " 126
4 " " 12B	40 " " 38	1 " " 136
1 " " 13A	1 " " 45	4 " " 137
2 " " 14	2 " " 46	5 " " 140
2 " " 15	2 " " 47A	4 " " 142B
1 " " 15A	9 " " 48A	2 " " 147B
5 " " 16	2 " " 48B	1 " " 157
2 " " 16A	4 " " 48C	2 6BA Screws
1 " " 16B	1 " " 53	2 6BA Nuts
5 " " 17	1 " " 55A	2 Insulating Bushes
5 " " 18A	3" " 58	2 Insulating Washers
3 " " 18B	42 " " 59	1 Small Rubber Ring
4 " " 19B	5 " " 62	1 4-volt Electric Motor
1 " " 20	9 " " 63	
1 " " 20A	1 " " 70	
3 " " 22	5 " " 89	
2 " " 23	14 " " 90	

# The New Meccano Motor Chassis

## Fine Example of the Latest Meccano Construction

(Concluded from Last Month)

THE back axle, which really consists of a fixed hollow casing, is represented in the model by a framework of Strips, etc., that provides suitable bearings for the two axle shafts and also forms a rigid connection between the fixed portions of the rear wheel brakes (see Fig. 8).

The differential is housed in the back axle between two Wheel Flanges 26 and 26a, each of which is bolted against the inner side of a  $2\frac{1}{2} \times 1\frac{1}{2}$ " Double Angle Strip. These Angle Strips are secured rigidly together by means of 3" Strips 26b, and their centre holes form the inner bearings for the axle shafts 27 and 28. In addition, shaft 28 passes through the centre hole of a  $2\frac{1}{2} \times \frac{1}{2}$ " Double Angle Strip 29 bolted to the Wheel Flange 26a. One Washer should be placed between the Wheel Flange and the Angle Strip 29 on each of the bolts that hold the latter in position. The rear wheel brake mountings consist of two Face Plates 30 bolted rigidly to the back axle casing, one being secured to the ends of two 1" Reversed Angle Brackets and the other to the ends of two  $2\frac{1}{2} \times \frac{1}{2}$ " Double Angle Strips.

### The Torque Rods

The rear axle casing (Fig. 7) performs several important functions in addition to that of providing rigid bearings for the shafts secured to the road wheels. Besides carrying the weight of the vehicle, it must absorb the torque or twisting reaction set up by the propeller shaft, and also transmit the thrust of the road wheels to the chassis. The torque set up in the back axle will be understood more clearly by studying the action of the drive transmission between the propeller shaft and the road wheels. Suppose that this is effected by a bevel pinion on the propeller shaft driving a larger bevel gear secured to an unbroken axle carrying the two road wheels: when the engine rotates, the small bevel pinion on the propeller shaft will endeavour to rotate the bevel wheel on the back axle but since this naturally is somewhat difficult to move, the pinion will tend to travel round the bevel wheel while the latter remains stationary. This state of affairs possibly might result in a snapped propeller shaft and even broken springs, owing to the twisting movement imparted to the axle casing.

It is to counteract these stresses and strains that motor vehicles are fitted with what are known as torque rods. Many car manufacturers obtain the required results by enclosing the propeller shaft in a torque tube, which not only forms a torque reaction resistance, but also receives the forward thrust of the back axle. In the Meccano model the torque rods are shown quite separately from the propeller shaft, so that their functions may be understood more readily.

The torque rods consist of two  $5\frac{1}{2}$ " Strips 31 secured to the ends of the  $2\frac{1}{2} \times \frac{1}{2}$ " Double Angle Strip 29. These  $5\frac{1}{2}$ " Strips taper together at their other ends, where they are secured to a Collar 32 by means of an ordinary bolt inserted in place of the grub screw. Two Washers

should be placed beneath the head of this bolt to prevent its shank from binding on the  $\frac{1}{2}$ " Bolt 33, about which the Collar is free to pivot. The latter bolt, in turn, is inserted in another Collar 34 that is capable of turning about a Pivot Bolt secured to the  $5\frac{1}{2}$ " Girder 2, which forms the main cross member of the frame (see Fig. 2). A Compression Spring (part No. 120b) is placed between the Collar and the Girder

to act as a shock absorber when the back axle is forced up and down by irregularities in the road surface.

It will now be seen that the torque rods 31 effectively counteract any twisting tendency in the back axle without interfering with the free vertical movement of the latter as a whole or the independent movement of one or other of the rear wheels.

The back axle casing is secured to the rear cantilever springs by an Angle Bracket 35 secured to each Face Plate 30. These Angle Brackets are bolted to the end holes of the springs, as will be seen in Fig. 2.

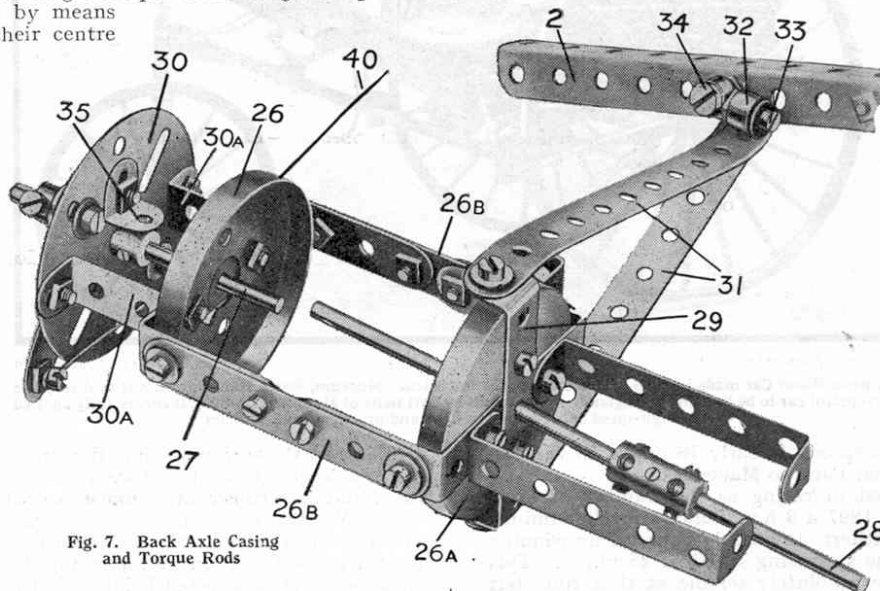

Fig. 7. Back Axle Casing and Torque Rods

### Brake Mechanism

One of the rear wheel brakes is shown in detail in Fig. 8, and it will be seen that it is of the internal expanding type. Two  $\frac{1}{2}$ " Bolts are passed through opposite slots in the Face Plate 30 and their ends, after passing through  $1\frac{1}{2}$ " Strips 36, are secured in Collars 37, which form the brake shoes. Each  $\frac{1}{2}$ " Bolt carries a Washer under its head and two on its shank between the Face Plate and the  $1\frac{1}{2}$ " Strips 36. The latter Strips are pivoted by means of bolts and lock nuts to a  $2\frac{1}{2}$ " Strip 38 that is free to turn about the axle shaft 27. When the  $2\frac{1}{2}$ " Strip is moved, the Collars are thrust outward along the slots by means of the links 36 and pressed against the inside periphery of a Wheel Flange 39 bolted to the inside of the road wheel. Three Washers should be placed on the axle 27 between the Strip 38 and the Face Plate. Care should be taken to see that the  $\frac{1}{2}$ " Bolts are able to move quite freely to and fro in the slots of the Face Plate.

The grub screws in the Collars 37 have been replaced by  $7/32$ " Meccano Bolts, and these are used to secure a short length of Spring Cord. The latter serves to withdraw the brake shoes 37 and return the brake to the "off" position when the Strip 38 is released. The road wheel should be placed on the axle 27 with the Wheel Flange 39 towards the Collars 37, care being taken to see that the latter have plenty of room to move before the road wheel is secured rigidly to the axle.

Each brake rod 40 (see Figs. 2 and 8) consists of two Meccano loom Healds bolted together (a length of cord will serve almost as well in their place if preferred). The Healds are connected pivotally at one end to the Strip 38 by means of a bolt and two nuts (see S.M. 262) and at the other end by a similar method to a

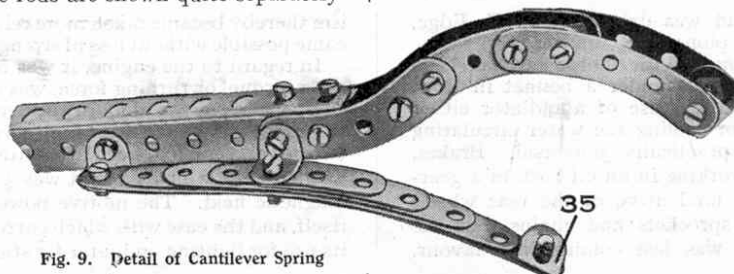

Fig. 9. Detail of Cantilever Spring



Crank 41 secured to a 6½" Rod 42 (Fig. 2). This Rod 42 carries a hand lever 43 (a 2½" Rod) by means of which the brakes are operated.

A second brake is fitted to the chassis and is operated by the foot pedal 44, the mounting of which is clearly shown in the general view of the power unit (Fig. 10). It will be seen that the lever consists of a 2½" large radius Curved Strip pivoted by its centre hole to a 3½" Rod 45 journalled in two Trunnions. A length of cord 46 (Figs. 2 and 10) is tied to the second hole of the lever and is led under the ½" loose Pulley 47 (Fig. 2), round a second ½" Pulley 48 (mounted on a Pivot Bolt secured in the end of a Single Bent Strip bolted to the cross member 2) and thence round the groove of a 1" Pulley 49 (Fig. 10) secured to the cardan shaft. The cord is finally brought back and tied under the head of the Pivot Bolt carrying the Pulley 48. A slight pressure on the pedal 44 tightens the cord round

a 1" fast Pulley 57, a 1½" Contrate Wheel 58, and a 1" fast Pulley 59 (Fig. 11). A length of cord connects the Pulley 57 with the ½" fast Pulley 60 (Fig. 10) secured to the shaft of the radiator cooling fan, which is free to rotate in the boss of a Crank 61. The latter is bolted by its end hole to an Angle Bracket secured to the top of the Motor. When the engine is in motion the fan rotates at a considerable speed immediately behind the radiator.

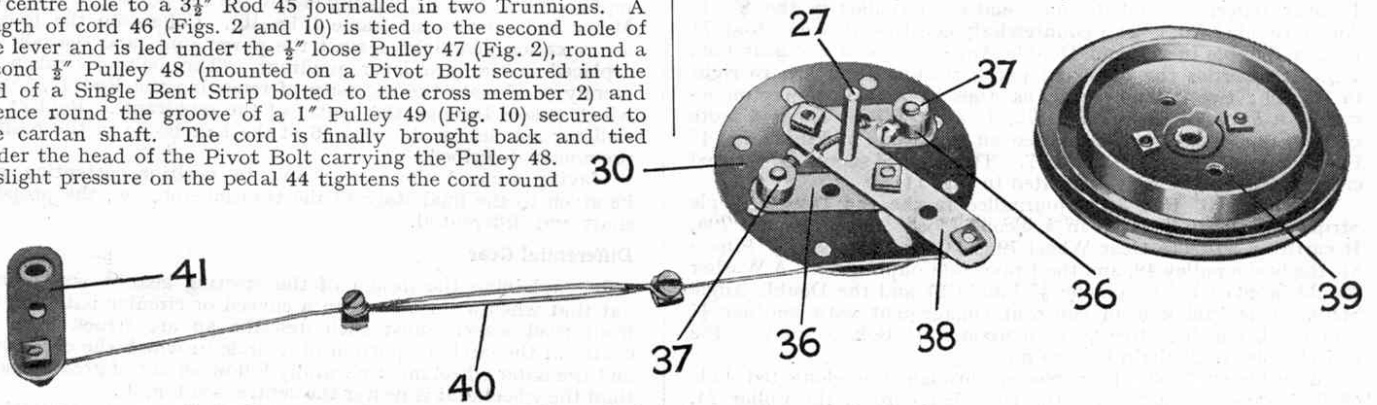

Fig. 8. Internal-expanding Rear Wheel Brake, ready for assembly. The road wheel is shown separately on the right

the Pulley 49 and thereby retards the motion of the cardan shaft. When the brake is off the lower portion of the pedal rests against a ¾" Bolt 50 secured in one of the Trunnions, and the pedal is held thereby in a convenient upright position.

**The Power Unit**

The 4-volt Electric Motor representing the engine, and the gear box, clutch, etc., are all rigidly connected together, so that they form a complete unit that may be removed from the chassis simply and quickly. This method of construction ensures that the gear wheels and other working parts will always be in proper alignment with each other, and that their functions will not be affected in any way by stresses and strains set up in the chassis frame.

The main frame of the unit consists of two 9½" Angle Girders 51 connected together by two 2½" x ½" Double Angle Strips 52 and a 4½" Strip 53. The Motor is secured to the frame by a bolt passing through hole A in its side and hole B in the 3½" Strip 54, and by two other bolts engaging the holes C and D of one of the 9½" Girders. A Washer is placed on each of these bolts between the Motor and the frame. It will be observed that the Motor rests on the far side 9½" Angle Girder (Fig. 10) only, and is bolted thereto. The near 9½" Angle Girder is not attached to the Motor except by the 3" Strip 54.

A 2½" x ½" Double Angle Strip bolted across the two Double Angle Strips 52 forms a bearing for the 5" Rod 56, which corresponds to the crankshaft of an actual car. This Rod 56 carries

**Transmission—The Clutch**

The drive from the Motor armature is first led to a secondary shaft 62, on the lower end of which is secured a ½" Pinion, boss downward, engaging with the 1½" Contrate Wheel 58. The 1" Pulley 59 on the 5" Rod 56 forms the male portion of the clutch (Fig. 11) and is fitted with a Meccano Rubber Ring (Part No. 155), which provides the resilient surface required in a frictional contact clutch of this type. The female clutch member consists of a Flanged Wheel 63, with set-screw removed, placed on the end of a 3½" Rod 64.

The Flanged Wheel must slide on the Rod 64 and yet be mounted in such a way that when it is engaged by the clutch member 59 it transmits power to the Rod 64. This is accomplished in the following manner: two Angle Brackets bolted to the Flanged Wheel by ¾" Bolts and spaced therefrom by Collars engage by their slotted holes with the shanks of two set screws inserted in the "spider" or central collar 65 of a Universal Coupling. This "spider" is secured to the Rod 64 and a portion of a Compression Spring 65a (part No. 120b) is inserted between it and the boss of the Flanged Wheel. For this purpose it will be necessary to cut the spring approximately in half. The Spring 65a normally holds the Flanged Wheel in engagement with the Rubber Ring on the Pulley 59, but the Flanged Wheel can be forced back on the Rod 64 to an extent just sufficient to throw it out of gear with the clutch member 59.

The clutch withdrawal mechanism consists of a 2" Slotted Strip

66 (Fig. 10) bolted to a 1½" Strip, the latter in turn being bolted to a 1" x ½" Angle Bracket 67 that is connected by a bolt and lock-nuts to the second hole of the pedal 55. The slot of the Strip 66 engages the Rod 62 immediately behind the Pinion driving the Contrate Wheel 58. The Rod 62 thus forms a guide for the Strip 66, which moves in a direction parallel to the Rod 56. It will be found that when the pedal 55 is depressed the shank of the bolt 66a engages with the rim of the Flanged Wheel 63, and the latter is thereby withdrawn from contact with the clutch member 59.

**Gear Box**

The gear box provides three speeds

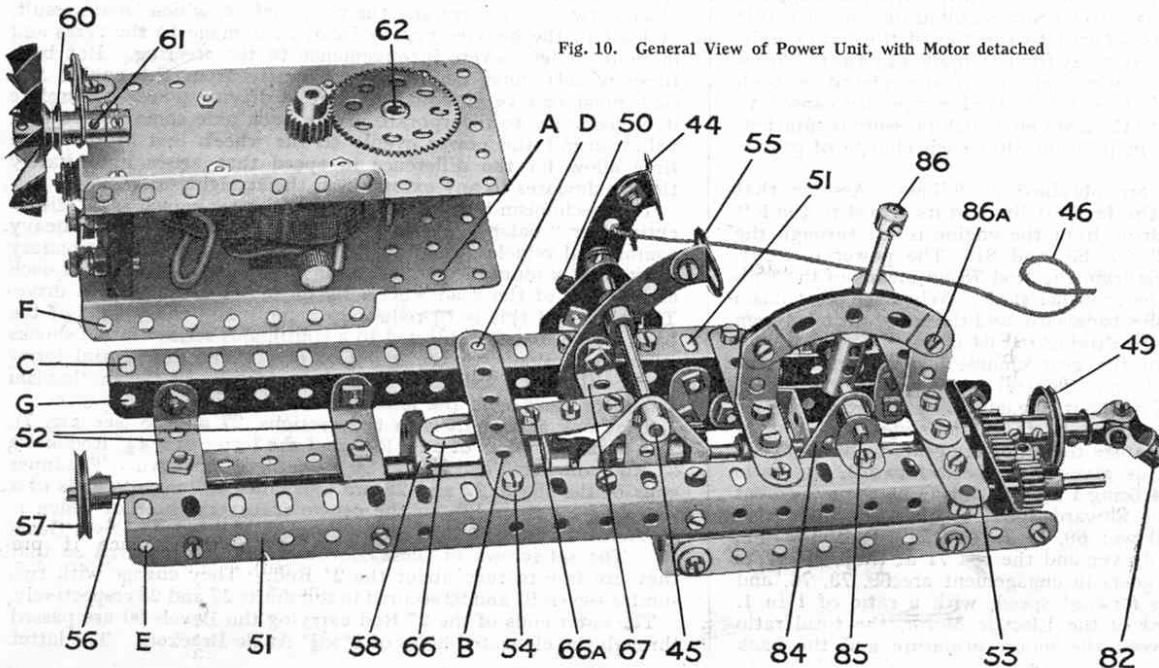

Fig. 10. General View of Power Unit, with Motor detached

forward, neutral, and reverse gears. It is built up from two  $4\frac{1}{2}$ " Strips connected together at the front end by a  $2\frac{1}{2}$ " $\times$ 1" Double Angle Strip and at the other end by a  $2\frac{1}{2}$ " $\times$  $\frac{1}{2}$ " Double Angle Strip (Fig. 11). It is bolted to the Angle Girders 51 in the position shown in Fig. 10 by means of four Flat Brackets.

The  $3\frac{1}{2}$ " Rod 64 carrying the clutch member represents the primary driving shaft. It is provided with a  $\frac{3}{4}$ " Pinion 68 and a 1" Gear Wheel 69, and its inner end is journalled in the  $1$ " $\times$ 1" Angle Bracket 70. The countershaft consists of a  $6\frac{1}{2}$ " Rod 71 that is slidable in the end Double Angle Strips of the gear box. This Rod carries the following parts, reading from left to right in Fig. 11: two Collars (acting as stops to limit its sliding movement), a 50-teeth Gear Wheel 72, 1" Gear Wheel 73, two more Collars, one of which (74) is free on the Rod,  $\frac{3}{4}$ " Pinion 75, 1" Gear Wheel 76, and  $\frac{1}{2}$ " Pinion 77. These parts should be secured carefully in the positions indicated in Fig. 11.

The driven  $3$ " Rod 78 is journalled in the end Double Angle Strip of the gear box and in a second  $1$ " $\times$ 1" Angle Bracket 70a. It carries a 50-teeth Gear Wheel 79, 1" Gear Wheel 80,  $\frac{1}{2}$ " Pinion 81, the brake pulley 49, and the Universal Coupling 82. A Washer should be placed between the  $\frac{1}{2}$ " Pinion 81 and the Double Angle Strip. This Pinion is in constant engagement with another  $\frac{1}{2}$ " Pinion 83, which is free to turn upon a  $\frac{3}{4}$ " Bolt secured to the end Double Angle Strip by two nuts.

An ordinary  $7/32$ " Bolt passes through the elongated hole of the Crank 84 and enters the threaded bore of the Collar 74. A nut placed upon it is secured tightly against the Collar in order to prevent its shank touching the rod 71 and also to ensure that the Crank is quite free to pivot about the bolt. The Crank is secured to a 2" Axle Rod 85 (Fig. 10) journalled in Angle Brackets

road wheels is fairly considerable.

The power unit is mounted in the chassis as follows. First remove the radiator by unscrewing the Strip 7a (Fig. 2) on which it is mounted; remove the bolt 86a (Fig. 10) from the change gear lever quadrant, and draw out the 5" Rod 87 (Fig. 2). Now place the power unit in position and bolt the end holes of the  $4\frac{1}{2}$ " Strip 53 to the  $\frac{1}{2}$ " Reversed Angle Brackets 88 (Fig. 2), and replace the 5" Rod 87, passing it through the holes E, F, G, of the Motor and power unit frame (Fig. 10). Collars on the Rod 87 are next screwed tight against the power unit, and the bolt 86a replaced in the gear lever quadrant. (This bolt was taken out merely to obviate the necessity of removing the Rod 42, Fig. 2, which passes through the centre of the quadrant). Replace the radiator and secure the cord 46 of the foot brake in the position previously described.

Having secured the power unit in position, attention may be given to the final stage in the transmission, i.e., the propeller shaft and differential.

### Differential Gear

In explaining the design of the steering gear it was pointed out that when a car travels in a curved or circular path the two front road wheels must each describe an arc struck from the centre of the circle or portion of a circle in which the car moves, and the outer wheel must naturally follow an arc of greater radius than the wheel that is nearer the centre (see Fig. 3).

The difference in speed thus set up between the two wheels is not important in the case of the front wheels, for they are both free to turn on their individual axles; but it is obvious that since the rear or driving wheels are similarly placed in regard

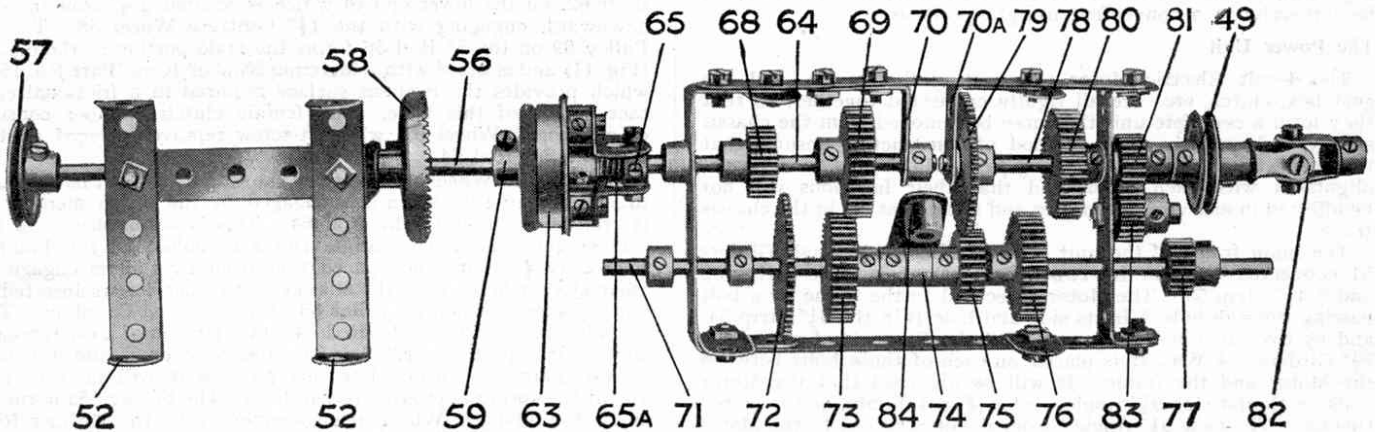

Fig. 11. Gear Box and Clutch

bolted to the Angle Girders 51 of the power unit, and a Coupling secured to this Rod carries the gear change lever 86.

It will be seen that the lever moves in a quadrant constructed from two  $2\frac{1}{2}$ " small radius Curved Strips bolted one on each side of  $1$ " $\times$ 1" Angle Brackets secured to the top of the power unit. The Curved Strips are spaced away from each other by the thickness of the supporting Angle Bracket and one Washer placed on each connecting bolt. In this way the Curved Strips are caused to apply a certain pressure to the lever 86, which pressure is sufficient to hold the lever firmly in position after each change of gear is effected.

The different speeds are obtained as follows. Assume that the sliding rod 71 is at the furthest limit of its travel to the left in Fig. 11. Then the drive from the engine is led through the following gears: 68, 72, 77, 83, and 81. The power is transmitted to the road wheels from the Rod 78 by means of the Universal Coupling 82 and the propeller shaft. When the mechanism is so placed the chassis runs backward, and the speed ratio between the propeller shaft and the driving rod 64 is 1 in 2.

A slight movement of the gear change lever disengages the Pinion 77 from Pinion 83, and "neutral" gear results, the secondary shaft revolving idly without engaging any of the wheels 79, 80 or 83. Further movement of the lever slides the Rod 71 further to the right and causes the following gears to be engaged: 68, 72, 75, and 79. This gives first speed forward, the ratio between shafts 78 and 64 being 1 in 4. Continuing the movement of the lever, the second forward speed is obtained, the drive now being directed as follows: 69, 73, 75, and 79. Ratio: 1 in 2.

When the lever is hard over and the rod 71 at the limit of its travel to the right, the gears in engagement are 69, 73, 76, and 80. This represents top forward speed, with a ratio of 1 in 1. Owing to the high speed of the Electric Motor, the total ratio of speed reduction between the motor armature and the back

to the central point A, Fig. 3, the same rule must apply to them. To state this more plainly, the rear wheels must rotate at different speeds when the car moves in a curve, otherwise slip must take place between the tyres and the road surface, which would result, at least in the heavier types of car, in damage to the tyres and in more or less severe inconvenience to the steering. But both these wheels must be driven constantly from the engine and each must receive an equal amount of driving power; therefore it is necessary to incorporate in the back axle some device that will transmit the power evenly to the wheels and at the same time allow for the difference in speed that arises immediately the car deviates to any extent from the straight.

The mechanism that fulfils these functions is known as a "differential" or "balance" gear. In some cars, especially in heavy commercial vehicles, the differential is incorporated in a secondary shaft that is journalled in the main frame and connected at each end to one of the road wheels by means of chain or belt drive. The object of this is to reduce to a minimum the weight of the back axle, which is subjected to a continuous series of road shocks when in motion. In the Meccano model, the differential forms part of the back axle unit, and the principles of the mechanism should be clear from the following description.

The back axle shaft is in two sections, 27 and 28 (see Fig. 7). The former consists of a 3" Rod and the latter of a  $4\frac{1}{2}$ " Rod and a 2" Rod connected end to end by a Coupling as shown. The inner ends of the shafts 27 and 28 are journalled in opposite ends of a Coupling 89 (Fig. 12), in the centre transverse hole of which is secured a 2" Rod 93 that serves to carry the two  $\frac{3}{4}$ " Bevel Gears 90. The set-screws of these Bevels should be removed so that they are free to turn about the 2" Rod. They engage with two similar Bevels 91 and 92 secured to the shafts 27 and 28 respectively.

The outer ends of the 2" Rod carrying the Bevels 90 are passed through the elongated holes of  $1$ " $\times$  $\frac{1}{2}$ " Angle Brackets. The latter



are secured rigidly by means of  $\frac{1}{2}$ " Bolts to opposite holes in the  $1\frac{1}{2}$ " Bevel Gear 94, and are spaced therefrom by means of Collars placed upon the bolts between the Brackets and the Bevel Gear. This Bevel Gear is free to revolve independently about the axle shaft 28, its set-screw having been removed.

The propeller shaft consists of a  $3\frac{1}{2}$ " Rod 95, one end of which is secured in the Universal Joint 82 (Fig. 11) and the other end, after passing through a Double Bent Strip and the side of the differential frame, is secured in the  $\frac{1}{2}$ " Bevel Gear 96, which engages with the  $1\frac{1}{2}$ " Bevel Gear 94. Two Collars 98 should be secured to the shaft 28 in the position shown to maintain the various gears in correct alignment and to prevent the gears 94 and 96 from slipping or binding against each other. A Washer should be placed between the outer Collar 98 and the Double Angle Strip forming the end of the differential frame, and two Washers should be placed against the boss of the  $\frac{7}{8}$ " Bevel Gear 91.

Care should be taken to see that the various parts of the differential gear work quite freely and that the several Bevel Gears are all placed in the correct positions in relation to each other. Everything should operate smoothly and easily when the shafts 27 and 28 are twisted between thumb and finger, whether simultaneously and in the same direction, or separately and in opposite directions.

If one of the road wheels revolves at a greater speed than the other the Bevel Gears 90 begin to rotate and thereby adjust the difference in speed between the Bevel Gears 91 and 92. If the vehicle is running in a perfectly straight course the axles 27 and 28 and Bevel Gears 90, 91 and 92 must all rotate as one unit, since the road wheels are travelling at the same speed.

The construction of the differential frame will be obvious from Fig. 12. The two  $2\frac{1}{2}$ " x  $1\frac{1}{2}$ " Double Angle Strips shown in this illustration may also be seen in Fig. 7, but in the latter case they are shown bolted to Wheel Flanges 26 and 26a and incorporated in the back axle casing. When the gear is ready to assemble, the differential frame (formed by the  $2\frac{1}{2}$ " x  $1\frac{1}{2}$ " Double Angle Strips and 3" Strips 26b) should first be incorporated in the fixed back axle (Fig. 7). The gearing should then be placed in the frame and the shafts 27 and 28 inserted in their respective positions. It will be noticed that a Washer is placed beneath the head of the bolts at each corner of the differential frame (Fig. 12); this is to prevent the shanks of the bolts fouling the sides of the Wheel Flanges 26 and 26a (Fig. 7).

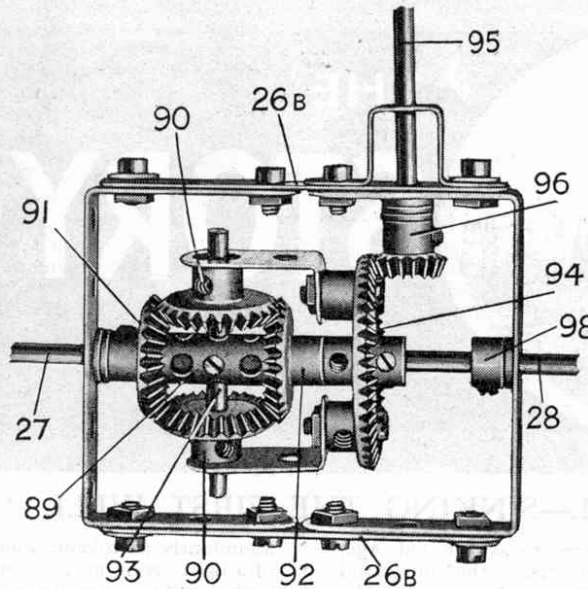

Fig. 12. The New Differential Gear

Electrical Connections

All that now remains to complete the model is the wiring between the Motor, dashboard switch, and the Accumulator. Either the Meccano 8 amp. or 20 amp. Accumulator may be used, but the former is of a more convenient size. As previously pointed out, it may be mounted on the luggage carrier at the rear of the model.

One wire should be led direct from the Motor terminal to one terminal of the Accumulator, and another wire should be led from the second Motor terminal to a 6BA bolt 99 secured to the dashboard (see Figs. 2 and 4). This bolt is insulated from the  $5\frac{1}{2}$ " Curved Strip of the dashboard by means of a Meccano Insulating Bush and Washer. The switch handle consists of a Threaded Pin secured to a Flat Bracket 100, which is attached to the dashboard by another 6BA Bolt. An ordinary metal Washer should be placed on each side of the Flat Bracket, but the bolt is insulated from the dashboard by means of an Insulating Bush and Washer. A wire secured

to its shank is led to the second terminal of the Accumulator. The Motor is started by sliding the Flat Bracket 100 over the head of the bolt 99, thus completing the electric circuit.

In connecting up the wiring care should be taken to see that the insulation is not damaged in any way, otherwise short circuits may be caused by the current leaking to the metal frame of the chassis.

It is scarcely necessary to add that all the working parts of the Chassis, with the single exception of the actual frictional surfaces of the clutch, should be lubricated at frequent intervals. Great care should be taken to prevent any oil coming in contact with the Rubber Ring on the clutch member 59 (Fig. 11), for the oil would cause the clutch to slip, of course, without transmitting the drive to the road wheels.

If the Meccano Chassis is to be used for demonstrating the actual working of a motor car, it will obviously be inconvenient to allow the model to run about on its wheels. A good plan, therefore, is to jack up the model on suitable supports. A stand for this purpose can easily be devised by any boy from ordinary Meccano parts.

When the Chassis is raised in this way, with the wheels free to revolve, the various features of the mechanism may be studied while actually in motion and the different movements, such as starting and stopping the Motor, clutching and declutching, gear-changing, reversing, and steering, etc., may be easily demonstrated.

Answers to

Last Month's Puzzles

No. 1. Hebrew.

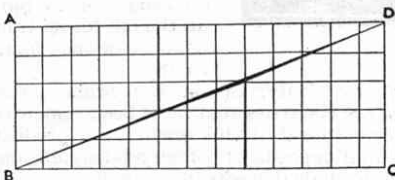

No. 2. When the four pieces are fitted together the two angles that come together at B are together slightly less than a right angle. The same is true of D. Consequently, a space equal in area to one small square is left out of the rectangle. The space is so narrow that it does not become apparent on refitting the pieces of the square. In order to show the solution the drawing above is given in slightly exaggerated form.

No. 3. Lard, tea, butter, ink, bread, salt, beef, pen, wax, pins, fish, candles, button, matches, ham.

No. 4. Time and tide wait for no man.

No. 5. Winchester.

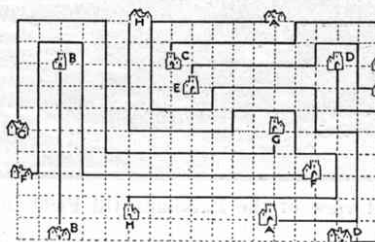

No. 6. The solution to the motorists' problem is given in the above diagram.

No. 7. 116.

No. 8. The completed sum read as under:

215	37195	173
215		
1569		
1505		
-----		
645		
645		

No. 9. Aberdeen, London, Dublin, Dundee, Portsmouth, Hull, Glasgow, Halifax, Wick, Hawick.

An Interesting Railway Booklet

Readers who were interested in the description in the September "M.M." of the Romney Hythe and Dymchurch Railway will be glad to learn that the Locomotive Publishing Co. (3, Amen Corner, London, E.C.4) have prepared an interesting souvenir booklet dealing in detail with this fascinating miniature line. The booklet is illustrated by a series of excellent photographs, including one of the Duke of York driving the "Pacific" type engine "Green Goddess" out of New Romney Station in August last year. The price of the booklet is 1/2 post free.

"MECCANO MAGAZINE" SPRING BACK BINDER



There is no better way of keeping your Magazines clean and tidy than by binding them in one of the special binders we supply. These binders have strong stiff backs, covered with black imitation leather, tastefully tooled, and are lettered in gold. The large binder holds 12 Magazines — price 3/6 post free. The small binder holds 6 or 8 Magazines — price 3/- post free. Meccano Ltd., Binis Road, Liverpool.