

The Lighter Side of Model-Building

Two Amusing Meccano Games

THIS month we make an interesting departure from the usual types of Meccano engineering subjects, and it is hoped that the following two examples will give model-builders some ideas for models of a similar nature. The first model to be described, a Bagatelle Table, is built with Outfit H; and the second, a Shooting Game, with Outfit G. The Meccano Steel Balls used with each model are not included in either of these Outfits but may be purchased separately.

The Bagatelle Table shown in Figs. 1 and 2 is similar to many found in amusement parks. Although the model is not entirely automatic it is extremely interesting, and will prove absorbing even to the oldest Meccano enthusiasts.

Commence the model by building a board as shown in Fig. 1. Each end of this consists of a $12\frac{1}{2}$ " Angle Girder and these are joined together by two side members 1 and 2. The member 1 consists of two $9\frac{1}{2}$ " Angle Girders overlapped one hole and the member 2 is formed from two $12\frac{1}{2}$ " Angle Girders arranged as shown in the illustration. A $5\frac{1}{2}$ " Angle Girder 3 is secured to the bottom of the board and a further $12\frac{1}{2}$ " Angle Girder 4 is bolted parallel to the side members as shown.

A slot is formed immediately in front of the Girder 3 by bolting in place a $5\frac{1}{2}$ " \times $2\frac{1}{2}$ " Flat Plate to one end of which is fitted a $5\frac{1}{2}$ " \times $3\frac{1}{2}$ " Flat Plate. A $12\frac{1}{2}$ " Angle Girder 5 supports the inner ends of these Plates and also one end of three $12\frac{1}{2}$ " \times $2\frac{1}{2}$ " Strip Plates 6, 7 and 8. Two $4\frac{1}{2}$ " \times $2\frac{1}{2}$ " Flat Plates, overlapping two holes, are also supported at one end by the Girder 5. The Plates 6, 7 and 8, together with a $5\frac{1}{2}$ " \times $2\frac{1}{2}$ " Strip Plate 9, are supported at their centres and ends by two more $12\frac{1}{2}$ " Angle Girders, portions of which can be seen in Fig. 1. The upper end of the board consists of two $5\frac{1}{2}$ " \times $3\frac{1}{2}$ " Flat Plates and one $2\frac{1}{2}$ " \times $2\frac{1}{2}$ " Strip Plate.

The positions of the 12 holes are shown in the photograph and the spaces between these are filled in by means of $5\frac{1}{2}$ " \times $2\frac{1}{2}$ ", $2\frac{1}{2}$ " \times $1\frac{1}{2}$ " and $2\frac{1}{2}$ " \times $2\frac{1}{2}$ " Flexible Plates. Small squares of paper are pasted below the holes and on these suitable scores are printed.

The two top holes on each side of the board are "backed"

with pairs of $\frac{1}{2}$ " \times $\frac{1}{2}$ " Angle Brackets, the centre third hole down being similarly fitted. In the centre of the board two Flat Brackets are fitted and raised slightly by means of Washers. The angle of these Brackets can be arranged to suit individual ideas as also

can the various Curved Strips and bolt heads. By altering these Strips, etc., certain holes can be made very difficult to enter and the scores raised accordingly.

A 2" Strip 10 is attached to one of the upper $5\frac{1}{2}$ " \times $3\frac{1}{2}$ " Flat Plates and this is so arranged that a ball on striking it rolls into the second hole down in the centre.

The placing of the $2\frac{1}{2}$ " large and small Curved Strips is shown clearly in the illustration. A $5\frac{1}{2}$ " and $2\frac{1}{2}$ " Strip, bolted together and overlapped two holes, are secured to an Angle Bracket 11 and this compound strip guides the Steel Balls into the slot behind the Girder 3.

The spring plunger for firing the Balls is built up in the following way. A $2\frac{1}{2}$ " \times $\frac{1}{2}$ " Double Angle Strip 12 is fitted between the side member 2 and Girder 4, and it carries a sliding Rod, on the inner end of which is locked a Collar. The outer end of the Rod carries a Collar and $\frac{1}{2}$ " fast Pulley,

the Collar being fitted with a $\frac{3}{8}$ " Bolt carrying one end of a Spring. The opposite end of this Spring is bolted to the side member 2.

It is a good plan to line the inside of the channel, carrying the spring plunger, with strong paper, as this prevents the Balls from stopping before they reach the end of the channel.

Below the board is fitted a sloping surface by means of which the Steel Balls are returned to the opening 13 ready for being used again. An underneath view of this sloping surface is shown in Fig. 2. Each side member consists of a $12\frac{1}{2}$ " and a $7\frac{1}{2}$ " Angle Girder. The Girders of the near side member in Fig. 2 are overlapped four holes, but those forming the other member are overlapped five holes. This extra overlap of one side member

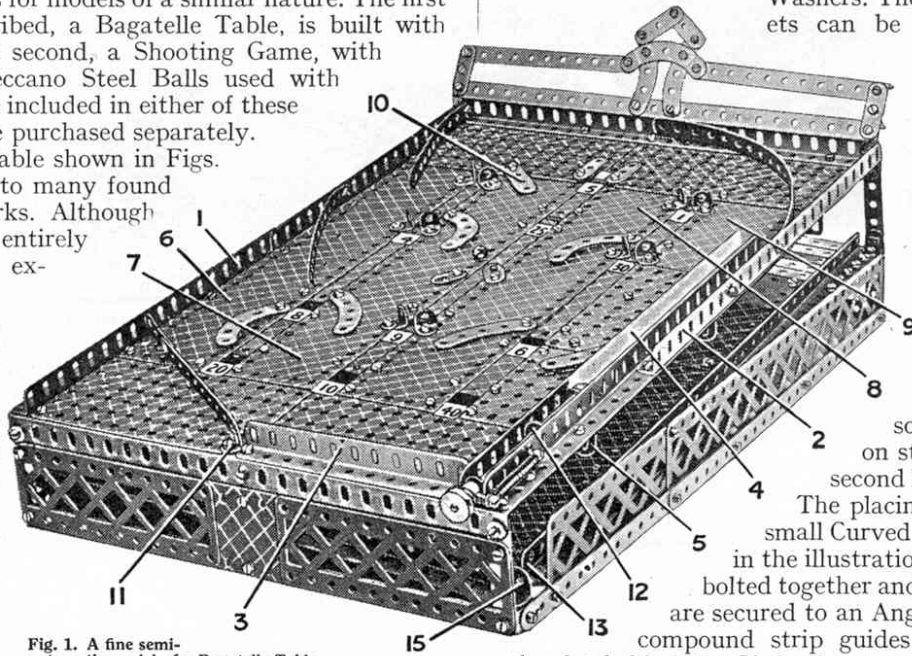

Fig. 1. A fine semi-automatic model of a Bagatelle Table.

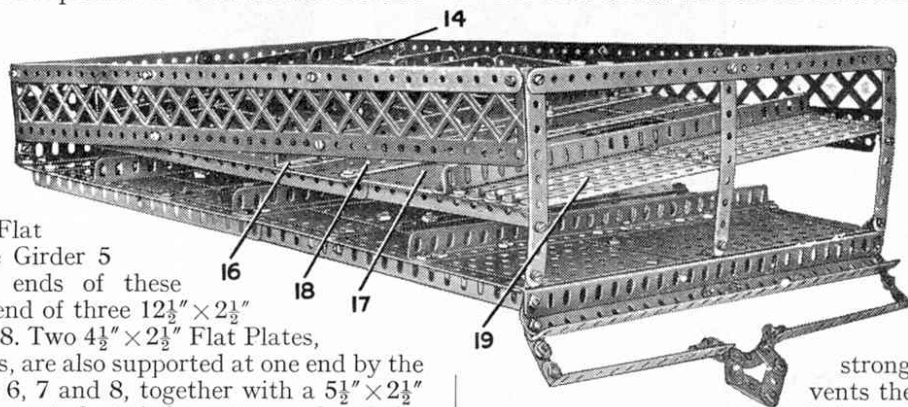

Fig. 2. An underneath view of the Bagatelle Table showing the sloping return surface.

is necessary in order to form the opening 13.

The end of the sloping surface nearest the operating end of the model consists of five $3\frac{1}{2}'' \times 2\frac{1}{2}''$ Flanged Plates 14 secured edge to edge by a $12\frac{1}{2}''$ Angle Girder 15, Fig. 1. The other edges of these Plates are bolted to a $12\frac{1}{2}'' \times 2\frac{1}{2}''$ Strip Plate that is in turn secured to four $5\frac{1}{2}'' \times 2\frac{1}{2}''$ Flanged Plates and one $5\frac{1}{2}'' \times 3\frac{1}{2}''$ Flat Plate. The end flanges of these last mentioned Flanged Plates are secured to a $12\frac{1}{2}''$ Angle Girder 16, and the unoccupied flange of this is then fitted with five $5\frac{1}{2}'' \times 2\frac{1}{2}''$ Strip Plates 17. A $12\frac{1}{2}''$ Strip 18 prevents these Plates from buckling. The sloping surface is completed by the addition of a $12\frac{1}{2}''$ Angle Girder and five $12\frac{1}{2}''$ Strips 19.

The parts required to build the Bagatelle Table are: 6 of No. 1; 1 of No. 1b; 3 of No. 2; 3 of No. 2a; 5 of No. 5; 1 of No. 6; 6 of No. 6a; 14 of No. 8; 2 of No. 8a; 2 of No. 8b; 3 of No. 9; 2 of No. 10; 21 of No. 12; 2 of No. 12c; 1 of No. 15; 1 of No. 23a; 200 of No. 37; 5 of No. 37a; 24 of No. 38; 1 of No. 43; 1 of No. 48a; 4 of No. 52; 4 of No. 52a; 5 of No. 53; 2 of No. 53a; 2 of No. 59; 1 of No. 70; 5 of No. 90; 4 of No. 90a; 4 of No. 99; 2 of No. 100; 5 of No. 111c; 2 of No. 188; 1 of No. 189; 3 of No. 190; 2 of No. 191; 1 of No. 193; 6 of No. 195; 4 of No. 197.

The construction of the Meccano Shooting Game should prove easy if the instructions are followed carefully.

Each side of the base is built up from two $12\frac{1}{2}''$ Angle Girders overlapping two holes. At one end the upturned flange of each compound girder carries a $5\frac{1}{2}'' \times 2\frac{1}{2}''$ Flanged Plate connected together top and bottom by means of $12\frac{1}{2}''$ Angle Girders 1 and 2, Fig. 3.

At the opposite end the sidemembers are secured together by a $12\frac{1}{2}''$ Angle Girder and at each end of this are fitted two $5\frac{1}{2}''$ Strips. One of these Strips is arranged to extend $\frac{1}{2}''$ above the other as shown. A $12\frac{1}{2}'' \times 2\frac{1}{2}''$ Strip Plate is now fitted to the firing end of the model together with two $5\frac{1}{2}''$ Strips 3 and two similar Strips 4 and 4a. The centre of the long Strip Plate supports a $2\frac{1}{2}'' \times \frac{1}{2}''$ Double Angle Strip 5, that will be used later for supporting the gun.

This structure of Strips and Strip Plates is strengthened by means of two bracing members, each of which consists of a $5\frac{1}{2}''$ and $3\frac{1}{2}''$ Strip. The sides of the shooting space are each filled in by means of two $12\frac{1}{2}''$ Braced Girders and one $5\frac{1}{2}'' \times 2\frac{1}{2}''$ Strip Plate. Two $12\frac{1}{2}''$ Strips bolted together and overlapping six holes are held in place above the Braced Girders and secured to them by Flat Brackets and a $3\frac{1}{2}''$ Strip 6.

A $12\frac{1}{2}''$ Strip is now bolted across the bottom of the rear

flanges of the $5\frac{1}{2}'' \times 2\frac{1}{2}''$ Flanged Plates already mentioned and above this is fitted two $12\frac{1}{2}'' \times 2\frac{1}{2}''$ Strip Plates 7. A further similar Strip Plate is attached to the front flanges of the Flanged Plates together with two $12\frac{1}{2}''$ Strips 8 and 8a.

At the rear of the Angle Girder 2, three Obtuse Angle Brackets are fitted and these support two $5\frac{1}{2}'' \times 2\frac{1}{2}''$ Strip Plates 9. This compound Strip Plate, that forms a guard against Balls "fired" high, is suitably decorated with $2\frac{1}{2}''$ large and small radius Curved Strips as shown.

Two $1'' \times 1''$ Angle Brackets are now fitted to the inside of the Strip 8a, these being held in place by the Bolts 10. These Angle Brackets support an $11\frac{1}{2}''$ Rod on which are pivotally carried nine $2\frac{1}{2}''$ Strips, each of which is held in its

appointed position by two Spring Clips. The upper end of each Strip carries a $\frac{1}{2}'' \times \frac{1}{2}''$ Angle Bracket in the slotted hole of which a bolt is accommodated carrying a Washer. A small piece of card, on which a cat or other animal is drawn, is clamped in place between the Angle Bracket and Washer.

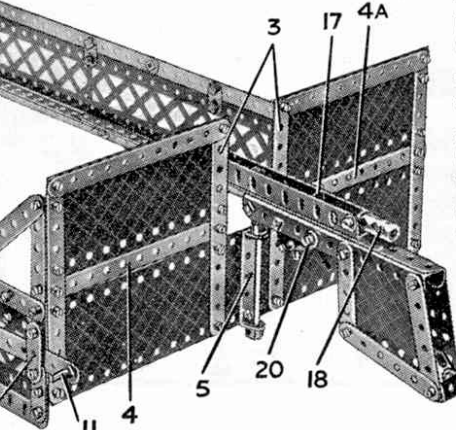

Fig. 3. A thrilling Shooting Game built with Outfit G.

When a shot is fired and one of the "dummies" is knocked backwards, it is brought back into line at the end of a "shoot" by means of the Threaded Pin 11. This Threaded Pin is locked in the end hole of a long Strip that is held in

position behind a $1\frac{1}{2}''$ Strip 12, as shown. The other end of the long Strip is pivotally attached by a bolt and Collars to a short Rod that is carried in the longitudinal bore of a Coupling 13. This Coupling is accommodated on the outer end of a long Rod formed from an $11\frac{1}{2}''$ and a $2''$ Rod. On this Rod two Cranks are carried, one of which is shown at 14. Each Crank carries a $\frac{1}{2}'' \times \frac{1}{2}''$ Angle Bracket at its upper end, and these two parts are joined together by means of two $5\frac{1}{2}''$ Strips 15.

The "trigger" of the pistol is represented by a Threaded Pin 19 that is screwed into one of the tapped holes of a Swivel Bearing carrying the Rod 21. The Threaded Pin is screwed in tight against the shank of a Pivot Bolt that carries a Collar and four Washers. The Collar is pivotally connected to the gun by two $\frac{3}{8}''$ Bolts 20.

The parts required to build the Shooting Game are as follows: 9 of No. 1; 16 of No. 2; 3 of No. 3; 6 of No. 4; 11 of No. 5; 1 of No. 6a; 8 of No. 8; 4 of No. 9; 9 of No. 10; 2 of No. 11; 17 of No. 12; 2 of No. 12a; 3 of No. 12c; 2 of No. 13; 1 of No. 15b; 1 of No. 16; 3 of No. 18a; 18 of No. 35; 156 of No. 37; 24 of No. 38; 1 of No. 43; 1 of No. 48; 1 of No. 48a; 2 of No. 52; 7 of No. 59; 2 of No. 62; 3 of No. 63; 1 of No. 77; 4 of No. 90; 3 of No. 90a; 4 of No. 99; 4 of No. 111c; 2 of No. 115; 1 of No. 116a; 1 of No. 147b; 1 of No. 165; 2 of No. 190; 6 of No. 195; 4 of No. 197

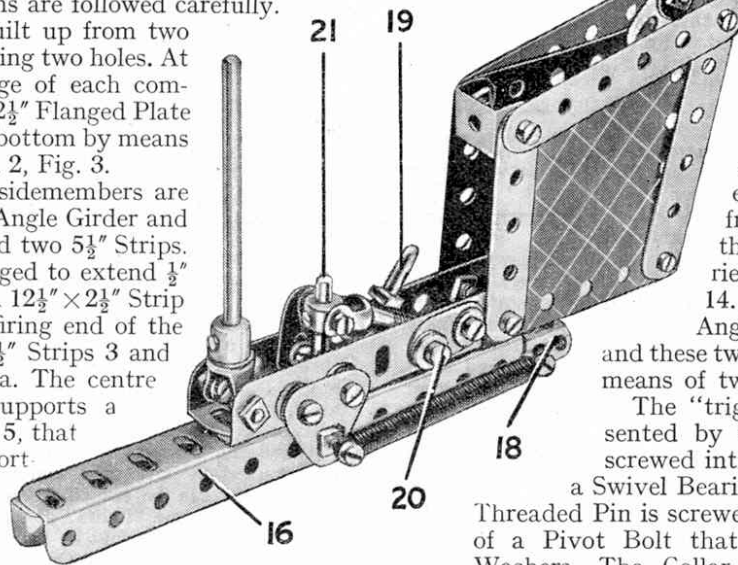

Fig. 4. The gun that is used for firing the steel balls in the Shooting Game. It is shown upside down to make the construction clear