

# PROJECT SECTION THE SAAB A37-VIGGEN.

An exclusive MM design by Ray Malmström

**B**UILDING an unusual type of model aeroplane is always an exciting business, and when the model flies as well as this one, then you really can be assured of flying thrills ahead. The new SAAB A.37. VIGGEN (Swedish for Thunderbolt) is without doubt one of the most deadly and advanced fighters in the world today, and is destined to go into squadron service with the Swedish Royal Air Force. The design is a delta-canard type and appears to fly *backwards* with its tail-plane *in front*. Contrary to what you may expect, this lay-out flies exceptionally well (two big advantages of tail-first or canard types are their stability and freedom from stalling). Construction too in our model, is simple and straightforward—so what are we waiting for!

These constructional notes will concentrate on the more important building points. Generally speaking if you follow the 'easi-build' sketches, work slowly and accurately, construction will not present any problems. Build two identical fuselage side frames and add the sheet top, bottom and side pieces as shown in the sketches. Check that the forward elevator and wing cut-outs are accurate. A set-square is useful, for checking the 'squareness' of the fuselage. Add elevator and wing dowel rods. Both elevator and wing are held in place with rubber bands. This allows for slight changes in the incidence angles—but this should not be necessary. Note the slight slope of the rear end of the fuselage. *This slope is important* so check that you have built it in correctly. Build tailblock from plan and sandpaper to shape. Make it a good push-fit into the fuselage. Get the 20 s.w.g. brass bush from your model shop. The propeller is a KeilKraft 5 in. diameter, plastic prop. also obtainable at your hobby or model shop. Carefully cut off the spinner portion with a small tenon or hack saw, holding the prop. hub in the end of a vice. Take care to mount it on the driving shaft with the smaller face of the prop. hub *towards the tailblock*.

Remember this model is a pusher! Sandpaper the fuselage frame with very fine sandpaper, cover with lightweight Modelspan tissue paper, water-shrink and give one thin coat of clear dope. Build the upper main fin over the plan, lightly sandpaper and cover with tissue, shrink and dope as for fuselage. Fin and wing frames should be pinned down (using small balsa blocks, under the edges to stop the undersurfaces from sticking to building board) at all stages of shrinking and dopping. This will avoid warps. Cement fin in position. Build elevator, referring to the 'easi-build' sketches. Make sure that you add the tissue strips over the centre section score-lines, and that you have the correct dihedral. Use

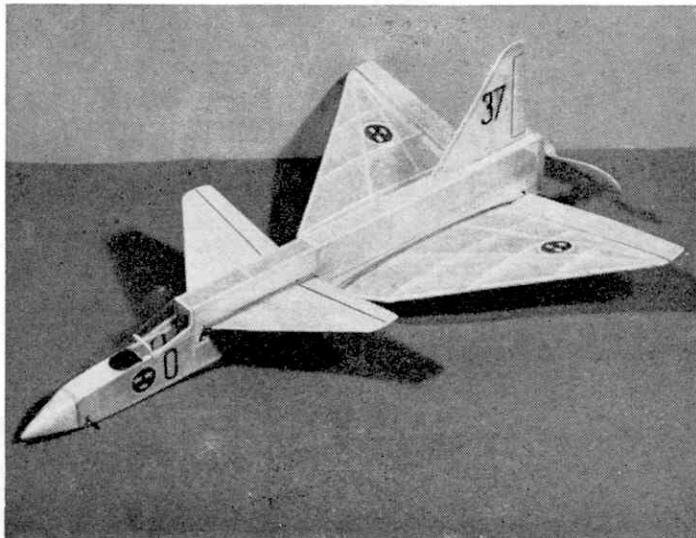

blocks of the correct height as indicated. Give elevator one coat of thin clear dope. Cut underfin from sheet, then dope and cement very firmly in place.

The delta (or triangular) shaped wing is built in three sections. Two wing panels and a centre section. Leave the  $\frac{1}{32}$  in. sheet covering over the wing centre section until the whole wing assembly has been completed. Build the port wing panel over the plan. You will need a reversed

tracing for the starboard panel. Before covering, cement the wing panels to the centre section. Note the end or root-rib on each panel is sloped slightly inwards. Use the template provided to obtain the correct angle of slope. See also that the tips are raised the right amount. See 'easi-build' sketches. Cover wing panels with lightweight tissue then shrink and dope as for fuselage and fin. Now add the  $\frac{1}{32}$  in. sheet centre-section covering. Cut out the sheet elevators

and fix to the wing trailing edges with thin aluminium hinges. These hinges are best glued in place with an impact adhesive like Evo-Stick or Bostik 1. Balsa cement is not satisfactory for bonding metal to balsa. Decorate fuselage, fin and wings as indicated on plan and sketches. Do not use colour dope on your Viggen—its weight will spoil the flying performance but coloured Modelspan tissue can be used if you prefer. Cut out canopy, fold carefully and cement in place. The wing and front elevator are slipped through their respective openings, but remember to first cement a strip of  $\frac{1}{8}$  in. square balsa along the front edge of the elevator centre section and a strip of  $\frac{1}{8}$  in. square balsa down the left-hand side of the end of the fuselage. These are flying adjustments and must not be omitted. Rubber bands hold the elevator and wing in position.

**Flying.** Make up and lubricate the 'testflight' rubber motor as per plan instructions (tubes of rubber lubricant 6d). By the way *never* rub oil on to your rubber motors, as it will seriously affect the rubber. Install the motor, and then balance your model carefully. The balancing is most important. Suspend your model from the balance (or C.G.) point as shown in the sketches. You will need a small amount of noseweight (folded cement tube or sheet lead) which is put in the noseweight recess. Adjust the noseweight until your Viggen hangs level

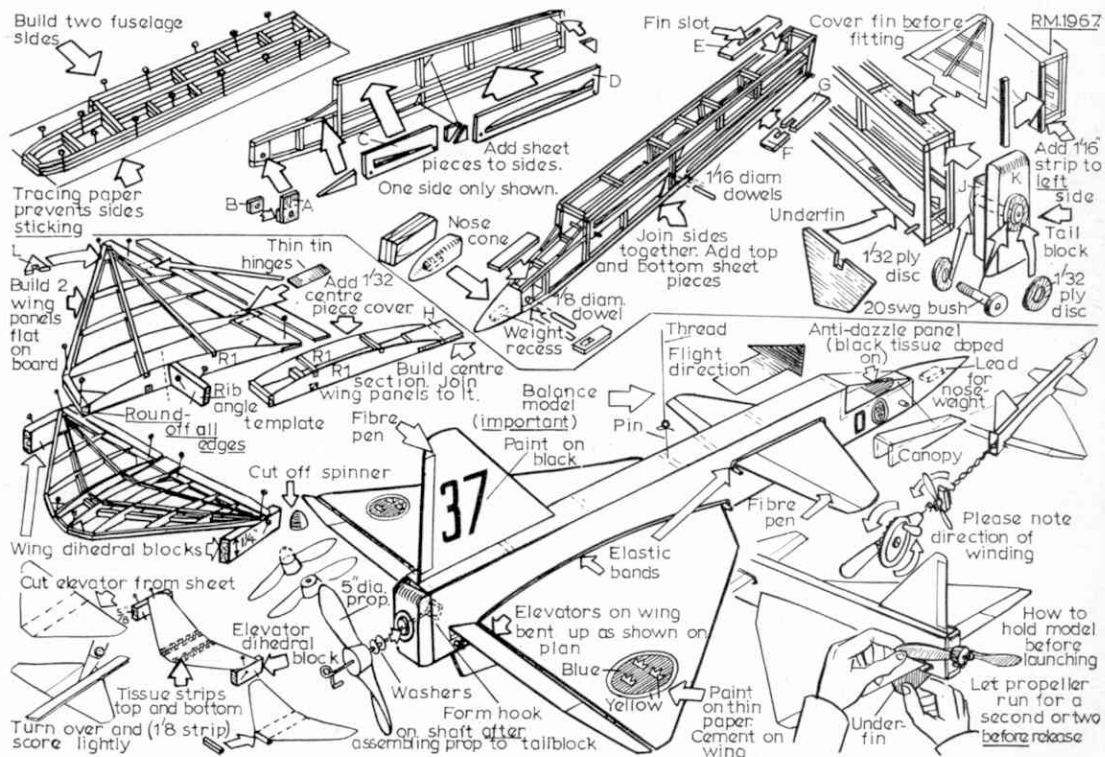

Ray Malmström, 1967.

Nose cone may be painted black

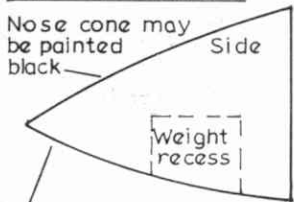

Nose cone from block

N.B. You can make the block for the nose cone by cementing three layers of 1/4 sht together.  
Fuselage 3/32 sq strip

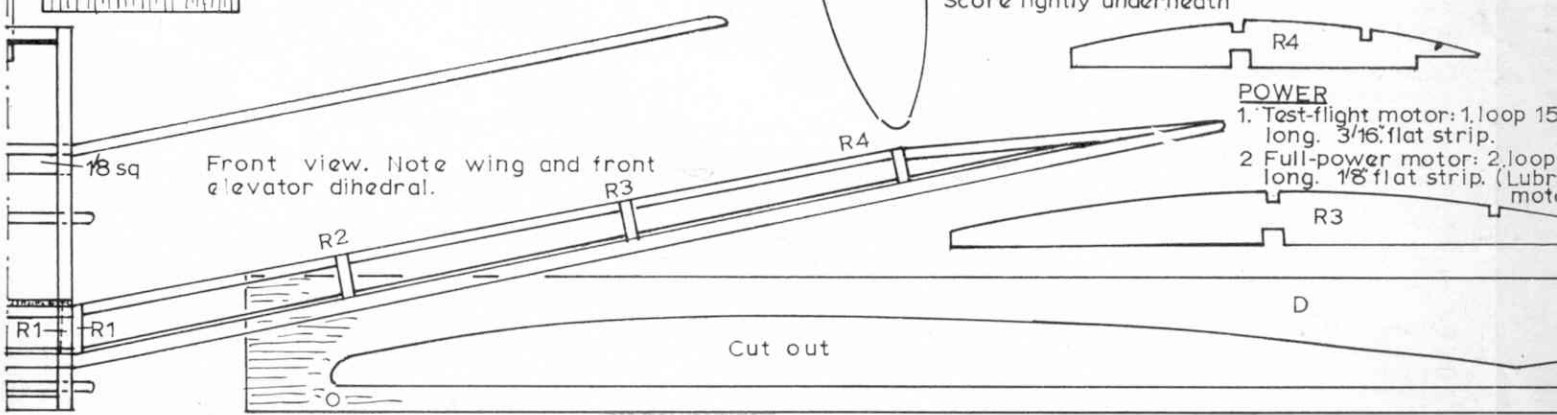
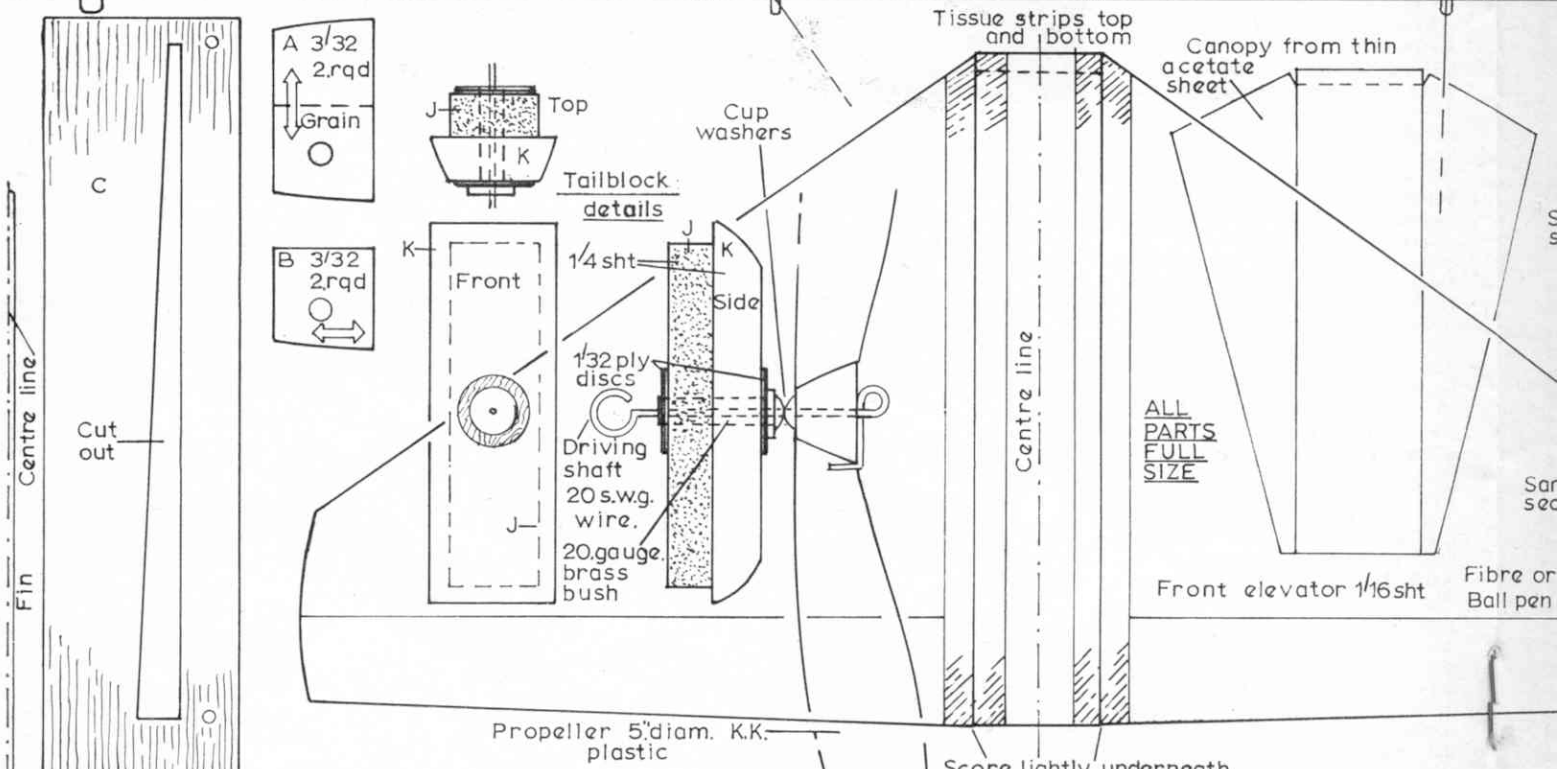
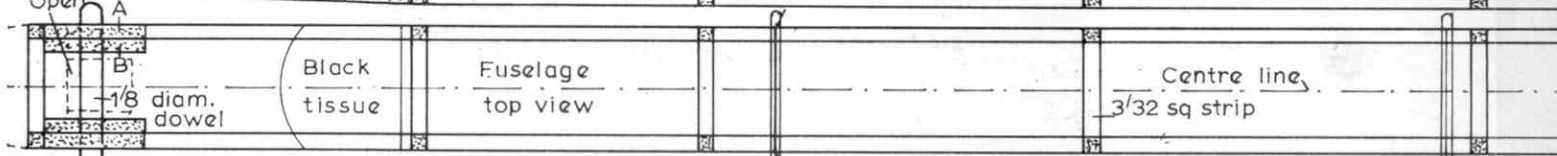
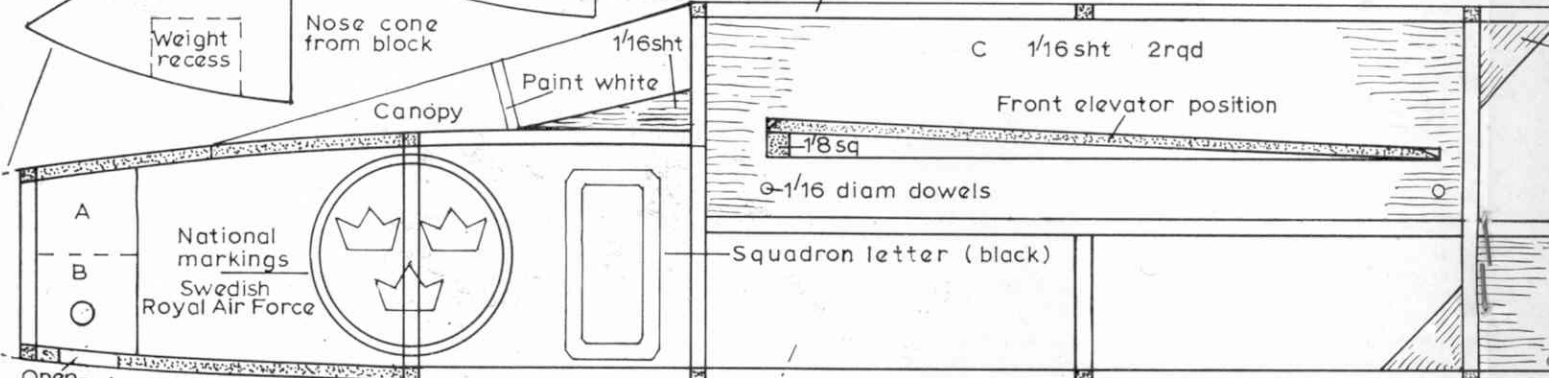

- POWER**
1. Test-flight motor: 1 loop 15 long. 3/16 flat strip.
  2. Full-power motor: 2 loop long. 1/8 flat strip. (Lubr motor)

# ECT SECTION

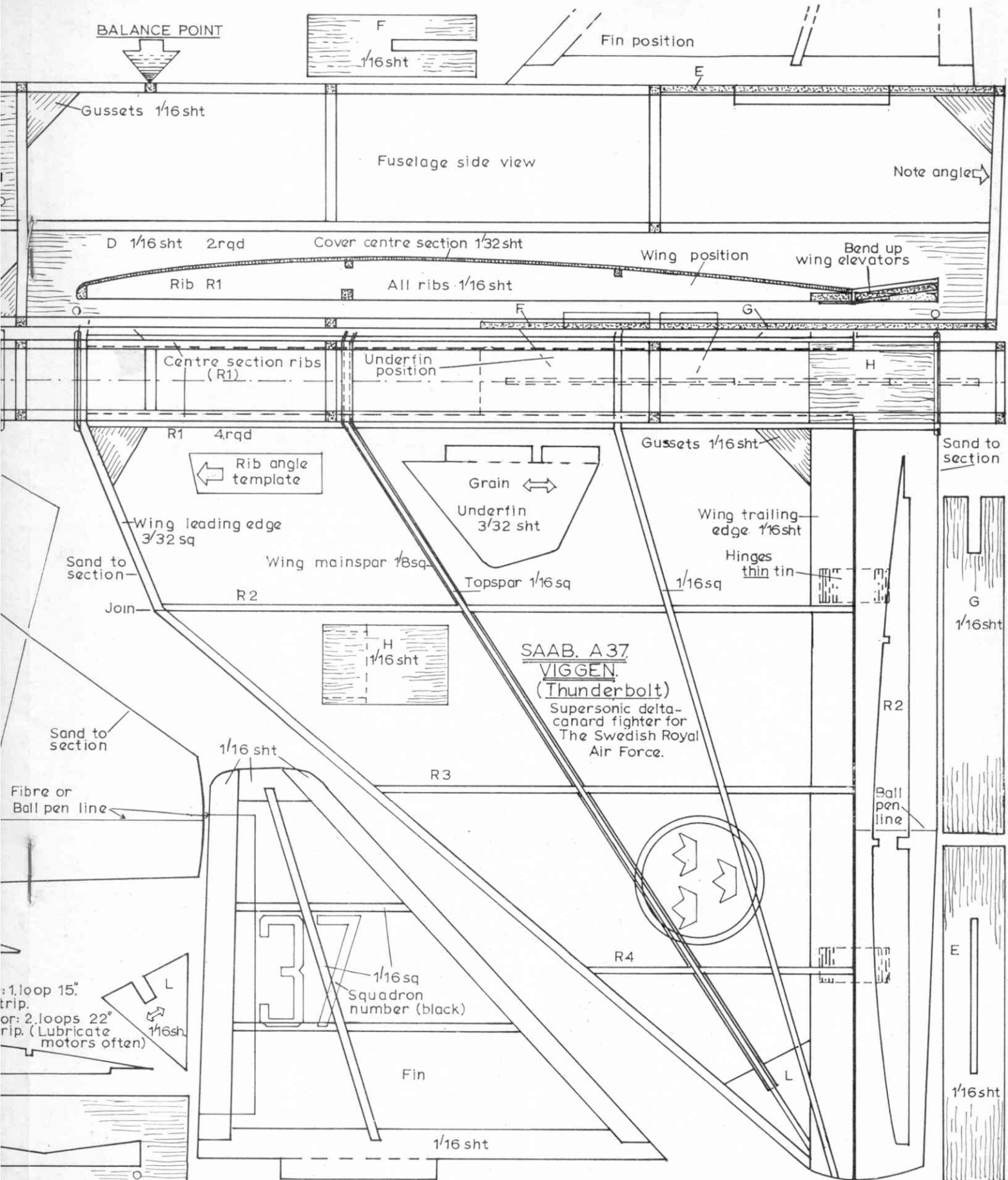

1. loop 15" trip.  
or: 2. loops 22" trip. (Lubricate motors often)



# PROJECT SECTION

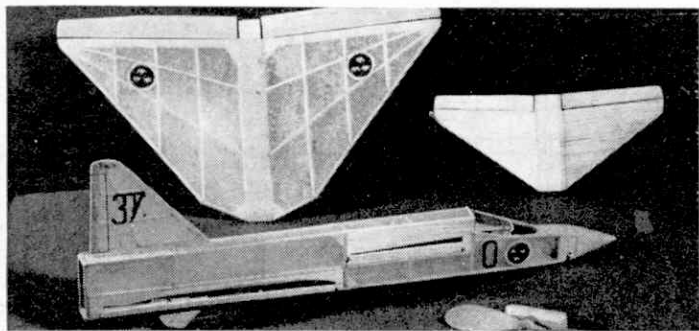

from both side and front views. Then carefully bend up the wing elevators about  $\frac{3}{8}$  in.

Choose a calm day and some long grass for your gliding and flying tests. Facing into the wind launch your Viggen with both wings level to the ground. Never throw the model, but launch with a 'follow-through'

movement of the arm. The model should glide down and land about 25 ft. in front of you. If it stalls (rears up and then dives in) bend the wing elevators down a little. If it dives, bend them up, a very small amount. If model turns sharply to left or right add a small paper trim-tab to the rear edge of the fin, and bend it in

the opposite direction to the turn. Get a fairly shallow and straight glide. Now wind the propeller about 200 turns. Note the way the propeller is wound. Hold the model and propeller as shown. Release the propeller a second or two before releasing model, again launching with a smooth follow-through arm movement. Your Viggen should climb gently for a short distance, level out, and then as the power dies glide into a smooth landing. Once you have your model flying satisfactorily you can increase the number of turns with each flight up to about 500. If the model stalls add a  $\frac{1}{16}$  in. square strip along the top edge of the tailblock. If it dives under power add a  $\frac{1}{16}$  in. square strip at the bottom of the tailblock. When your Viggen is making steady flights you can replace the 'test-flight motor' with the 'full power' motor. This will take, when run in, about 700 turns, and Viggen will really be away.

If you are still in a little doubt about building this unusual model perhaps this will convince you: our original Viggen (the one in the photo-

graphs) flew right off the drawing board and in 25 test flights never caused the designer's heart to miss a single beat! Who can ask for more than that?

## "Viggen" Material List

- 8 36 in. by  $\frac{3}{4}$  in. sq. balsa strips
- 1 36 in. by  $\frac{1}{4}$  in. sq. balsa strip
- 1 sheet 3 in. by 36 in. by  $\frac{1}{2}$  in. balsa
- 1 sheet 3 in. by 10 in. by  $\frac{1}{4}$  in. balsa
- 1 piece 8 in. by 1 in. by  $\frac{1}{2}$  in. sheet
- 1 small piece  $\frac{1}{2}$  in. sheet
- 1 sheet Modelspan lightweight tissue
- 1 small piece of black tissue
- 1 small piece  $\frac{1}{2}$  in. plywood
- 6 in. length 20 swg. piano-wire
- 1 brass bush 20 gauge
- 2 cup washers 30 gauge
- 1 KeilKraft (K.K.) 5 in. diameter plastic propeller
- 1  $\frac{1}{4}$  in. length  $\frac{1}{8}$  in. diameter dowel rod
- 6 in. length  $\frac{1}{8}$  in. diameter dowel rod
- 1 small piece thin acetate sheet
- 2 rubber bands (2 in. and 3 in. approx.)
- Small piece of thin tin or aluminium
- 1 tube balsa cement
- 1 tube Evo-Stik
- 1 small bottle clear dope
- 1 tube rubber lubricant
- 1 length 32 in. long  $\frac{1}{8}$  in. flat strip rubber
- 1 length 88 in. long  $\frac{1}{8}$  in. flat strip rubber
- Enamel or poster paint for decor

# A BALSA DRAGSTER

By Ron Warring

**S**IMPLE models of this type are ideal for 'sprint' racing over flat surfaces, such as a lino covered floor. Using a powerful rubber motor—four or six strands of  $\frac{3}{8}$  in. aero strip, for instance—the power run is short, but acceleration tremendous. Because of this the dragsters are best run tethered, so that they describe a circle around a central pylon. This has the advantage of keeping the model under control, the length of line can be adjusted to suit the space available, and the model can be timed over a specific number of laps so that the actual speed can be worked out. Another great advantage is that models of this type cost little to construct—and nothing at all to operate!

The plan shows all necessary parts actual size for making a typical balsa dragster. Basis is a simple chassis assembly incorporating a pylon, on top of which the propeller shaft bearing is fitted. The addition of a body is quite straightforward, although not essential to the working of the model. It merely adds to the appearance. You can try alternative body shapes to the simple design shown, but the main thing is to keep the construction light.

Start with the main chassis member, which is a 6  $\frac{1}{2}$  in. length of hard  $\frac{1}{2}$  in. by  $\frac{1}{4}$  in. balsa. The full size drawing at the bottom of the plan shows how this is notched for the axle beams and drilled for the front tether point.

The axle beams are cut from  $\frac{1}{4}$  in. by  $\frac{1}{8}$  in. hard balsa strip. Simply cement into the main member slots. The rear axle is further supported by two triangular braces cut from  $\frac{1}{8}$  in. sheet balsa and cemented in place. The shape of the pylon can be traced off the side view drawing on to

medium hard  $\frac{1}{4}$  in. sheet balsa with the grain running from top to bottom. Cut out and cement to the main chassis member to complete the basic chassis unit.

Now make the propeller shaft bearing from hard brass strip. Note that this is pinned in place to the top of the pylon, and also bound with thread. For additional security, add a generous coating of cement.

The front rubber motor hook is bent from 18 gauge piano wire to the shape shown and bound securely to the front of the main chassis member. Again apply cement generously over the binding.

Lightweight plastic wheels are used for the front wheels. To make the rear wheel 'slicks', start with a pair of 2 in. diameter balsa wheels and sand the outside of the tyre section down until it is flat and the diameter is reduced to 1  $\frac{1}{2}$  in. Alternatively you can cut these 'slicks' directly from  $\frac{1}{4}$  in. balsa sheet (or better still two laminations of  $\frac{1}{4}$  in. sheet). It is most important, though, that you get these rear wheels perfectly circular. If in difficulties on this point it would be best to use ready-made 1  $\frac{1}{2}$  in. diameter wheels, even if they are normal tyre section.

All four wheels are mounted in the same manner. First mount on a large pin and check that the hole in the hub is large enough to let the wheel spin very freely. Turn down the pointed end of the pin, locate on the axle beam and bind in position with a washer between the end of the beam and the inside of the wheel. Coat the bindings with cement.

A body of  $\frac{1}{16}$  in. sheet balsa can now be added. Cut the two sides first and attach with cement to the front of the main chassis member and to the  $\frac{1}{8}$  in. sheet braces at the

rear. Now add the top and the two small pieces of  $\frac{1}{16}$  in. sheet filling in between the sides and the pylon aft of the cockpit. Finally add the  $\frac{1}{16}$  in. sheet fill-in to the sides of the cockpit.

You can leave the cockpit open, or fit a canopy if you prefer. In the latter case use a standard model aircraft canopy about 2  $\frac{1}{2}$  in. long. This will have to be cut both to fit around the pylon and sit on the top and over the open cockpit. You can only get a good fit by 'cut and try'.

For the propeller you can use a 4  $\frac{1}{2}$  in. diameter plastic aircraft type prop (or a 5 in. diameter prop trimmed to 4  $\frac{1}{2}$  in.). You will, however, get more thrust and thus more speed by using the 'fan' type propeller shown with four blades. This is made by cutting a 1 in. diameter hub from  $\frac{1}{4}$  in. sheet balsa and slotting as shown. Use a saw—or better still, a  $\frac{1}{16}$  in. thick flat file—for cutting these slots. The blades are simply cut from  $\frac{1}{16}$  in. sheet and cemented into the hub slots to complete the propeller.

The propeller is mounted on a piano wire shaft fitted through the bearing, with a washer between the rear of the bearing and the propeller hub. Turn the end of the shaft back into the hub to lock the propeller on to the shaft.

Power can be anything from a single loop of  $\frac{1}{4}$  in. aero strip (or a 5 in. or 6 in. wide rubber band), up. Low power will give the longest motor run and thus the greatest distance.] Increasing the power will increase the acceleration and speed. Adjust the power, as necessary, to suit both the length of tether line on which you are operating the model, and also whether you want speed or distance (i.e. maximum number of

laps). It is also recommended that you use a simple winder to wind the rubber motor from the front end (after detaching from the front hook) rather than hand wind via the propeller itself.

Tethering is accomplished by attaching two bridle lines to the points shown on the plan, joining about 3 in. out from the centre of the model, where they attach to the main tether line. This line can be as long, or short, as you need to run on the space available. The free end of the tether line is attached to a simple pivot mounted on a short pole—e.g. a piece of dowel about 3 in. or 4 in. long—mounted in a base. The base can be weighted down to prevent the model from pulling the centre pole out of position. All it will probably need is a couple of books or objects like that laid on the base.

For 'speed' and 'distance' runs, select the line length from the following table, remembering that tether length should be measured from the pole to the centre of the model. All that you then need to do is to count laps for working out actual distance covered; or time the model running over a specific number of laps to work out average speed.

LINE LENGTH* (To Centre of Model)	LAPS PER $\frac{1}{4}$ MILE	MILES PER LAP
17' 6"	12	-0208
13' 1 $\frac{1}{2}$ "	16	-0156
8' 9"	24	-0104
6' 3 $\frac{1}{2}$ "	32	-0078
4' 4 $\frac{1}{2}$ "	48	-0052

\*Use light thread line

# PROJECT SECTION

