

DECK PANELS $5\frac{1}{2}'' \times 3'' \times \frac{1}{8}''$

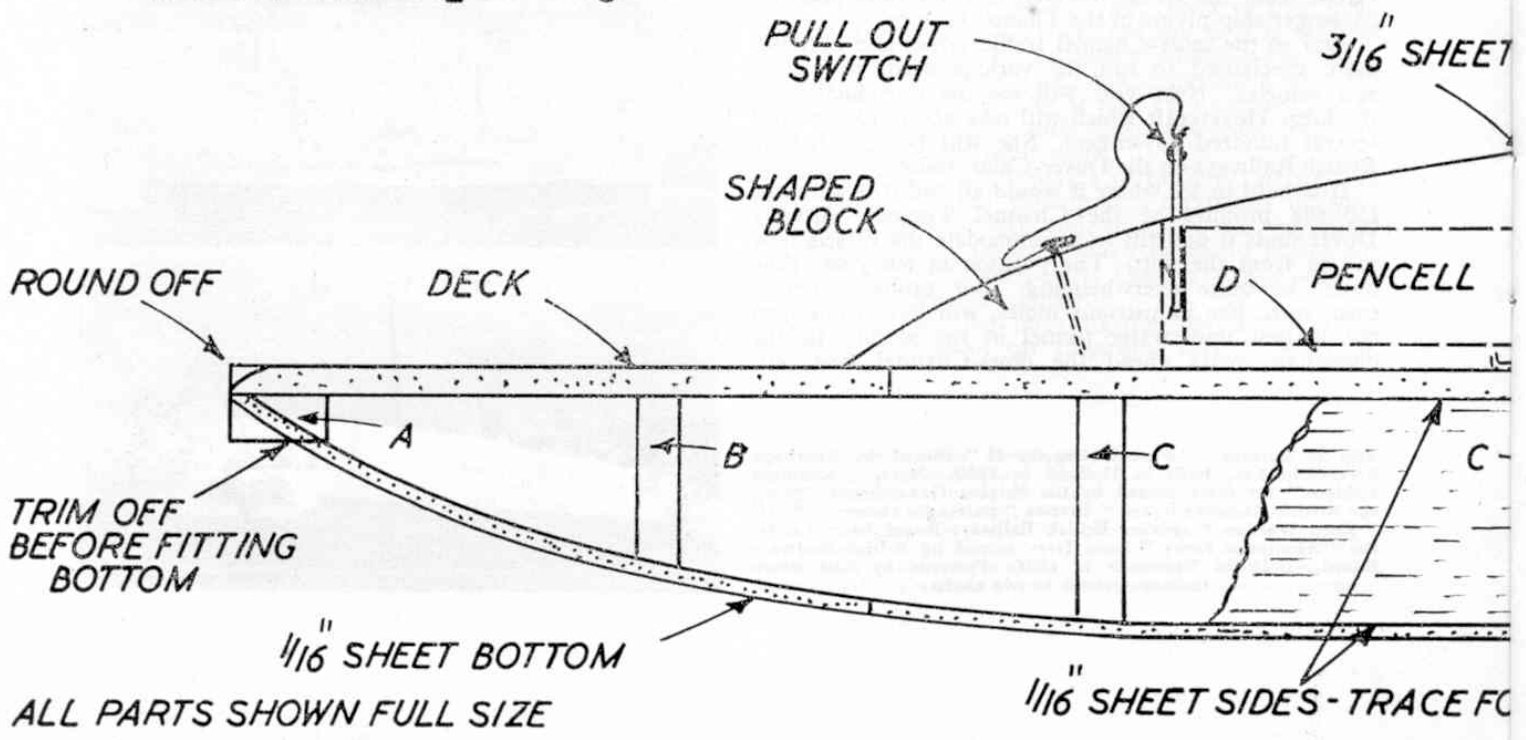

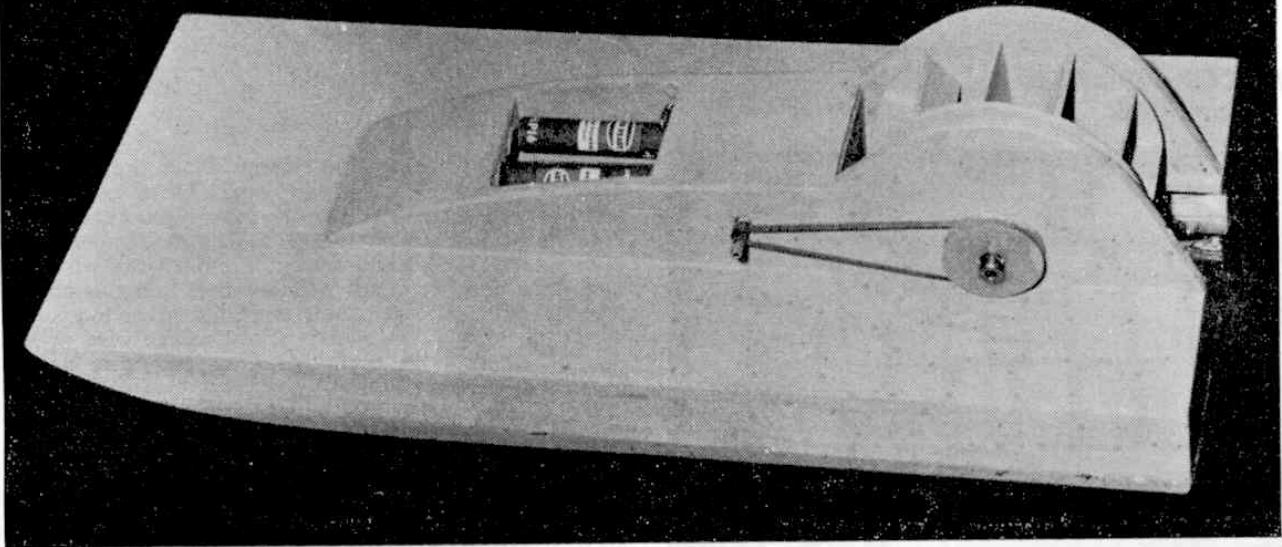

PADDLER ★ YOUR FULL SIZE FREE PLAN FOR A SIMPLE ELECTRIC POWERED BOAT

BY ADOPTING a single paddle wheel drive instead of a screw, this simple model can operate in shallow water and even run aground without "stalling" the motor (which is about the quickest way to ruin batteries!). We have given it modern lines and adopted a twin float layout for stability, so you need have no fears of it overturning in rough water. And, provided the two sponsons are not damaged, this model is un-sinkable.

Materials

Rather than work to a specific material list—which always involves "odd" sizes of balsa sheet, etc., which you cannot buy (you usually have to get a whole sheet)—here are the basic "stock" materials you require: one sheet of $\frac{1}{8}$ in. balsa 3 in. wide; one sheet of $\frac{1}{16}$ in. balsa 2 in. or 3 in. wide; one sheet of $\frac{1}{16}$ in. balsa 3 in. wide. This will give you enough material for all the parts you require, and leave some over for further models.

In addition you will require: a small electric motor (any size will really do, provided it will run properly on three volts); one 1 in. diameter plastic pulley wheel; a 3 in. length of 16 s.w.g. piano wire; some scrap brass sheet—about 3 in. x 2 in. will be enough

in 20 or 22 s.w.g.; a 1 in. length of 16 s.w.g. brass tubing; two cup washers; a 1 in. length of $\frac{1}{2}$ in. sq. balsa; and balsa block 2 in. x $\frac{3}{4}$ in. x $1\frac{1}{2}$ in.

Construction

Commence by cutting four $5\frac{1}{2}$ in. lengths from the 3 in. x $\frac{1}{8}$ in. balsa sheet. Cement these pieces edge to edge over a flat surface to make a panel 12 in. long by $5\frac{1}{2}$ in. wide. This forms the deck.

Make a tracing of the *side* from the full-size plan, transfer onto $\frac{1}{16}$ in. sheet balsa and cut out. Use this as a pattern to cut three more sides, so that you have four identical sides in all.

Now cut out the various bulkheads A, B and C from $\frac{1}{16}$ in. sheet balsa, noting the number required (see full-size parts drawing, page 100). You are now ready to start assembly.

With the deck still laid out on a flat surface, cement one side in place adjacent to one edge. Mark the bulkhead positions on the deck and cement in the bulkheads against that side. Then add the other side.

Repeat the operation on the other side of the deck, so that you have assembled the sides and bulkheads for both sponsons. Trim down the front bulkheads (A) when set and then proceed to cover the bottom of both sponsons with $1\frac{3}{4}$ in. lengths cut from 3 in. wide $\frac{1}{16}$ in. sheet balsa. Using strips in this manner instead of trying to cover the bottoms with one complete piece of sheet makes it easy to form the front curve and also gives a stronger assembly. Use plenty of cement and make sure that all joints are watertight.

Continued on next page.

PLAN INSTRUCTIONS

To construct Paddler remove the full size plan spread on page 80 and 101 by opening the binding staples and gently removing all the pages down to 80 and 101. Replace the centre of the magazine and close the staples. Full size component parts are drawn out on page 100, the extension of this page.

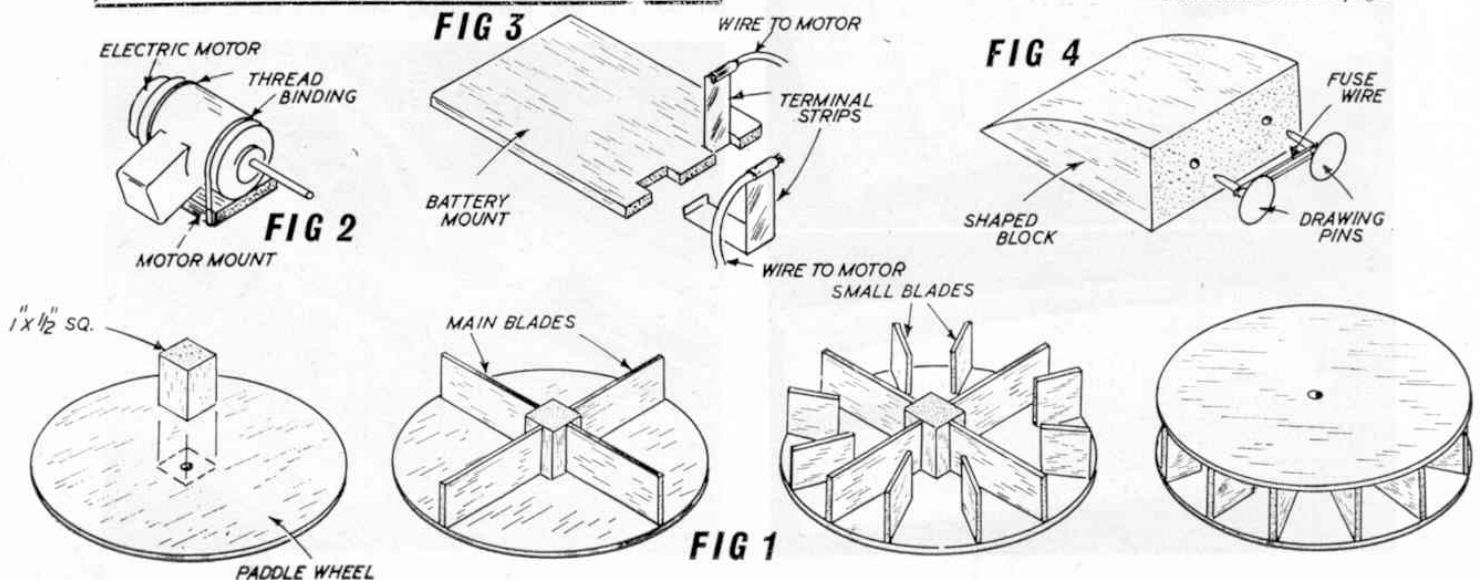

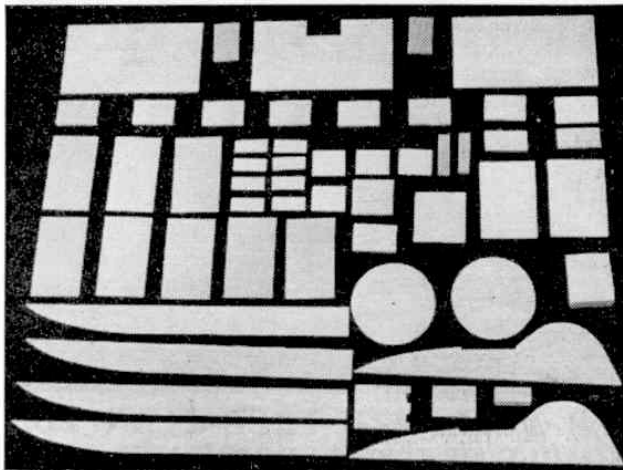

Now turn the hull the right way up. Trace the pattern for the deck cut-out given on the parts drawing and lay over the deck.

Cut the two main fairings from $\frac{1}{8}$ in. sheet balsa; and also bulkheads E and F from $\frac{1}{8}$ in. sheet balsa. Pierce a hole in each fairing where shown and into this hole glue a $\frac{1}{2}$ in. length of 16 s.w.g. brass tube to act as a bearing. It is best to use an epoxy resin glue for this job as this will give a very secure fixing. You can now cement the two fairings to the top of the hull, spaced apart by bulkheads E and F. The front end between the fairings is then filled in with a balsa block.

The next thing to make is the paddle wheel. Cut two plain paddle discs from $\frac{1}{8}$ in. sheet; four of the larger blades; and eight of the smaller blades—all from $\frac{1}{8}$ in. sheet again. Also cut *accurately* a 1 in. length of $\frac{1}{2}$ in. square balsa.

Pierce a centre hole *accurately* in each plain disc first, then proceed to cement on the hub piece, the main blades and then the small blades, as shown in Fig. 1. Finally cement on the other plain disc to complete the paddle wheel.

Pierce or drill a hole through the centre of the paddle, using a length of wire no bigger than 18 s.w.g.

diameter (20 s.w.g. will be better). Place the paddle in position and then put the 3 in. length of 16 s.w.g. brass wire through the bearings in the fairing pieces to mount the paddle wheel in place, also locating cup washers on each side of the paddle wheel. Provided the wire is a nice tight push fit in the paddle wheel hub this should provide sufficient "grip." If the fit is rather loose, you will have to lock the paddle wheel to the wire with a dab of epoxy resin each side—but take care not to glue the wire to the bearings.

Check that the paddle wheel spins freely and truly, then fit a 1 in. diameter plastic pulley to the protruding length of shaft on the left-hand side. Cut off surplus wire on the right-hand side.

Having decided on which electric motor to use, cut a motor mount from scrap $\frac{1}{8}$ in. sheet balsa to match the width of the motor and then *bind* the motor to this mount with thread—see Fig. 2. Secure by coating the binding generously with cement.

The motor is then dropped into position between bulkheads E and F, having first bored a hole or cut a slot in the left-hand fairing piece to let the motor shaft protrude. To secure, simply cement the motor mount to the deck.

The battery box comes next. Cut the battery mount from spare $\frac{1}{8}$ in. or $\frac{1}{4}$ in. sheet balsa to the shape shown. Cut the strips for the battery terminals from thin brass and bend to the shape shown. These fit into the notches in the end of the battery mount and are held in place when this mount is cemented in place to the deck. Note that the tops of the terminal strips are curled over to grip short lengths of wire to connect to the motor—Fig. 3.

The front connections for the two pencils are made as shown in Fig. 4. Simply push two drawing pins into the face of the shaped block in line with the ends of the two pencils and connect the two drawing pins electrically by binding them with fuse wire.

A very simple "switch" is shown on the plan. This is a small piece of fairly stiff plastic sheet (or even thin ply will do) which is tied to a length of thread. Make "off" the other end of the thread on a pin and push into the shaped block. This will ensure that the plastic "switch plate" is not lost. To switch "off" simply push the plastic between the end of one battery and its terminal (drawing pin). To switch "on," simply pull out the switch plate. Happy paddling!

Very easy to construct, Paddler only uses simple balsa components as laid out at the head of this page; they can all be cut with a modelling knife. Left: the semi-complete hull showing 3/16 in. sheet pontoon formers and sheet sides. Lower left: glass headed modelling pins hold the cross grain pontoon bottom sheeting until the cement sets. Below: we used a Ripmax 1 in. dia. plastic pulley wheel and elastic band drive.

