

# New Meccano Models

## A Motor Cycle and Sidecar and a Useful Balance

THE neat motor cycle and sidecar shown in Figs. 1 and 2 is driven by a *Magic* Clockwork Motor built into the position normally occupied by the engine of an actual machine.

The frame of the cycle is made by bolting two  $2\frac{1}{2}$ " Strips 1 on each side to the side-plates of the Motor. The Strips seen in Fig. 1 are fixed direct to the side-plate, but only temporarily, as at a later stage in the construction the bolts will have to be removed in order to fit the sidecar. The Strips shown in Fig. 2 are connected to  $\frac{1}{2}$ " Bolts, each of which is attached to the Motor side-plate by two nuts. The Strips 1 are connected at their upper ends by  $3\frac{1}{2}$ " Strips 2, which form part of the petrol tank.

Each side of the tank is completed by a further  $3\frac{1}{2}$ " Strip 3, and this is linked by a Fishplate at its forward end to Strip 2. The front of the tank is filled in by four  $1" \times 1"$  Angle Brackets, two of which are bolted to the Strips 2, while the remaining two are fixed to Strips 3. A Coupling 4 is connected to the latter pair of Angle Brackets by two bolts passed through the Brackets and screwed into tapped holes of the Coupling.

The rear wheel is supported on each side by a  $4\frac{1}{2}$ " Strip 5 and a  $2\frac{1}{2}$ " Strip 6. These Strips are attached to the main frame as shown in Fig. 2, and a  $1\frac{1}{2}$ " Rod is mounted in the end hole of Strip 6 and the centre hole of Strip 5. The Rod is

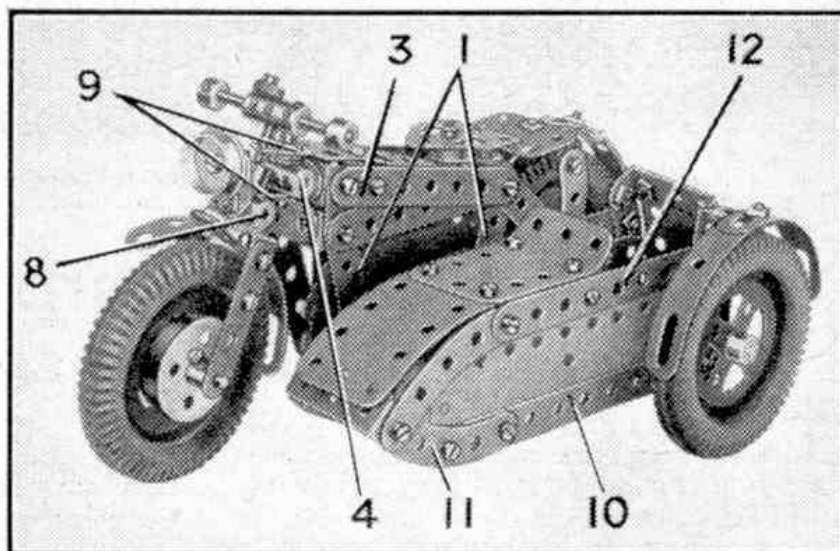

Fig. 1. A neat motor cycle and sidecar, which has a *Magic* Motor for its power unit.

fitted with a  $1\frac{1}{2}$ " Pulley 7, a 2" Pulley and Motor Tyre, and a 1" loose Pulley. The  $1\frac{1}{2}$ " Pulley is connected to the *Magic* Motor pulley by a Driving Band.

The driver's saddle is a Flat Trunnion that is attached by a  $\frac{3}{8}$ " Bolt, which carries six Washers, to a 1" Triangular Plate. The Triangular Plate is bolted to two  $1" \times \frac{1}{2}"$  Angle Brackets fixed between the rear ends of Strips 2. The rear mudguard consists of two Formed Slotted Strips bolted to a Double Bracket attached to the end holes of Strips 5. It is braced by a 2" Strip on each side. These Strips are passed over the rear axle, and are connected at their upper ends by a  $1\frac{1}{2}" \times \frac{1}{2}"$  Double Angle Strip that is bolted to the mudguard.

The front fork is made by joining together two  $1" \times 1"$  Angle Brackets by bolts passed through the Brackets into the tapped holes of a Coupling 8. The front wheel is free to turn on a  $1\frac{1}{2}"$  Rod passed through the end holes of 2"

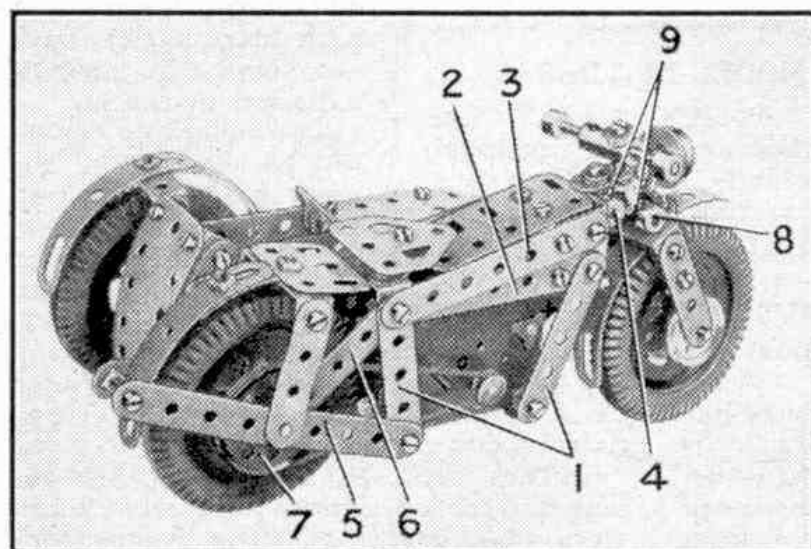

Fig. 2. Another view of the motor cycle and sidecar.

Strips bolted to the Angle Brackets. A 1" loose Pulley is placed on one side of the wheel, and a 1 1/8" Flanged Wheel is fixed on the Rod at the other side.

A 1 1/2" Rod is fixed in the centre hole of Coupling 8, and this Rod is free to turn in two Fishplates 9, placed one above and one below the Coupling 4 and fixed in place by bolts screwed into the Coupling. The front mudguard consists of a Formed Slotted Strip and a 1 1/2" Strip which are bolted to a 1" Triangular Plate held by the same bolts that fix the Angle Brackets to the Coupling 8. The headlamp is a 3/4" Flanged Wheel bolted to an Obtuse Angle Bracket that is fixed by a nut and bolt to the Coupling 8.

Each side of the sidecar is made from a 5 1/2" x 1 1/2" Flexible Plate braced along its lower edge by a 5 1/2" Strip 10, and extended by a 2 1/2" Curved Strip 11. The upper edge of the side is made from a 2 1/2" Curved Strip and a 4 1/2" Strip 12, and the rear edge is a further 2 1/2" Curved Strip. The sides are connected together by two 1 1/2" x 1/2" Double Angle Strips at the rear, and by one 1 1/2" x 1/2" Double Angle Strip at the front. The back is filled in by a 2 1/2" x 1 1/2" Flexible Plate bolted to one of the Double Angle Strips, and the nose is completed by two 2 1/2" x 1 1/2" Flexible Plates shaped as shown and attached to the sides by Angle Brackets.

The sidecar axle is a 1" Rod held in a Coupling that is fixed vertically to the side by a 1/2" Bolt passed through

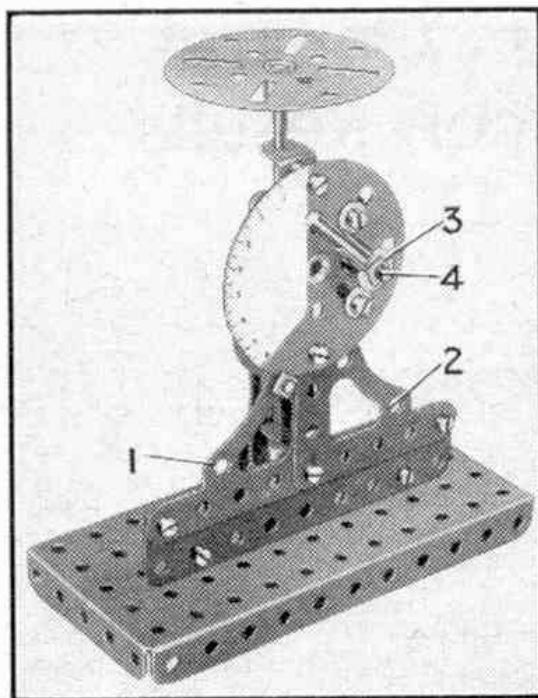

Fig. 3. A useful weighing balance for light articles.

the next-to-end hole of Strip 10.

The two bolts holding Strips 1 to the Motor are now removed, and two 1 1/8" Bolts are passed through the lower edge of one side of the sidecar and are fixed in position by nuts. The Bolts are then passed through Strips 1 and the Motor side-plate, and each is held in place by two nuts.

Our next model is a useful balance suitable for weighing light articles. Construction should be begun by bolting a 3 1/2" Angle Girder to a 5 1/2" x 2 1/2" Flanged Plate, and then attaching a 4 1/2" Flat Girder to the

Two Corner Gussets 1 and

Angle Girder. Two Corner Gussets 1 and 2 are bolted as shown to the Flat Girder and these support a Face Plate. The dial pointer consists of a 1" Rod held in a Rod and Strip Connector 3. The Rod and Strip Connector is fixed to the shank 4 of a Rod Socket, which is mounted on the end of a 1 1/2" Rod journalled in a hole in the Face Plate and in a Double Arm Crank bolted to it.

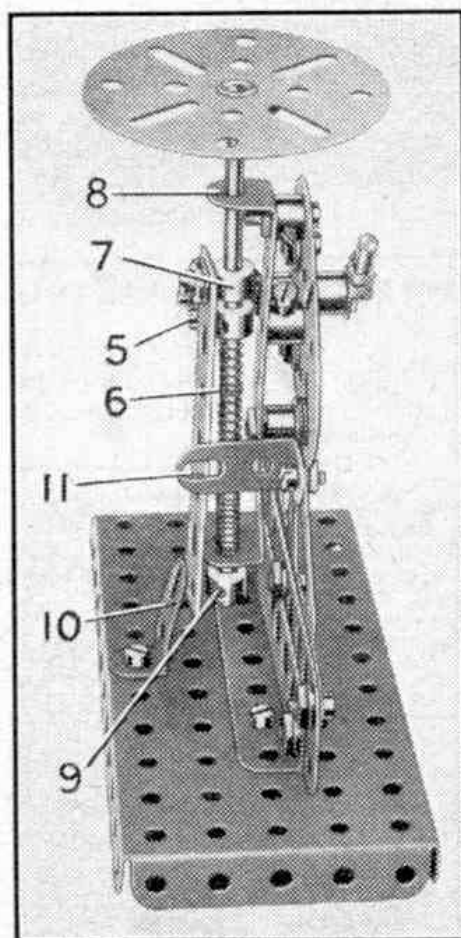

Fig. 4. A side view of the balance showing the constructional details of the mechanism.

The 1 1/2" Rod carries also a Washer and a 1/2" Pinion 5. The Pinion engages the teeth of a 3 1/2" Rack Strip 6, which is bolted to a Collar 7, fixed to a 5" Rod. It will be found necessary to space the Rack Strip from the Collar by means of a Washer. The 5" Rod is free to move in the arms of a 3 1/2" x 1/2" Double Angle Strip 8, which is bolted to the Face Plate by means of 1/2" Bolts, Collars on the Bolts being used to space the Double Angle

(Continued on page 334)