

## New Meccano Model

# 6-inch Howitzer Equipped with Limber and Tractor

**D**URING the Great War howitzers were used to a very large extent in consequence of the change from open warfare, with which activities commenced, to the trench warfare that developed as the war progressed. Howitzers of 6" and 8" calibre as a general rule are easily capable of transport on their own carriages along ordinary roads or across fairly level country. For siege operations large calibres, entailing special means of transport, are necessary.

The particular howitzer forming the prototype of the Meccano model has a calibre of six inches and is capable of firing a projectile weighing 100 lbs. It is mounted on a field carriage of very massive construction, which runs on a pair of wheels of the ordinary heavy gun-carriage type. The total weight of the equipment, excluding the ammunition limber, is 3 tons 10 cwt., and it may be drawn either by horses or by mechanical traction. Some idea of the great power of this weapon will be gained when it is learned that the projectile leaves the muzzle of the gun at a velocity of 1,250 feet per second, and when fired at an elevation of 45 degrees the range of the gun is about 10,000 yards.

Construction of the model should be begun with the building of the Howitzer. The trailing girders and gun pivot support (Fig. 7) are built up from two 5½" Angle Girders connected by ½" Reversed Angle Brackets 11 to two 3½" Angle Girders. The 5½" Girders are connected together by the Strips 7 and 7a and the 1" x 1" Angle Brackets 8. The 3½" Angle Girders carry 3" Strips 9 and 1½" Angle Girders 10, secured in the positions indicated in the illustration, to form extended bearings for the wheel axles. The gun proper is mounted pivotally in the 1" Triangular Plates 30 (see Figs. 1 and 7) that are rigidly secured to

the 3½" Angle Girders by 2½" Angle Girders.

The brakes acting on the road wheels are built up as follows. Each brake shoe consists of two ½" x ½" Angle Brackets 14, which are secured to a Crank that is attached pivotally to the frame by a ¾" Bolt. Each brake may be applied or withdrawn from the wheel by means of a 3½" Screwed Rod 13, which works in the transverse hole of a Threaded Boss attached pivotally to the Crank as shown, and is journalled in a Handrail Support 12 secured to the frame by a Double Bracket.

The recoil spade, consisting of a Flat Trunnion, is secured by a Collar to a 1½" Rod. This Rod carries the handle 35 and is journalled in two ½" x ½" Angle Brackets bolted to the Strip 7, the securing bolts passing through the rear end of the trailing girder. To counterbalance the weight of the barrel, ten 2½" Strips are secured by ¾" Bolts to each limb of the trailing girder.

The gun muzzle, which together with the recoil chamber is shown sectionally in Fig. 6, is built up from two 7½" Angle Girders 15 and 15a secured at their inner ends to a Coupling 16 by means of three set-screws and a ¾" Bolt 17. These set-screws and ¾" Bolt also retain in place inside the Coupling an

8" Rod, which carries two Compression Springs interlocked one with the other, so as to form a short, powerful spring. The end of one of the Springs is formed into a loop which serves to secure the Spring by means of a set-screw to the Collar 18.

The firing handle 19 (a 1½" Rod) is secured rigidly by a Coupling and ¾" Bolt to a 2" Strip that is attached pivotally to the Angle Bracket 20. The ¾" Bolt slides in the elongated hole of another

Angle Bracket 21, which is secured to the underside of the barrel and forms an efficient "stop" for the firing mechanism. Another

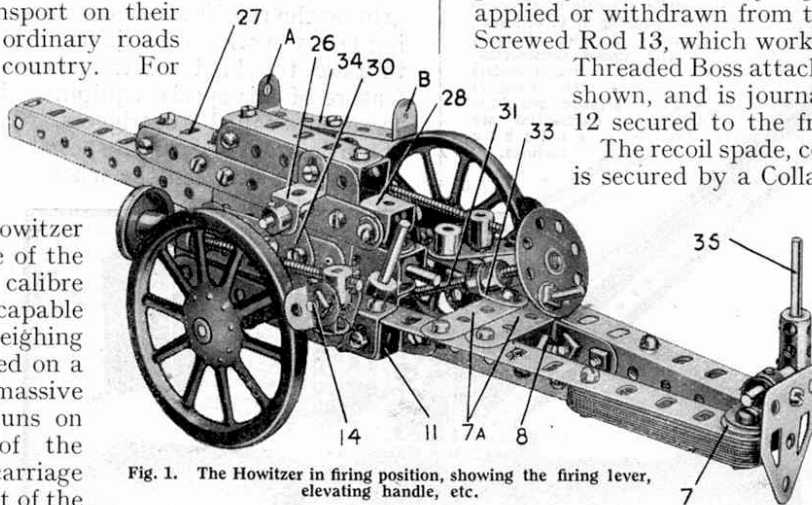

Fig. 1. The Howitzer in firing position, showing the firing lever, elevating handle, etc.

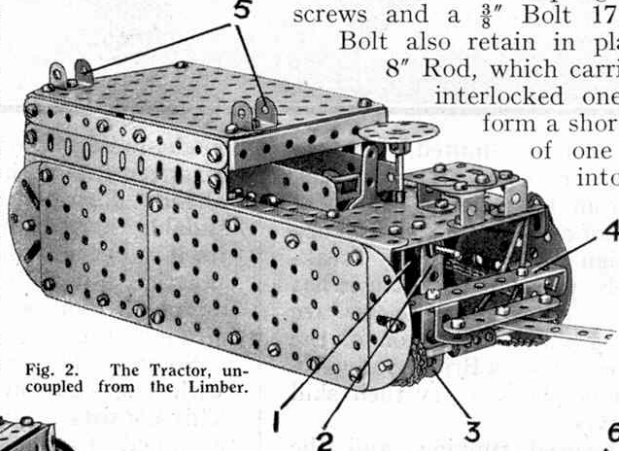

Fig. 2. The Tractor, uncoupled from the Limber.

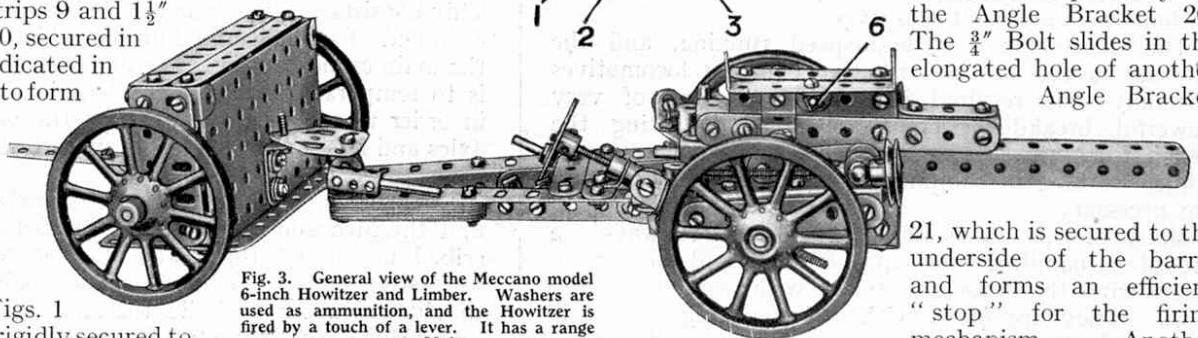

Fig. 3. General view of the Meccano model 6-inch Howitzer and Limber. Washers are used as ammunition, and the Howitzer is fired by a touch of a lever. It has a range up to 30 ft.

Coupling, secured to the 2" Strip by the Bolt 36, carries a  $\frac{3}{4}$ " Bolt 22, the end of which engages with the Washer (representing the shell) to be fired from the gun. Hence to discharge the gun, it is only necessary to apply a very slight lifting movement to the handle 19. The shot is pushed into position by a  $7\frac{1}{2}$ " Strip, which, when not in use, is carried in the Double Brackets 5 (Fig. 2) on the tractor. The complete gun barrel slides between the  $2\frac{1}{2}$ " Angle Girder 23 and the Angle Bracket 24, each of these parts being bolted to its respective side in the recoil chamber. The latter is constructed from two  $2\frac{1}{2}$ " x  $2\frac{1}{2}$ " Flat Plates joined together at top and bottom by  $2\frac{1}{2}$ " Angle Girders. Two  $\frac{1}{2}$ " Reversed Angle Brackets 26 (Fig. 1) and two  $4\frac{1}{2}$ " Strips 25 (Fig. 6) are bolted to the outside of the recoil chamber, and the  $1\frac{1}{2}$ " Angle Girder 27 and Double Bracket 28 are secured to the Strips 25 as shown in Fig. 6 to form a cover for the recoil spring, which is secured to the  $\frac{3}{8}$ " Bolts 17 and 29.

The recoil chamber with barrel in position is pivoted to the under-carriage by passing a  $2\frac{1}{2}$ " Rod through the 1" Triangular Plates 30 (Fig. 7), and through the  $\frac{1}{2}$ " Reversed Angle Brackets 26 (Fig. 1) and the side plates of the recoil chamber, the whole being held in place by Collars.

The elevating apparatus consists chiefly of a  $3\frac{1}{2}$ " Threaded Rod 31 (Fig. 1), which carries at one end a Bush Wheel and is journalled at the other end in a Threaded Boss 32 (Fig. 6) that is attached pivotally to the lower corner of the recoil chamber. The Threaded Rod is prevented from moving laterally by two Collars clamped to the Rod, one on each side of an Angle Bracket 33 that is secured in the position indicated.

An efficient sighting apparatus is attached to the gun. The  $2\frac{1}{2}$ " x  $\frac{1}{2}$ " Double Angle Strip 34 (Fig. 1) is bolted to an Angle Bracket 6 (Fig. 3), and the latter is attached by lock-nuts (see Standard Mechanism No. 262) to the recoil chamber, so as to allow a fairly stiff

swivelling movement. A very fine wire, about 36 S.W.G. is secured perpendicularly across the hole A and a piece of paper over the hole B, the paper having a pin hole punched in its centre. In view of the fact that the centre line of the sighting arm is to one side of the centre line of the barrel, it is necessary to move the arm inward or outward when altering the range.

At extreme range, which is approximately thirty feet, the sighting arm should point inward at an angle of half a degree to its own centre line.

For every decrease of 6 ft. in the range the arm should be moved inward half a degree, so that at 6 ft. range it will be at an angle of  $2\frac{1}{2}$  degrees.

This completes the Howitzer and the tractor may now receive attention. Each side of the tractor consists of two

$5\frac{1}{2}$ " x  $2\frac{1}{2}$ " Flat Plates over-lapped five holes, and two Face Plates, bolted one at each end. Four  $3\frac{1}{2}$ " x  $2\frac{1}{2}$ " Flanged Plates and one  $3\frac{1}{2}$ " x  $\frac{1}{2}$ " Double Angle Strip 4 (Fig. 2) are used to connect the two sides together, two of the Plates being used for the top and two for the bottom. The  $3\frac{1}{2}$ " x  $\frac{1}{2}$ " Double Angle Strip 4 is secured between the rear pair of Face Plates and carries two  $\frac{1}{2}$ " Reversed Angle Brackets. These are for use when coupling

the gun limber to the tractor. The upper edge of each side carries a  $9\frac{1}{2}$ " Angle Girder 37 (Fig. 4) to which is bolted a  $5\frac{1}{2}$ " Angle Girder 38. Two further  $5\frac{1}{2}$ " Angle Girders 39 are bolted across the two lower  $3\frac{1}{2}$ " x  $2\frac{1}{2}$ " Flanged Plates and form a bed for the Electric Motor as shown.

The next stage is the assembling of the mechanism, which is carried out as follows. A  $\frac{1}{2}$ " Pinion on the Motor armature shaft engages with a 57-teeth Gear that is secured to a  $2\frac{1}{2}$ " Rod carrying a  $\frac{3}{4}$ " Pinion 52. This Pinion meshes with a 50-teeth Gear on the Rod 40 and this Rod carries also a  $\frac{3}{4}$ " Pinion that engages with a further 50-teeth Gear on the Rod 41 carrying a  $\frac{3}{4}$ " Sprocket Wheel that is connected by Sprocket Chain to a 1" Sprocket Wheel 42 on a slidable layshaft. The latter is journalled in two  $3\frac{1}{2}$ " Strips 43 that are bolted to the next-to-bottom row of holes in the Motor side plates as can be seen in Fig. 4.

The layshaft carries, in addition to the 1" Sprocket 42, two  $\frac{1}{2}$ " Pinions 45 and two Collars 44. The Pinions must be so spaced on the Rod as to engage the 57-teeth Gears either simultaneously or separately. The Gears are secured on

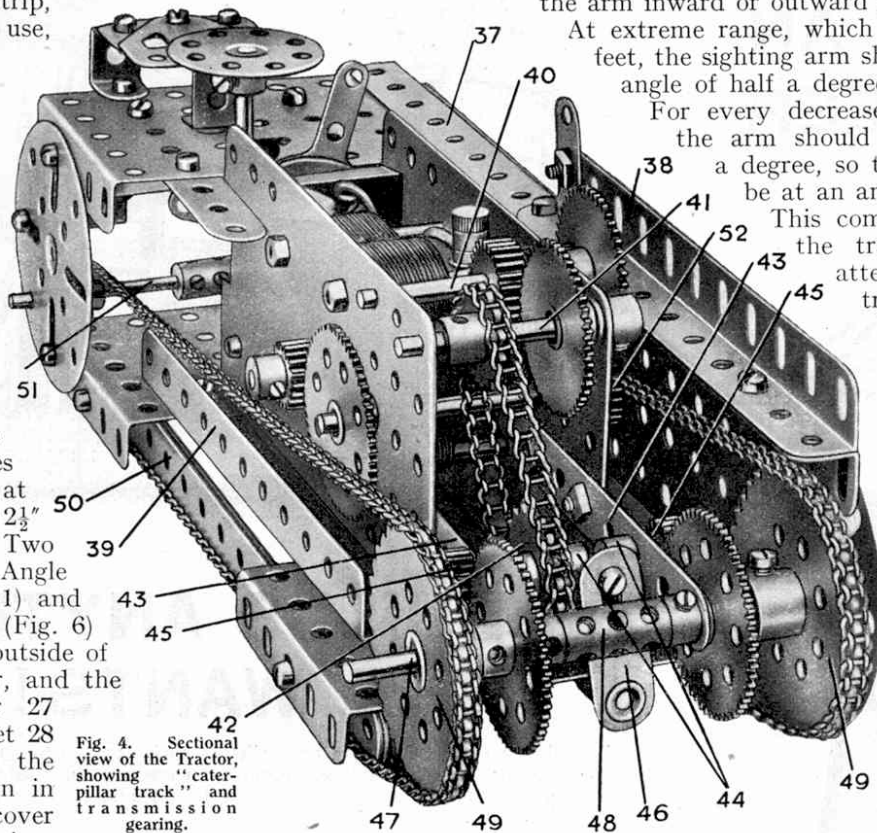

Fig. 4. Sectional view of the Tractor, showing "caterpillar track" and transmission gearing.

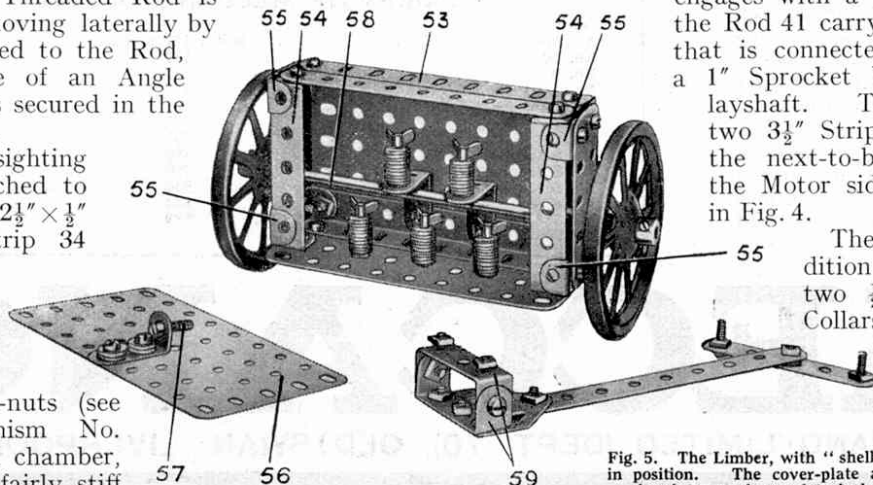

Fig. 5. The Limber, with "shells" in position. The cover-plate and drawbar are shown detached.

each side of the split rod 47, each half of which is journalled in one of the Face Plates on the side of the model and in one of the Strips 43. The inner ends of the two halves of the rod 47 are carried in a Coupling 48. Each carries also a 2" Sprocket Wheel, round which is passed a length of Sprocket Chain to form the "caterpillar" track. Each of the two chains passes round a  $\frac{3}{4}$ " Sprocket Wheel that is loose on the Rod 51, and also along the lower edges of two  $7\frac{1}{2}$ " Strips 50 that are bolted face to face. 28

The Strips 50 hold the tracks in contact with the ground. They are secured to the sides of the model by means of  $\frac{3}{4}$ " Bolts, and are spaced from the sides by Collars.

The two Collars 44 on the lay-shaft are spaced apart so as to allow a set-screw, carried in the elongated hole of the Crank 46, to move easily in the intervening space. The Crank 46 is nipped on an 8" Rod that is journalled in Angle Brackets bolted to the underside of the  $3\frac{1}{2}$ " x  $2\frac{1}{2}$ " Flanged Plates joining the sides of the tractor, and the opposite end of the Rod carries a second Crank 3 (Fig. 2) to which is secured a 2" Strip 2 carrying a Threaded Pin in its upper end hole. The portion of the shank of the Threaded Pin that protrudes beyond the securing nut may be engaged when desired, with the hole in a  $\frac{1}{2}$ " x  $\frac{1}{2}$ " Angle Bracket 1, which is secured to the top casing of the tractor by a bolt through its elongated hole. When the Threaded Pin rests in the hole of the Angle Bracket both 57-teeth Gears are in engagement with the Pinions 45 (Fig. 4) but on moving the lever to the right the right-hand Pinion is thrown out of mesh while the left-hand Pinion remains in mesh, thus causing the tractor to make a right-hand turn. A left-hand turn is carried out by moving the lever 2 over to the left, thus disengaging the left-hand Pinion and bringing the right-hand Pinion into mesh with its appropriate 57-teeth Gear.

The engine cover consists chiefly of two  $3\frac{1}{2}$ " x  $2\frac{1}{2}$ " Flanged Plates connected together along their edges by means of  $5\frac{1}{2}$ " Strips and across the top by a  $5\frac{1}{2}$ " x  $3\frac{1}{2}$ " Flat Plate. The ends of the cover are fitted with  $3\frac{1}{2}$ " x  $\frac{1}{2}$ " Double Angle Strips; the front Double Angle Strip carries also a  $3\frac{1}{2}$ " Flat Girder. Two Double Brackets 5 (Fig. 2) are bolted to the  $5\frac{1}{2}$ " x  $3\frac{1}{2}$ " Flat Plate and the complete engine housing is secured by means of four Flat Brackets, to the Angle Girders 38 (Fig. 4).

The tractor is completed by the addition of a dummy steering wheel and driver's seat. The steering wheel consists of a Bush Wheel secured to a  $5\frac{1}{2}$ " Rod that is journalled in the rear end pair of  $3\frac{1}{2}$ " x  $2\frac{1}{2}$ " Flanged Plates (Fig. 4). The driver's seat comprises two Flat

Trunnions bolted together to form a square, and secured to the rear of the tractor by means of three Double Brackets, the positions of which are shown clearly in Fig. 4.

The bottom of the Limber (Fig. 5) consists of a  $4\frac{1}{2}$ " x  $2\frac{1}{2}$ " Flat Plate, to which is bolted, by means of a  $4\frac{1}{2}$ " Angle Girder, a second similar Plate to form the back. A second  $4\frac{1}{2}$ " Angle Girder 53, bolted to the top edge of the latter plate, is connected by two Flat Brackets to a  $4\frac{1}{2}$ " Strip that, in turn, is secured to two  $2\frac{1}{2}$ " x  $\frac{1}{2}$ " Double Angle Strips 54, the other ends of which are secured to the bottom of the limber. Each side is enclosed by a  $2\frac{1}{2}$ " Flat Girder, which is secured by means of four  $\frac{1}{2}$ " x  $\frac{1}{2}$ "

Angle Brackets to the top and bottom of the limber.

The Flat Girders carry also four  $\frac{1}{2}$ " x  $\frac{1}{2}$ " Angle Brackets 55, these being spaced from the Double Angle Strips 54 by Washers so as to allow

a  $4\frac{1}{2}$ " x  $2\frac{1}{2}$ " Flat Plate 56 (shown separately) to slide in the intervening space.

The road wheels are free to turn on an 8" Rod 58. The Washers to be used in the gun are carried on  $\frac{3}{4}$ " Bolts secured inside the limber.

The draw-bar (see Fig. 5) consists of a  $5\frac{1}{2}$ " Strip attached by a Flat Trunnion to two  $1\frac{1}{2}$ " x  $\frac{1}{2}$ " Double Angle Strips 59, one of which is secured to the base of the limber by the Bolts shown.

The gun, limber and tractor may now be assembled into travelling formation. The gun is coupled to the limber by raising the recoil spade 35 (Fig. 7) and passing the end hole of the Flat Trunnion over the Bolt 57 on the limber. The tractor is coupled to the limber by passing the two  $\frac{3}{8}$ " Bolts in the pivoted Strip of the draw-bar, through the  $\frac{1}{2}$ " Reversed Angle Brackets bolted to the Double Angle Strip 4 of the tractor.

The parts required to build the model are:—

- HOWITZER; 2 of No. 2a; 2 of No. 4; 21 of No. 5; 2 of No. 6; 1 of No. 6a; 2 of No. 8b; 2 of No. 9; 2 of No. 9b; 6 of No. 9d; 4 of No. 9f; 3 of No. 11; 15 of No. 12; 2 of No. 12a; 1 of No. 13a; 1 of No. 16a; 2 of No. 17; 3 of No. 18a; 2 of No. 19a; 2 of No. 22; 1 of No. 24; 62 of No. 37; 1 of No. 37a; 8 of No. 38; 1 of No. 43; 1 of No. 48a; 15 of No. 59; 2 of No. 62; 4 of No. 63; 3 of No. 64; 2 of No. 72; 2 of No. 77; 2 of No. 80a; 1 of No. 80b; 4 of No. 111; 2 of No. 111a; 4 of No. 111c; 1 of No. 115; 4 of No. 125; 1 of No. 126a; 2 of No. 136. LIMBER; 1 of No. 2; 1 of No. 2a; 1 of No. 5; 2 of No. 9a; 2 of No. 10; 10 of No. 12; 2 of No. 12a; 1 of No. 12b; 1 of No. 14; 2 of No. 19a; 5 of No. 35; 34 of No. 37; 9 of No. 37a; 4 of No. 38; 2 of No. 48; 2 of No. 48a; 3 of No. 53a; 2 of No. 59; 2 of No. 103f; 5 of No. 111; 1 of No. 111a; 1 of No. 126a. TRACTOR; 5 of No. 1b; 2 of No. 2; 4 of No. 3; 1 of No. 6; 2 of No. 8a; 4 of No. 9; 4 of No. 10; 5 of No. 11; 1 of No. 13a; 1 of No. 16; 2 of No. 16a; 6 of No. 17; 1 of No. 24; 2 of No. 25; 2 of No. 26; 2 of No. 27; 3 of No. 27a; 2 of No. 35; 69 of No. 37; 8 of No. 38; 4 of No. 48b; 1 of No. 52a; 5 of No. 53; 12 of No. 59; 2 of No. 62; 2 of No. 63; 4 of No. 70; 50 of No. 94; 2 of No. 95; 1 of No. 96; 3 of No. 96a; 4 of No. 109; 4 of No. 111a; 1 of No. 111c; 1 of No. 115; 2 of No. 125; 2 of No. 126a; 1 Electric Motor.

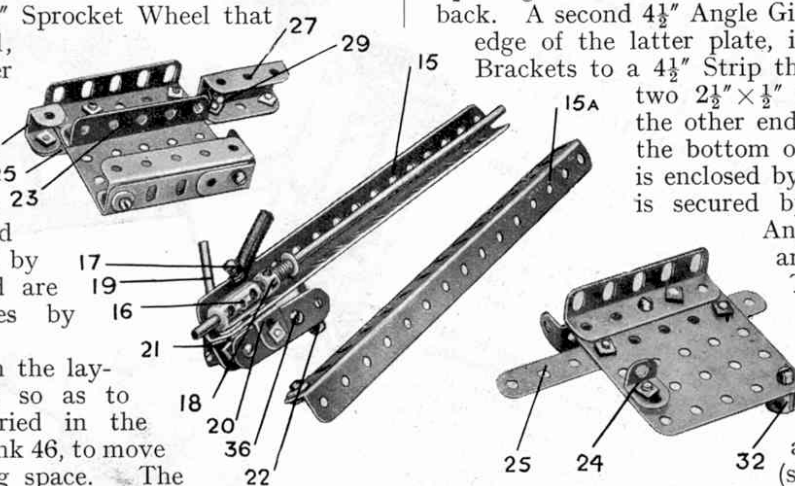

Fig. 6. The Barrel and recoil chamber dismantled. A Washer is shown in position ready for firing.

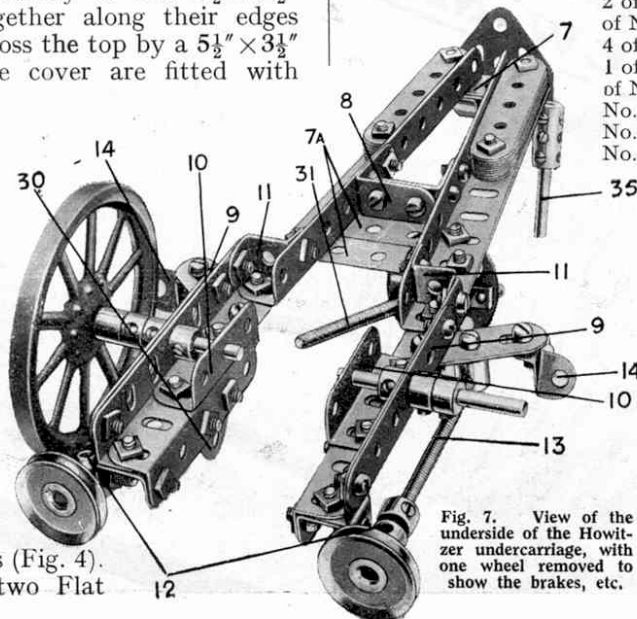

Fig. 7. View of the underside of the Howitzer undercarriage, with one wheel removed to show the brakes, etc.