

# Motor Vehicles in Meccano

## Useful Hints to Model-Builders

A LARGE proportion of the models entered in Meccano Competitions represent motor vehicles, and they range from high-powered streamlined racing cars and luxurious limousines to heavy six-wheeled articulated goods lorries. Usually the bodywork is beautifully built, but the mechanical details of the chassis often are not so well designed as they might be. For example, several cases have come to our notice recently in which the construction of the so-called Ackermann steering gear was

found to be just in front of the back axle. The levers are connected one to the other by a tie rod.

In Meccano practice a slightly different method is adopted, the arrangement being as shown in Fig. 2. Short Rods 11 and 11a are secured just behind the stub axles and arranged to protrude backward. They are connected together by a longer Rod 12, and it will be seen that the imaginary lines AB, CD, drawn through the pivotal mountings of the stub axles and through the points

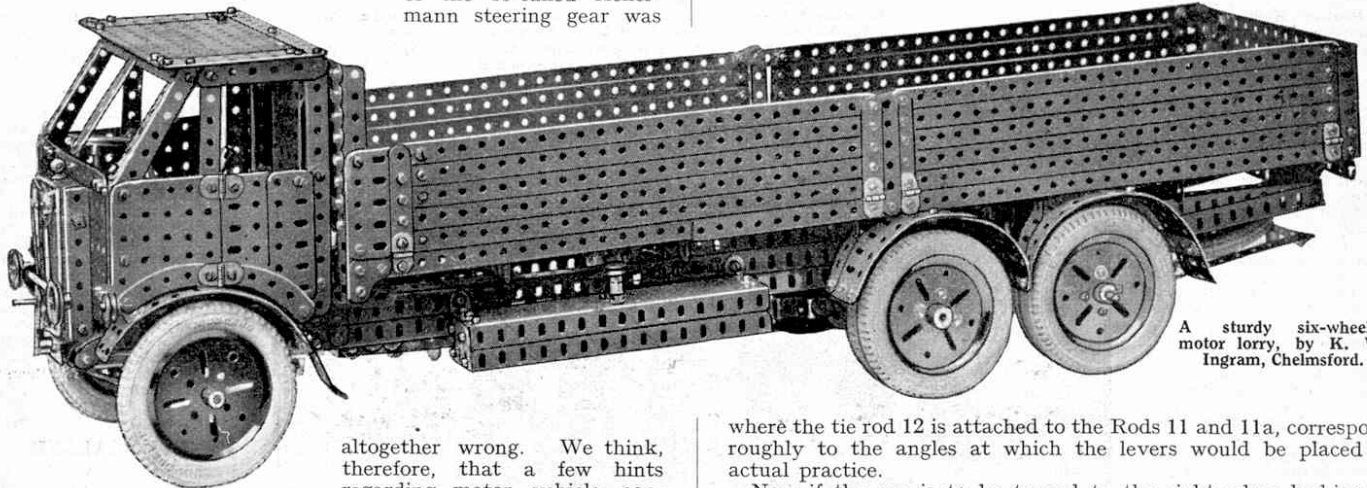

A sturdy six-wheeled motor lorry, by K. W. Ingram, Chelmsford.

altogether wrong. We think, therefore, that a few hints regarding motor vehicle construction in Meccano will be welcomed by the majority of model-builders.

The part of a car chassis on which even the most experienced model-builders often go wrong is the steering mechanism. The standard type of gear fitted to actual motor cars is known as the "Ackermann" gear. We often receive models from constructors who say that their cars are fitted with "Ackermann" gear, but on examination we find that the steering arrangement of the model bears little resemblance to this ingenious mechanism. As a matter of fact Ackermann steering gear can be reproduced with remarkable fidelity in Meccano, and it is therefore all the more surprising that so few constructors are able to assemble it correctly. With the object of clearing up the confusion that exists on this point we will describe and illustrate the Ackermann gear very fully, so that constructors can copy it in their future models.

As most readers will be aware, when a car turns a corner the near side wheels describe a sharper curve than the outer wheels, so that the front wheels have different angularities. Therefore, for the wheels to turn the corner with the least possible friction on the road surface, each must be situated at a tangent to the circle in which it is moving. As both wheels cannot lie at their respective tangents and at the same time remain parallel to each other, it becomes necessary to incorporate in the steering gear some method by means of which a greater angle can be given to the wheel that is nearest to the centre of the circle, no matter whether the car be turning to right or left. This object is achieved by the Ackermann steering gear.

In actual practice, the gear consists essentially of two short levers rigidly connected to the stub axles, and projecting either backward or forward. These levers lie at a slightly obtuse angle to the stub axles, the correct angle being arrived at by fixing the levers so that their centre lines, if produced, would meet on the centre line of the car. The exact meeting place varies according to the size of the car and length of the levers, but as a rule it is

where the tie rod 12 is attached to the Rods 11 and 11a, correspond roughly to the angles at which the levers would be placed in actual practice.

Now if the car is to be turned to the right when looking at the gearing as in the drawing, the road wheel on the stub axle 13 must be deflected in that direction, and the imaginary lever AB will be moved through a certain number of degrees to the left. In so doing it pushes the lever corresponding to CD in our sketch in the same direction, but owing to the difference in angularity between the two levers, lever CD, and therefore the road wheel attached to its stub axle 13a, moves through a lesser number of degrees. If the car moves to the left exactly the opposite occurs, the lever CD moving the lever AB.

This arrangement of the linkage therefore fulfils the essential requirements of the Ackermann steering gear, that is, it imparts a greater angular movement to the inner road wheel when the car turns a corner.

In building model motor vehicles many constructors omit the very important torque rods, which are quite easy to reproduce from standard Meccano parts. The torque rods are intended to counteract the stresses, strains and twisting effort set up by the propeller shaft, which carries the transmission from the gear-box to the back axle. If the transmission is effected by a small bevel on the propeller shaft engaging a second and larger bevel on the back axle, then, when the engine rotates, the small bevel on the propeller shaft will endeavour to rotate the bevel on the back axle. This naturally is somewhat difficult to move, and therefore the small bevel will tend to travel round the large bevel, while the latter remains stationary. This state of affairs might possibly result in a broken propeller shaft or broken springs, owing to the twisting movement imparted to the back axle casing; and it is to

counteract these strains that motor vehicles are fitted with torque rods. Usually the propeller shaft is enclosed in what is known as a torque tube, which not only forms a torque reaction resistance, but also receives the forward thrust of the back axle.

In Meccano models simple torque rods can be made from Strips secured to the ends of a Double Angle Strip. These Strips should taper together at their free ends, and then be secured to a Collar by means of an ordinary bolt inserted in place of the grub screw.

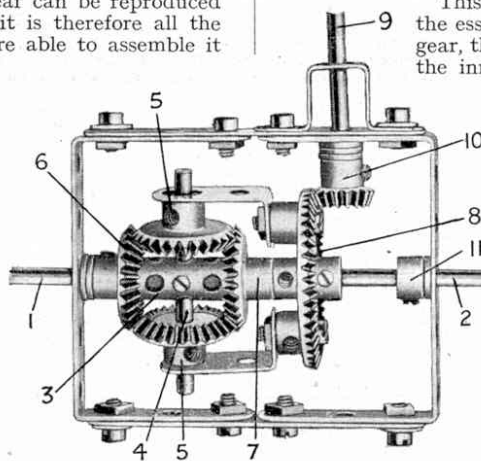

Fig. 1. Meccano differential mechanism suitable for incorporation in all kinds of model motor vehicles.

The Collar is pivoted on a second bolt that is inserted in the grub screw hole of a second Collar capable of turning about a Pivot Bolt secured to a suitable girder in the frame of the chassis.

Another important item in model motor car engineering is the mechanism incorporated in the back axle to allow the outer

driven road wheel to rotate at a higher speed than the inner road wheel when the car turns a corner, and yet at the same time allow the drive to be transmitted evenly and continuously to each wheel. The mechanism that fulfils these functions is known as a "differential" or "balance" gear. In some cars, especially in heavy commercial vehicles, the differential is incorporated in a secondary shaft journaled in the main frame and connected at each end to one of the road wheels by means of chain or belt drive. The object of this is to reduce to a minimum the weight of the back axle, which is subject to a continuous series of road shocks when in motion.

In the standard Meccano model Motor Chassis (Instruction Leaflet No. 1), the differential forms part of the back axle unit and the principle on which the mechanism operates should be clear from Fig. 1 and the following description.

The back axle shaft is in two sections, 1 and 2. Section 1 consists of a 3" Rod and section 2 of a 4 1/2" Rod and a 2" Rod connected end to end by a Coupling as shown. The inner ends of the shafts 1 and 2 are journaled in opposite in the centre transverse hole of 2" Rod 4 that serves to carry Gears 5. The set-screws of

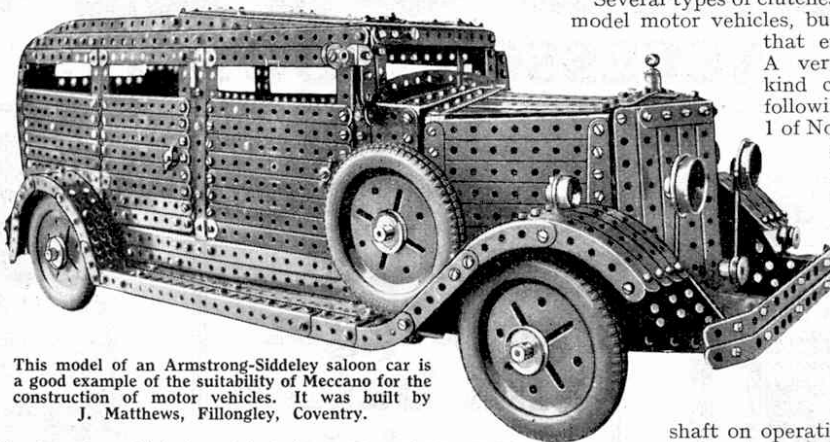

This model of an Armstrong-Siddeley saloon car is a good example of the suitability of Meccano for the construction of motor vehicles. It was built by J. Matthews, Fillongley, Coventry.

in speed between the Bevel Gears 6 and 7. If the vehicle is running in a perfectly straight course the axles 1 and 2 and Bevel Gears 5, 6 and 7 must all rotate as one unit, since the road wheels are travelling at the same speed. This type of differential is suitable for all kinds of model motor vehicles.

Several types of clutches are available to builders of model motor vehicles, but the most popular type is that employing a friction drive. A very efficient clutch of this kind can be built up from the following parts: 2 of No. 12; 1 of No. 20; 1 of No. 22; 2 of No. 37a; 2 of No. 111c; 1 of No. 120b; 1 of No. 155; 1 of No. 165.

The Rubber Ring is fitted in the groove of the 1" Pulley, which is secured to the engine shaft and forms the male portion of the clutch. The other clutch member is the 1 1/8" Flanged Wheel. This is arranged to move to and fro on the gear-box

shaft on operation of the clutch pedal, and is thus brought into or out of contact with the Rubber Ring, which is driven continuously from the engine.

This type of clutch is incorporated in the standard Meccano Motor Chassis, and full constructional details and illustrations of the unit are contained in Special Instruction Leaflet No. 1.

No difficulty should be experienced in building a suitable gear-box for a model from the splendid assortment of gears that form so valuable a feature of the Meccano model-building system.

There are indeed very few gear designs that cannot successfully be imitated in a Meccano motor car, and the wide range of ratios afforded by the various sizes of gears available makes the building of a gear-box a task full of interest and endless possibilities for experiment. In connection with the gear-box, part No. 144, Dog Clutch, will some-

times be found useful, although in a very small model its large size will prohibit its use. The Standard Mechanisms Manual will be found very helpful in designing gear-boxes.

So far as the bodywork of a model motor vehicle is concerned, little need be said, for as will be seen from the fine models on this and the opposite page, really wonderful results can easily be obtained.

The realism of a model depends to a large extent on the judicious use of the various parts incorporated in it. For example, the Pawl (part No. 147) can be used to represent the familiar pattern door handles on saloon cars, with perfect results. The Fan (part No. 157) also is valuable for use in this type of work, for it can be used with excellent effect as a radiator cooling fan.

Many of the newer Meccano parts are particularly well suited for this kind of model-building, and we have seen good use made of Handrail Supports, Channel Bearings and Curved Strips, the last-named being frequently employed for shaping the wing edges and moulding the contours of saloon bodies. Other parts useful in this kind of work are the Meccano Dunlop Tyres.

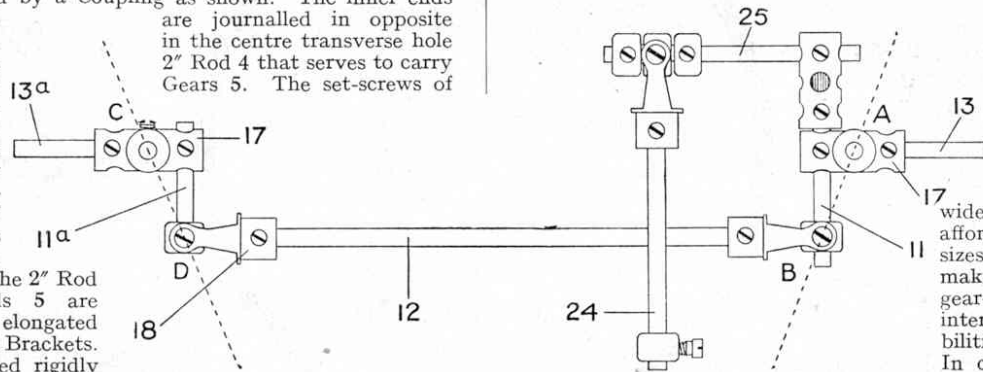

Fig. 2. Plan of Ackermann type steering mechanism.

The outer ends of the 2" Rod carrying the Bevels 5 are passed through the elongated holes of 1" x 1/2" Angle Brackets. The latter are secured rigidly by means of 1/2" Bolts to opposite holes in the 1 1/2" Bevel Gear 8, and are spaced from it by means of Collars placed on the bolts between the Brackets and the Bevel Gear. This Bevel Gear is free to revolve independently about the axle shaft 2, its set-screw having been removed.

The propeller shaft consists of a 3 1/2" Rod 9, one end of which is secured in a Universal Joint. The other end, after passing through a Double Bent Strip and the side of the differential frame, is secured in the 1/2" Bevel Gear 10, which engages with the 1 1/2" Bevel Gear 8. Two Collars 11 are secured to the shafts 1 and 2 in the positions shown to maintain the various gears in correct alignment and to prevent the gears 8 and 10 from slipping or binding against each other. A Washer is placed between the outer Collar 11 and the Double Angle Strip forming the end of the differential frame, and two Washers are placed against the boss of the 1/2" Bevel Gear 6.

Everything should operate smoothly and easily when the shafts 1 and 2 are twisted between thumb and finger, whether simultaneously and in the same direction, or separately and in opposite directions.

If one of the road wheels revolves at a greater speed than the other, the Bevel Gears 5 begin to rotate and so adjust the difference

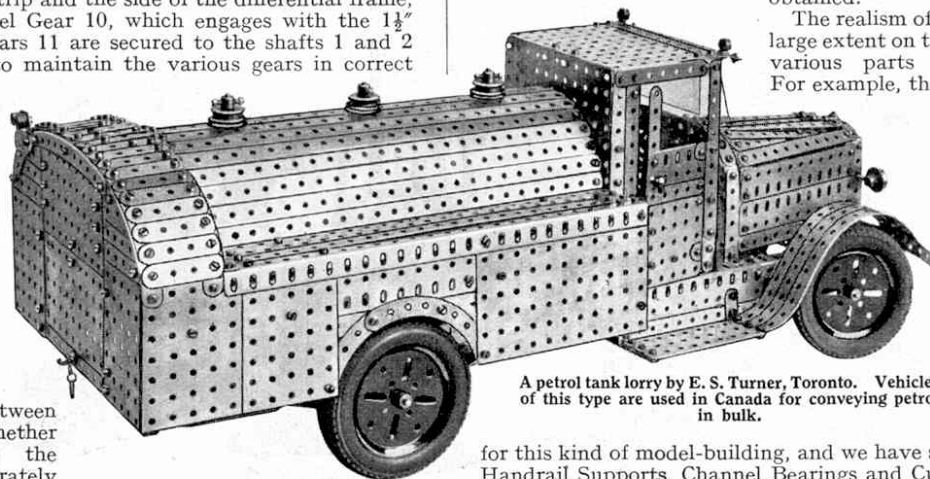

A petrol tank lorry by E. S. Turner, Toronto. Vehicles of this type are used in Canada for conveying petrol in bulk.

for this kind of model-building, and we have seen good use made of Handrail Supports, Channel Bearings and Curved Strips, the last-named being frequently employed for shaping the wing edges and moulding the contours of saloon bodies. Other parts useful in this kind of work are the Meccano Dunlop Tyres.