

If you wish to build this fine model Car Transporter, write to the Editor for details and list of parts.

MODEL OF THE MONTH:

Fig. 1.

Car Transporter

THINGS that run on wheels are among the most popular of all subjects for Meccano model-builders, so the model we have chosen for the April Model of the Month is one that is sure to appeal to practically every Meccano enthusiast.

Nowadays vehicles tend to be more specialised in their uses than was the case previously, and there are many examples of vehicles designed specially for carrying loads of particular kinds. Our model is based on one of these specialised vehicles that is exceptionally interesting in design and operation. It is a car transporter, and model-builders who are also Dinky Toys enthusiasts will be familiar already with this vehicle, for an attractive miniature is included in the range of Dinky Toys.

Since the war, manufacturers in the United Kingdom have been asked to export more and more of their products, and the motor car industry has been outstandingly successful in this respect. The volume of car exports has risen continually, despite ever increasing competition from other countries, and readers living near seaports must be familiar with the sight of new cars in special protective finishes heading for the docks. Sometimes these new cars are driven under their own power, but very often they are loaded in groups on special transporters that carry them

speedily and economically to their destination.

Our model is based on a typical car transporter designed to carry a load of up to four cars. It is an articulated vehicle, that is, the prime mover or tractor is not provided with a fixed loading platform. Instead the load carrier is a special semi-trailer with wheels at the rear end only. This is pivotally attached to the

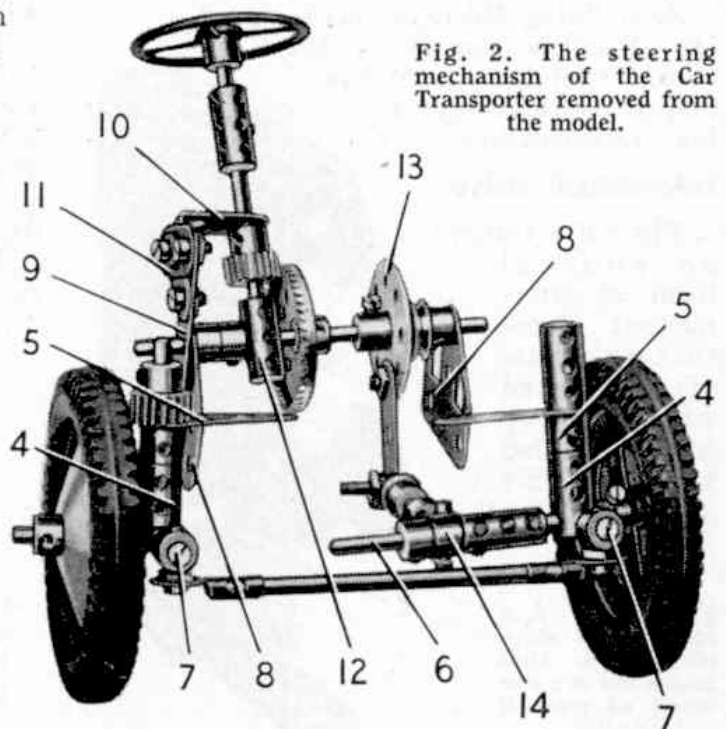
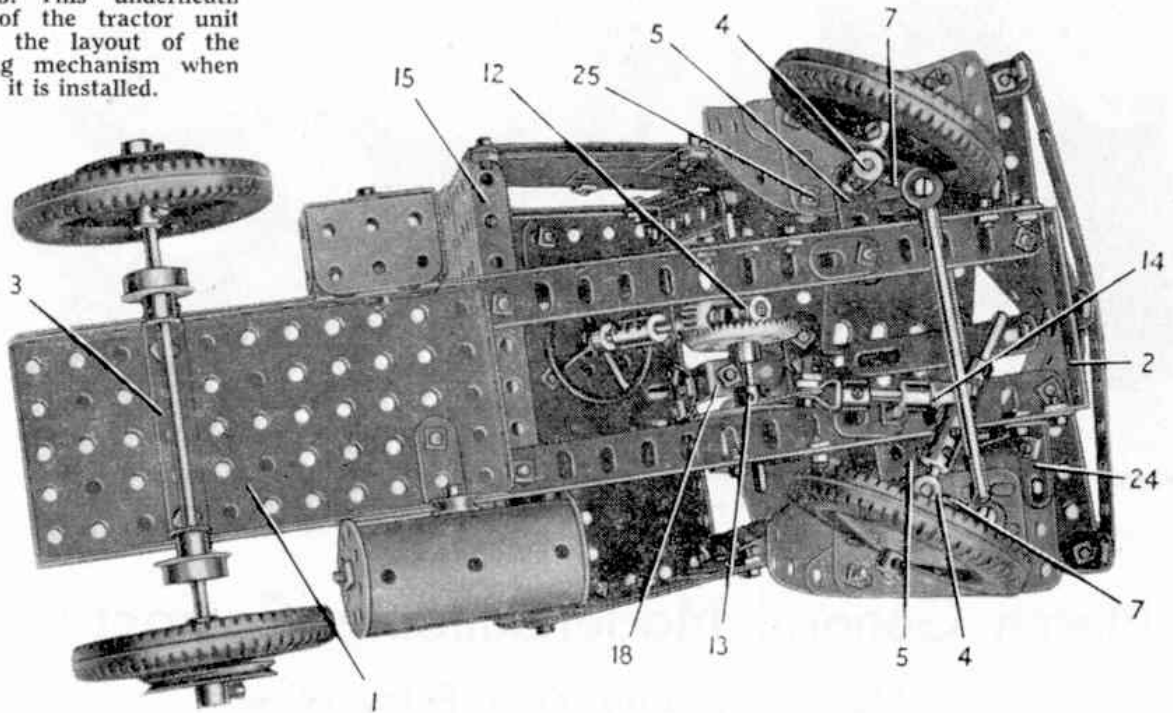

Fig. 2. The steering mechanism of the Car Transporter removed from the model.

Fig. 3. This underneath view of the tractor unit shows the layout of the steering mechanism when it is installed.



chassis of the tractor so that the complete vehicle is readily manoeuvrable.

The semi-trailer has two load platforms or decks, placed one above the other. A hinged ramp is attached to the lower deck, and when this ramp is lowered two cars can be driven up it on to the deck, where they are clamped in position. The upper deck also is designed to carry two cars, but it is not provided with a self-contained loading ramp as in the case of the lower deck. Instead the vehicle can be backed up to a special loading platform of the

correct height, or the cars can be hoisted in place by means of cranes. On arrival at the unloading point cranes are usually available if necessary to remove the cars.

The Meccano model is designed for construction with a No. 8 Outfit, and it follows the design of the real vehicle as closely as possible. Detailed instructions are not included in these pages. Meccano enthusiasts who wish to build the model should write to the Editor for full constructional details and a list of the parts required.

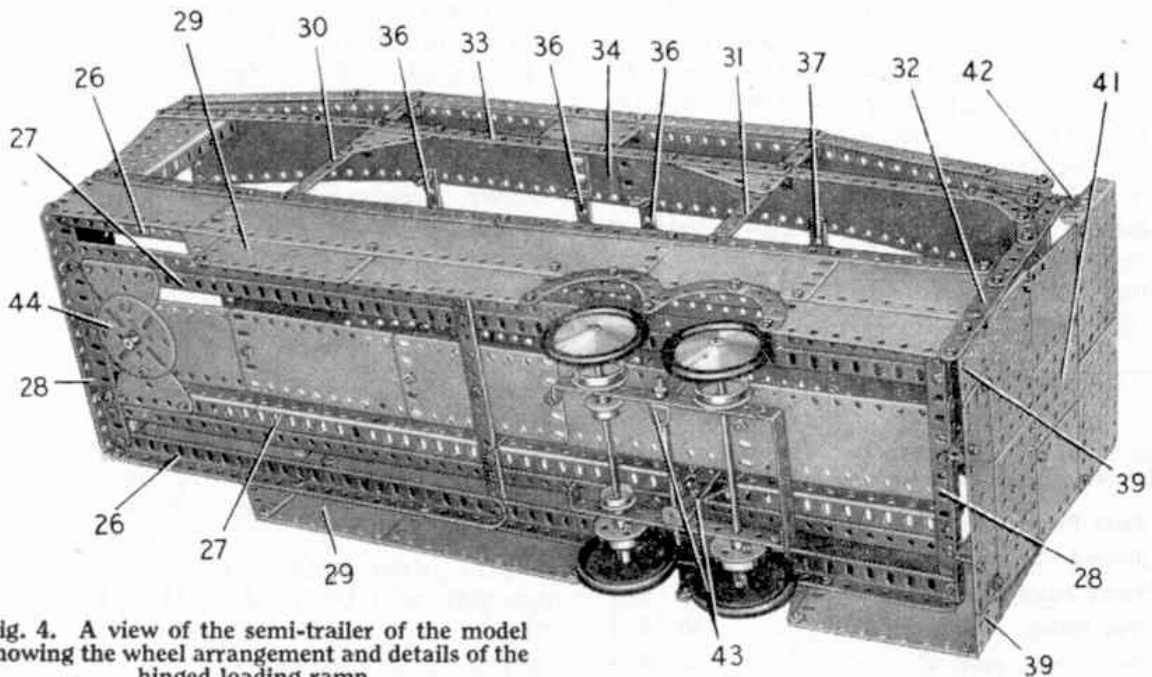

Fig. 4. A view of the semi-trailer of the model showing the wheel arrangement and details of the hinged loading ramp.

CAR TRANSPORTERMotor Chassis and Steering Mechanism

The chassis consists of two $12\frac{1}{2}$ " Angle Girders bolted to the sides of a $5\frac{1}{2}$ " x $2\frac{1}{2}$ " Flanged Plate 1 (Fig. 3) and connected at their front ends by a $2\frac{1}{2}$ " x $\frac{1}{2}$ " Double Angle Strip 2. The rear axle is a $6\frac{1}{2}$ " Rod supported in a $2\frac{1}{2}$ " x 1" Double Angle Strip 3 bolted across the Flanged Plate 1. The Conical Discs of the rear wheels are held in place by $1\frac{1}{2}$ " Pulleys.

The steering mechanism is shown removed from the chassis in Fig. 2. Each of the front wheel axles is fixed in the lower cross bore of a Coupling 4 mounted on a $1\frac{1}{2}$ " Rod. These Rods pass freely through the bosses of Cranks 5, and one Rod is held in place by a $\frac{1}{2}$ " Pinion and the other by a Coupling. One of the front wheel axles is a $3\frac{1}{2}$ " Rod 6 and the other is a $1\frac{1}{2}$ " Rod. The front wheels are mounted freely on the Rods and are held in place by Collars.

A $\frac{3}{4}$ " Bolt 7 is screwed tightly into each of the Couplings 4, and Collars are fastened against the heads of the Bolts. A Rod and Strip Connector is pivotally mounted on a bolt fixed by a nut in each of the Collars. The Rod and Strip Connectors are linked together by a $3\frac{1}{2}$ " Rod. The Cranks 5 are bolted tightly to the chassis.

Two Flat Trunnions 8 are fixed to the chassis, and one of them supports a $2\frac{1}{2}$ " Strip 9. A 1" x 1" Angle Bracket 10 is bolted to the Strip 9, and is connected to it also by a Fishplate 11. A $3\frac{1}{2}$ " Rod is mounted in the Flat Trunnions 8 and carries two Collars, a Coupling 12 mounted freely, a $1\frac{1}{2}$ " Contrate, a Bush Wheel 13 and a $\frac{1}{2}$ " fixed Pulley. The steering column is made from a 2" and a 1" Rod joined by a Coupling, and it carries a $\frac{1}{2}$ " Pinion that engages the $1\frac{1}{2}$ " Contrate.

A $1\frac{1}{2}$ " Strip is bolted tightly to the Bush Wheel 13 and an End Bearing is lock-nutted at its end. A 1" Rod is fixed in the End Bearing and in a Swivel Bearing 14 that pivots on the Rod 6 between a Collar and a Coupling.

The petrol tank at one side of the chassis is a Cylinder that is bolted to a 1" x 1" Angle Bracket but is spaced from it by a $\frac{1}{2}$ " loose Pulley on a $\frac{3}{8}$ " Bolt. A Wheel Disc is fixed to each end of the Cylinder by nuts on a Screwed Rod. The tool box at the other side of the chassis is a Channel Bearing fitted with two 1" x 1" Angle Brackets and attached to a Trunnion bolted to the chassis.

Construction of the Cab and Bonnet

The lower part of the back of the cab is a $5\frac{1}{2}$ " x $2\frac{1}{2}$ " Flanged Plate 15, (Fig. 3), extended upward by a $5\frac{1}{2}$ " x $1\frac{1}{2}$ " and two $5\frac{1}{2}$ " x $2\frac{1}{2}$ " Flexible Plates that overlap the Flanged Plate by two holes. The upper ends of the Flexible Plates are curved forward to form part of the roof.

Each side of the cab consists of two $2\frac{1}{2}$ " x $2\frac{1}{2}$ " Flexible Plates overlapped four holes, and a $2\frac{1}{2}$ " x $1\frac{1}{2}$ " Triangular Flexible Plate 16, edged by a $5\frac{1}{2}$ " Strip 17 and a $3\frac{1}{2}$ " Strip. A 3" Strip is bolted to the lower end of the Strip 17 and is connected to the Flexible Plates by a Fishplate. The window frame is formed by two 3" Strips. The upper ends of the Strips 17 are connected to the back of the cab by Angle Brackets.

The top edge of the windscreen frame consists of two $2\frac{1}{2}$ " Strips joined at the centre by a 1" Triangular Plate and attached to the side window frames by Angle Brackets. The centre windscreen division is a 1" x 1" Angle Bracket 18. The front of the cab roof is formed by two 1 $11/16$ " radius Curved Plates and a curved $2\frac{1}{2}$ " x $1\frac{1}{2}$ " Flexible Plate

bolted to the top of the windscreen and to the ends of the Flexible Plates used for the back of the cab.

Each side of the bonnet is a $5\frac{1}{2}$ " x $1\frac{1}{2}$ " Flexible Plate edged along the top by a $5\frac{1}{2}$ " Strip and at the front by a $2\frac{1}{2}$ " Strip. The radiator consists of two curved $5\frac{1}{2}$ " x $1\frac{1}{2}$ " Flexible Plates 19 fitted with a vertical $2\frac{1}{2}$ " Strip and three Formed Slotted Strips. The top of the bonnet is filled in by two $1\frac{11}{16}$ " radius Curved Plates and two curved $2\frac{1}{2}$ " x $1\frac{1}{2}$ " Flexible Plates. These are bolted at the front to a $3\frac{1}{2}$ " Strip 20, and are connected to this Strip by Fishplates held by Bolts 21. The top of the bonnet is connected to the radiator by a Formed Slotted Strip 22, and is supported at the rear by the Angle Bracket 18.

Each front mudguard consists of a $2\frac{1}{2}$ " x $1\frac{1}{2}$ " Flexible Plate, a $2\frac{1}{2}$ " x $1\frac{1}{2}$ " Triangular Flexible Plate and a $3\frac{1}{2}$ " x 2" Triangular Flexible Plate, curved as shown. These Plates are edged on the inside by a curved $3\frac{1}{2}$ " Strip 23, and are attached to the chassis by a 1" x $\frac{1}{2}$ " Angle Bracket 24 and to the side of the bonnet by an Angle Bracket held by Bolt 25.

The headlamps are Chimney Adaptors fixed to Angle Brackets, which are held by nuts on the ends of a Screwed Rod passed through the sides of the bonnet.

The front bumper consists of two $5\frac{1}{2}$ " Strips overlapped nine holes and connected by Angle Brackets to $2\frac{1}{2}$ " Strips bolted to the front of the chassis.

Assembly of the Trailer

The lower deck of the trailer consists of four built-up angle girders, indicated at 26 and 27 (Fig. 4), each made from two $12\frac{1}{2}$ " Angle Girders joined together. These girders are connected at each end by a built-up girder 28, made from two $5\frac{1}{2}$ " Angle Girders overlapped seven holes, and at the centre by two $5\frac{1}{2}$ " Strips also overlapped seven holes. Two $12\frac{1}{2}$ " Strips are bolted between the girders 26 and 27 on each side, and along the centre of the deck are bolted four $5\frac{1}{2}$ " x $2\frac{1}{2}$ " and two $2\frac{1}{2}$ " x $2\frac{1}{2}$ " Flexible Plates, which are strengthened at the centre by two $12\frac{1}{2}$ " Strips.

Each side of the lower deck is made by bolting two $5\frac{1}{2}$ " x $2\frac{1}{2}$ " Flexible Plates, a $4\frac{1}{2}$ " x $2\frac{1}{2}$ " Flexible Plate and a $12\frac{1}{2}$ " x $2\frac{1}{2}$ " Strip Plate to the flange of the girder 26. The top edges of the Plates are strengthened by two $12\frac{1}{2}$ " Strips, and the side is extended downward by a $2\frac{1}{2}$ " x $2\frac{1}{2}$ " Triangular Flexible Plate, one half of a Hinged Flat Plate 29, a $5\frac{1}{2}$ " x $2\frac{1}{2}$ " Flexible Plate and a $4\frac{1}{2}$ " x $2\frac{1}{2}$ " Flexible Plate. The wheel arches are made from $2\frac{1}{2}$ " Stepped Curved Strips.

The top deck is supported on each side by a Flanged Sector Plate at the front, and by built-up strips 30, 31 and 32. The strip 30 consists of a $5\frac{1}{2}$ " Strip and a $2\frac{1}{2}$ " x $\frac{1}{2}$ " Double Angle Strip overlapped two holes; strip 31 is made from a $4\frac{1}{2}$ " x $\frac{1}{2}$ " Double Angle Strip and a $2\frac{1}{2}$ " Strip bolted together, and strip 32 is formed from two $4\frac{1}{2}$ " Strips overlapped three holes. The strips 30, 31 and 32, and the Flanged Sector Plate, are connected by a built-up strip 33, made from a $12\frac{1}{2}$ ", two $5\frac{1}{2}$ " and two $2\frac{1}{2}$ " Strips.

The side rails of the top deck are each formed by a $12\frac{1}{2}$ ", a $2\frac{1}{2}$ ", a 2" and two $5\frac{1}{2}$ " Strips arranged as shown. The side rail is connected to the strip 33 by a $1\frac{1}{2}$ " Strip at each end, and by a $2\frac{1}{2}$ " x $2\frac{1}{2}$ " Flexible Plate at the centre.

The floor of the top deck on each side consists of two $12\frac{1}{2}$ " x $2\frac{1}{2}$ " Strip Plates placed one on each side of a $2\frac{1}{2}$ " x $2\frac{1}{2}$ " Flexible Plate 34. These Plates are connected to the side rails by Angle Brackets. The Plates on each side are connected at the rear by a $5\frac{1}{2}$ " and a $4\frac{1}{2}$ " Strip overlapped five holes, and at the front by a $4\frac{1}{2}$ " Strip 35 extended at each side by a Corner Gusset. The Plates at the sides of the top deck are joined by three $3\frac{1}{2}$ " x $\frac{1}{2}$ " Double Angle Strips 36 and a $3\frac{1}{2}$ " Strip 37.

Two $5\frac{1}{2}$ " x $1\frac{1}{2}$ " Flexible Plates 38 are bolted to a $2\frac{1}{2}$ " x $2\frac{1}{2}$ " Flexible Plate at each side, and this assembly is fixed to the girder 28 at the front and to the flanges of the Flanged Sector Plates. At the rear two $2\frac{1}{2}$ " x $1\frac{1}{2}$ " Flanged Plates 39, connected by a $5\frac{1}{2}$ " x $1\frac{1}{2}$ " Flexible Plate, are bolted between the sides of the lower deck.

The hinged ramp is made by bolting four $3\frac{1}{2}$ " x $2\frac{1}{2}$ " Flanged Plates together in pairs, and the two pairs are connected by a $5\frac{1}{2}$ " Strip 40 placed between the inner flanges of the Plates so that it overlaps each pair by three holes. Two $4\frac{1}{2}$ " x $2\frac{1}{2}$ " Flexible Plates and a $3\frac{1}{2}$ " x $2\frac{1}{2}$ " Flanged Plate 41 are fixed together as shown and are bolted between the pairs of Flanged Plates. A Fishplate is fixed to each side of the lower end of the ramp by its round hole, and the slotted holes of the Fishplates are passed over Threaded Pins attached to the strips 32. A $\frac{3}{8}$ " Bolt is held by a nut at each side of the upper end of the ramp. These Bolts can be engaged behind Fishplates 42 to keep the ramp in its travelling position.

The trailer wheels are fixed as shown in Fig. 4 on $6\frac{1}{2}$ " Rods mounted in two $5\frac{1}{2}$ " x $\frac{1}{2}$ " Double Angle Strips, which are connected at one end by a $3\frac{1}{2}$ " x $\frac{1}{2}$ " Double Angle Strip. The trailer bogie pivots on a $4\frac{1}{2}$ " Rod supported in $2\frac{1}{2}$ " x $\frac{1}{2}$ " Double Angle Strips 43. These are bolted to the girders 27 and are strengthened by Flat Trunnions.

A Face Plate 44 is attached to Semi-Circular Plates bolted to the girders 27. The boss of the Face Plate is fitted over a $1\frac{1}{2}$ " Rod held in a second Face Plate that is fixed to the Flanged Plate 1 of the motor unit. The two Face Plates are separated by a Spring Clip on the Rod.

Parts Required

14 of No. 1	4 of No. 20b	10 of No. 59	1 of No. 185
21 " " 2	2 " " 21	2 " " 62	4 " " 187
6 " " 2a	1 " " 23	6 " " 63	4 " " 187a
6 " " 3	1 " " 23a	1 " " 77	7 " " 188
6 " " 4	1 " " 24	1 " " 80a	8 " " 189
18 " " 5	2 " " 24a	1 " " 80c	10 " " 190
2 " " 6	2 " " 26	4 " " 90	6 " " 191
5 " " 6a	1 " " 28	8 " " 90a	12 " " 192
10 " " 8	1 " " 35	2 " " 108	6 " " 197
4 " " 9	280 " " 37a	2 " " 109	1 " " 198
14 " " 10	259 " " 37b	3 " " 111	4 " " 200
24 " " 12	32 " " 38	6 " " 111a	2 " " 212
5 " " 12a	2 " " 38d	6 " " 111c	2 " " 214
2 " " 12b	1 " " 46	2 " " 115	4 " " 215
3 " " 14	7 " " 48a	1 " " 126	1 " " 216
1 " " 15a	4 " " 48b	4 " " 126a	4 " " 221
3 " " 16	2 " " 48c	4 " " 142a	2 " " 222
1 " " 17	2 " " 48d	1 " " 147b	2 " " 223
4 " " 18a	2 " " 51	1 " " 160	2 " " 224 ✓
2 " " 18b	2 " " 52	2 " " 164	2 " " 225 ✓
4 " " 20	5 " " 53	2 " " 165	
4 " " 20a	2 " " 54	1 " " 166	