

## MODEL OF THE MONTH

# Wall Clock

**WORKING** models, especially those that serve a useful purpose when they are completed, appeal to every model builder, and our latest "Model of the Month" is one that is sure to create a lot of interest. It is a weight-operated Wall Clock and is based on a model entered in a Meccano Competition some time ago by Mr. R. B. Bagshaw, London S.E.26.

Since the very earliest days of the Meccano hobby enthusiasts have been fascinated by the construction of working clocks, and to judge by the requests we receive for details of such models the interest in Meccano clock mechanisms is increasing steadily.

The construction of a really satisfactory clock is a challenge to even an experienced model-builder, for absolute accuracy in assembly is essential if reliable timekeeping is to be obtained. It is a real thrill to complete a model of this kind and set it working, and we are sure every enthusiast who builds this "Model of the Month" will feel a sense of achievement as he watches the pendulum swing to and fro and listens to the steady beat of the escapement.

The clock is designed to hang on a wall, and as illustrated it consists of little more than a frame for the mechanism and the clock face. This form of construction has been adopted deliberately, as we think that most model-builders will want to demonstrate the working of the model to their families and friends. The model as illustrated is neat and effective in appearance, but if desired the frame can be enclosed in a case quite easily, and no changes in the design of the mechanism should be necessary.

The Wall Clock is operated by a weight of between  $4\frac{1}{2}$  and 5 lb. suspended from a length of Sprocket Chain that passes round a  $1\frac{1}{2}$ " Sprocket Wheel. The Sprocket Wheel is the driving member of the clock gear train, and it is connected to its shaft by a neat ratchet mechanism. The ratchet

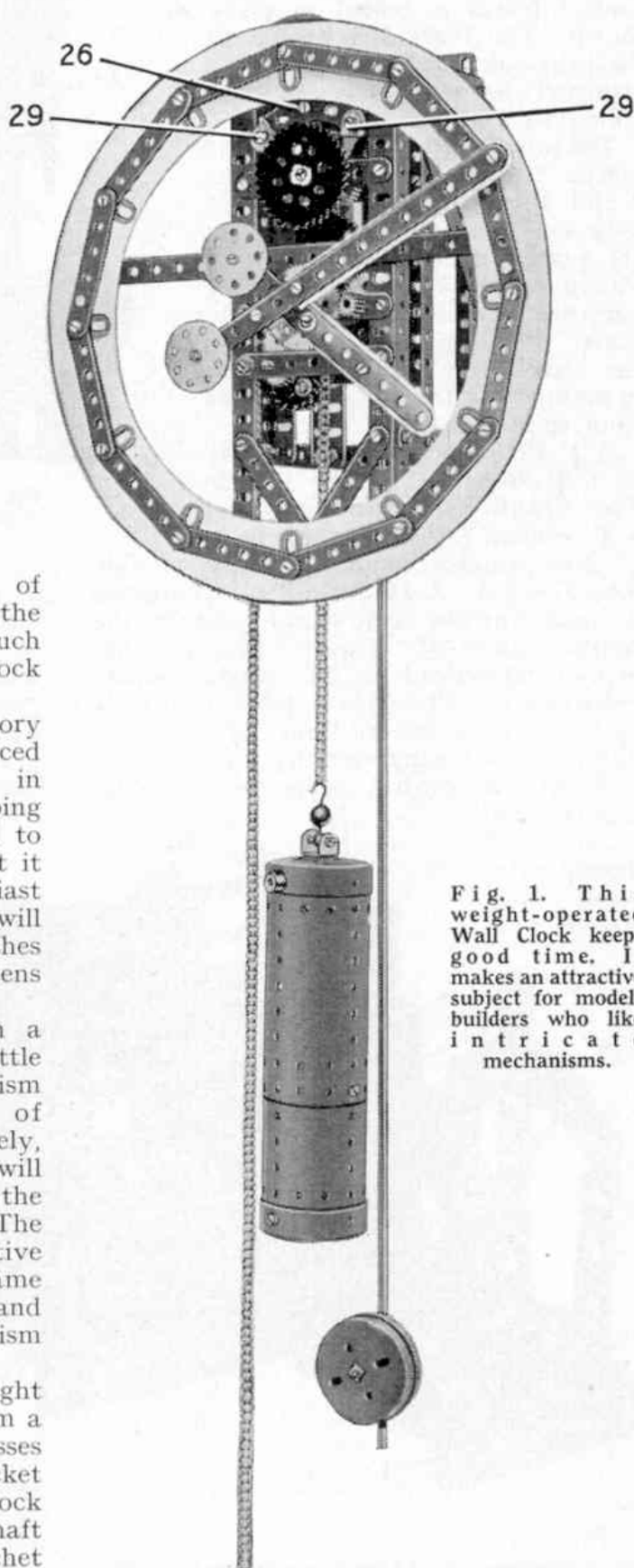

Fig. 1. This weight-operated Wall Clock keeps good time. It makes an attractive subject for model-builders who like intricate mechanisms.

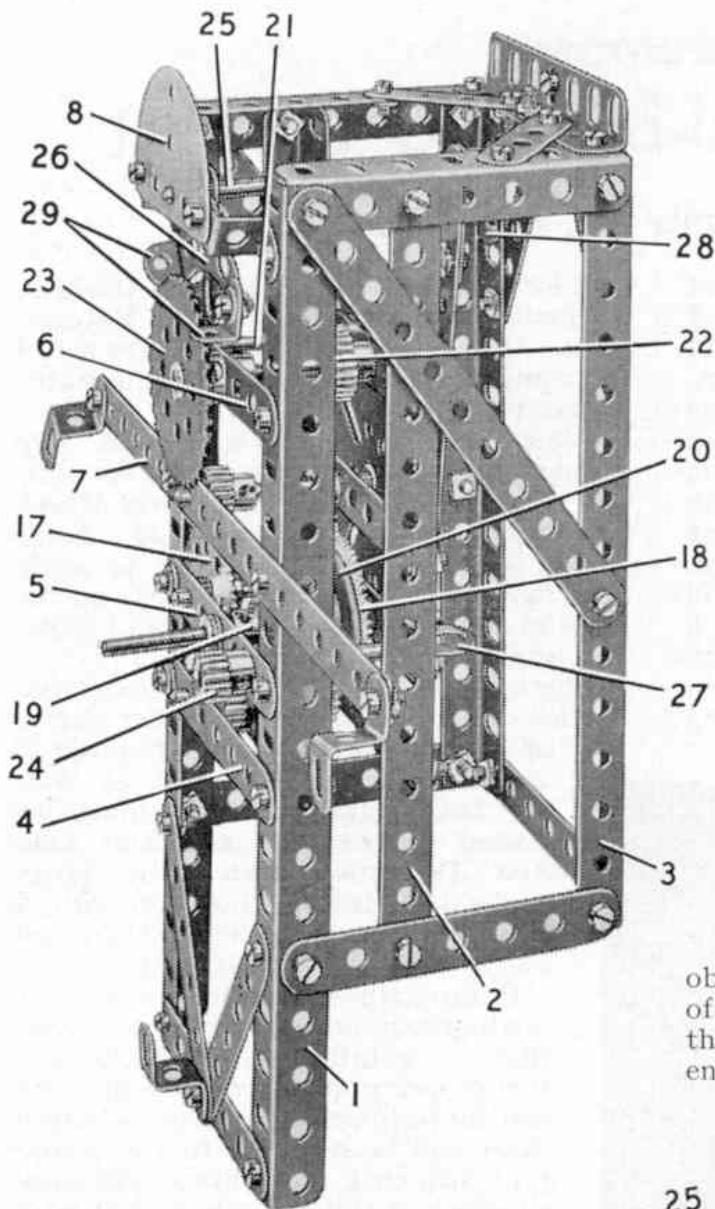

Fig. 2 (above). A side view of the clock mechanism revealing details of the frame and the bearings for the gear shafts.

arrangement allows the Chain to be pulled round to raise the weight without affecting the main gear train. Thus winding the clock is a simple matter, and as a slip clutch is included in the drive to the hands, these can be adjusted while the mechanism is working.

The escapement mechanism is the heart of the clock and in this Wall Clock a 2" Sprocket is used for the escapement wheel. This ensures that the escapement teeth are evenly spaced, a matter that is not easy to arrange when a built-up escapement wheel is used. The adjustment of the pallet of the mechanism is critical, but once the correct setting has been obtained the clock will operate smoothly and steadily. The time-keeping of the mechanism can be varied by adjusting the position of the bob weight on the pendulum.

Full constructional details and a list of the parts required to build the Wall Clock can be obtained by writing to the Editor, enclosing a 2d. stamp for return postage. Readers living in Canada, Australia, New Zealand, South Africa, Ceylon, Italy, Rhodesia, and the United States of America can obtain their copies of the *current* Model of the Month Instructions by writing to the main Meccano agents in those countries, enclosing suitable stamps for postage.

Fig. 3 (right). This close-up picture of the clock gearing shows the arrangement of the ratchet winding mechanism.

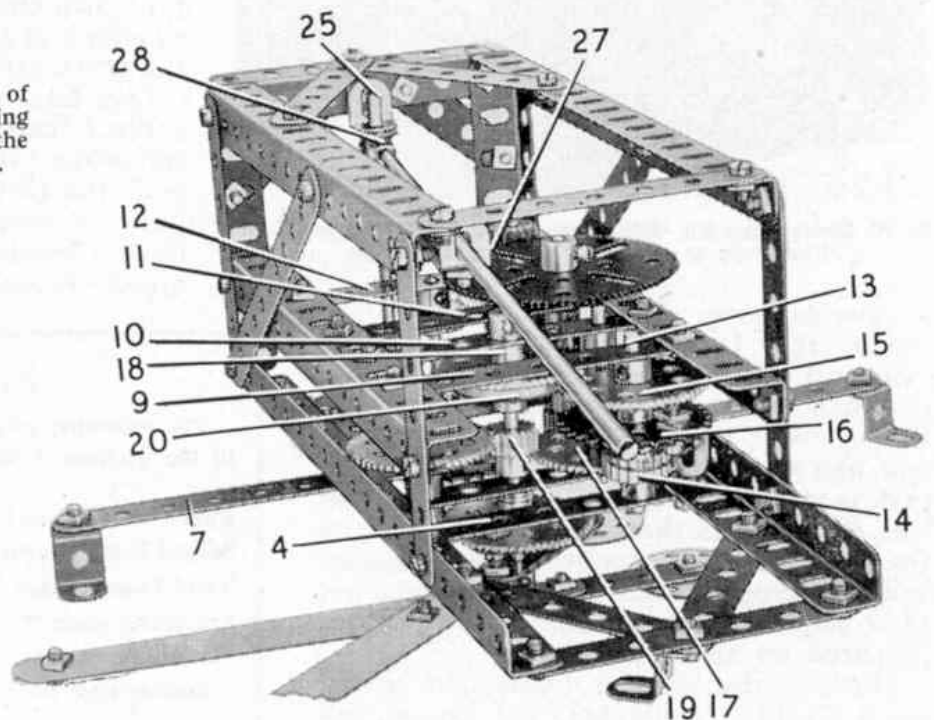

## MODEL OF THE MONTH

### WALL CLOCK

Illustrated in the September 1957 issue of the "Meccano Magazine"

#### The Clock Frame

Each side of the frame consists of a  $9\frac{1}{2}$ " Angle Girder 1, a  $7\frac{1}{2}$ " Angle Girder 2 and a  $7\frac{1}{2}$ " Angle Girder 3 connected at their upper ends by a  $3\frac{1}{2}$ " Angle Girder, and level with the lower ends of the  $7\frac{1}{2}$ " Angle Girders by a  $3\frac{1}{2}$ " Strip. The side is braced by a  $5\frac{1}{2}$ " Strip.

The sides are connected by four  $3\frac{1}{2}$ " Strips and a  $9\frac{1}{2}$ " Strip bolted between the Girders 1. Three of the  $3\frac{1}{2}$ " Strips are numbered 4, 5 and 6, and the  $9\frac{1}{2}$ " Strip is indicated at 7. The upper ends of the Girders 3 are connected by a  $3\frac{1}{2}$ " Angle Girder, with 2" Strips bolted between it and the  $3\frac{1}{2}$ " Angle Girders of the sides. The lower ends of the Girders 3 are connected by a  $3\frac{1}{2}$ " Strip, and  $3\frac{1}{2}$ " Strips are arranged between the Girders 3 and the upper  $3\frac{1}{2}$ " Angle Girder to brace the rear of the frame. The front of the frame is braced by 3" Strips bolted to the Girders 1 and to the  $3\frac{1}{2}$ " Strip used to connect their lower ends.

A Semi-Circular Plate 8 is attached to  $\frac{1}{2}$ " Reversed Angle Brackets bolted to the Girders 1. Four  $3\frac{1}{2}$ " Strips numbered 9, 10, 11 and 12, are fixed between the Girders 2.

#### Arrangement of the Gearing

The driving shaft is a 2" Rod 13 mounted in the Strips 4 and 9. The Rod carries a Ratchet Wheel 14 and a 57-tooth Gear 15 fixed in place, with a loosely mounted  $1\frac{1}{2}$ " Sprocket 16 placed between them. An Angle Bracket is lock-nutted to the Sprocket Wheel but is spaced from it by a Washer. A short length of wire is cut from a Heald, and is shaped so that when one end is bolted to the Sprocket 16, the other end passes through the free hole in the Angle Bracket and presses the latter part against the teeth of the Ratchet Wheel 14. The piece of Heald acts as a light spring and can be replaced by a length of spring wire if desired.

The Gear 15 drives a  $\frac{1}{2}$ " Pinion on a 2" Rod that carries also a 57-tooth Gear 17. The  $\frac{1}{2}$ " Pinion engages another 57-tooth Gear 18 on a 3" Rod fitted with a  $\frac{1}{2}$ " Pinion 19. The Gear 18 is loose on the Rod, but a 1" Pulley 20 fitted with a Rubber Ring is pressed against the Gear to provide a light friction drive.

The Gear 17 drives a  $\frac{1}{2}$ " Pinion on a  $2\frac{1}{2}$ " Rod mounted in Strips 7 and 11 and held in place by a Collar. The  $2\frac{1}{2}$ " Rod carries a  $2\frac{1}{2}$ " Gear that engages a  $\frac{1}{2}$ " Pinion on a  $2\frac{1}{2}$ " Rod 21 supported in the Strips 6 and 12. A 50-tooth Gear on Rod 21 drives a  $\frac{3}{4}$ " Pinion 22 on a 2" Rod that also is mounted in Strips 6 and 12. The last-mentioned Rod carries a 2" Sprocket 23 that forms the escapement wheel.

It should be noted that Washers are placed at suitable positions on the Rods to ensure that the various Gears and Pinions do not rub against the frame or each other. The exact positions and the number of Washers used are best found by experiment, as individual models may vary slightly in this respect. It is essential for the complete gear train to be perfectly free-running, and it is advisable to duplicate the grub screws in the Gears and Pinions in the main gear train to avoid any tendency to slip.

### Details of the Hands

The hour hand is a  $5\frac{1}{8}$ " Strip bolted to a Single Bent Strip that is fixed to a 60-tooth Gear. A Wheel Disc is attached to one end of the Strip, and a piece of white cardboard can be bolted to the other end to outline the hand. The 60-tooth Gear is mounted freely on the 3" Rod that carries the Pinion 19, and it engages a  $7/16$ " Pinion 24 on a 2" Rod mounted in the Strips 5 and 10. A 57-tooth Gear on the 2" Rod meshes with the  $\frac{1}{2}$ " Pinion 19. This gearing provides a 12:1 ratio between the 3" Rod and the 60-tooth Gear that carries the hour hand.

The minute hand is a  $7\frac{1}{8}$ " Strip bolted to a Double Arm Crank, which is fixed at the end of the 3" Rod. The Strip is fitted with a Wheel Disc and can be outlined with white cardboard in the same way as the hour hand.

The friction drive between the Pulley 20 and the Gear 18 allows the hands to be moved without affecting the main gear train.

### The Escapement Mechanism

A 4" Rod 25 is mounted in the Semi-Circular Plate 8 and in an Angle Bracket attached to the rear of the clock frame by a  $\frac{3}{8}$ " Bolt. The Angle Bracket should be spaced from the frame by Washers until Rod 25 is horizontal. Two Cranks are fixed to the Rod so that they hang vertically. One of the Cranks carries a  $2\frac{1}{2}$ " Stepped Curved Strip 26 and the other supports a  $5\frac{1}{2}$ " Strip, to the lower end of which an angle Bracket 27 is bolted. A Rod and Strip Connector 28 is placed on Rod 25, between one of the Cranks and the Angle Bracket that supports the Rod.

Two Angle Brackets 29 are fixed to the Curved Strip 26, in the positions indicated in Figs. 1 and 2.

### The Clock Face, Weight and Pendulum

The clock face consists of 12 3" Strips bolted to a ring of white cardboard as shown in Fig. 1, with Fishplates held by the bolts used to connect the Strips together. The face is bolted to  $\frac{1}{2}$ " Reversed Angle Brackets fixed to the Strip 7 and to the  $3\frac{1}{2}$ " Strip between the lower ends of the Girders 1.

The weight consists of two Boilers bolted together to form a long cylinder. A Boiler End is attached to one end of this, and the cylinder should be filled with suitable ballast to form a weight of between  $4\frac{1}{2}$ " and 5 lbs. A Boiler End, to which a Double Bracket is bolted, is fitted over the upper end of the cylinder and is held in place by a  $2\frac{1}{2}$ " Rod and two Collars. A small Loaded Hook is placed on a  $\frac{3}{4}$ " Bolt held in the Double Bracket by lock-nuts, and is connected to a long length of Sprocket Chain. The Chain is passed round the  $1\frac{1}{2}$ " Sprocket 16.

The pendulum consists of two  $11\frac{1}{2}$ " Rods and a  $3\frac{1}{2}$ " Rod joined by Rod Connectors. It is passed through the Angle Bracket 27 and is inserted in the Rod and Strip Connector 28. The bob weight is formed by a Boiler End and a Wheel Flange held together by a 1" Screwed Rod. A nut is placed at one end of the Screwed Rod, which then is passed through the Boiler End, the Wheel Flange and a  $\frac{3}{4}$ " Washer and screwed into a Collar. The Collar is placed on the lower end of the pendulum and is fixed in position by its grub screw.

### Adjusting the Mechanism

The positions of the Angle Brackets 29 must be adjusted so that

as the Curved Strip 26 is rocked by the swing of the pendulum, the Angle Brackets allow the escapement wheel 23 to rotate one tooth at a time. One Angle Bracket should just clear the teeth of the wheel when the other is fully engaged between two teeth. This adjustment is very critical, and it may be necessary to experiment for a while in order to find the best setting for the Angle Brackets. Once this setting is obtained and a smooth, even escapement movement results, the bolts holding the Angle Brackets should be tightened firmly to prevent the Angle Brackets slipping.

The timekeeping of the clock can be adjusted by altering the position of the bob weight on the pendulum. Raising the weight will speed up the mechanism if the clock is losing time, but if it is gaining the weight should be lowered.

PARTS REQUIRED

1 of No. 1a	1 of No. 22	1 of No. 90a
1 " " 1b	2 " " 24a	2 " " 94
4 " " 2	1 " " 25	1 " " 95
13 " " 3	4 " " 26	1 " " 95a
14 " " 4	1 " " 26c	1 " " 101
2 " " 6	1 " " 27	1 " " 102
2 " " 8a	4 " " 27a	1 " " 111
4 " " 8b	1 " " 27d	1 " " 111a
3 " " 9b	1 " " 27c	4 " " 111c
12 " " 10	87 " " 37a	3 " " 125
1 " " 11	79 " " 37b	1 " " 137
5 " " 12	20 " " 38	1 " " 148
2 " " 13	1 " " 38d	1 " " 155
1 " " 15b	1 " " 57c	2 " " 162
1 " " 16	8 " " 59	1 " " 212
3 " " 16a	2 " " 62	2 " " 213
1 " " 16b	1 " " 62b	1 " " 214
4 " " 17	1 " " 82	