

# MOBILE CRANE

Designed by Dr. Keith Cameron, from the contents of Meccano Set 5, plus a Power Pack.

THIS model follows the main outline and structure of the Jones KL66. Two power units are incorporated, making possible remote-control lifting of the load and luffing of the jib. Photographs of the prototype were featured in the Meccano Magazine, November 1954.

## CHASSIS (figs. 3 & 4).

Two 4½" Angle Girders 1 are connected via their round hole flanges as follows: at their forward ends by a 2½" Flat Girder 2, its row of elongated holes projecting in front of the 4½" Girders 1; at the third hole from the front, by a 1½" x ½" Double Angle Strip 3, and behind this by a 2½" x 1½" Flanged Plate 4, flanges facing upward. A 3" Pulley is attached by 1½" Angle Girders to the chassis, Washers being used so that the Bolt shanks do not project beyond the Nuts on the upper surface of the 3" Pulley which is mounted boss down.

A pair of 2½" Flat Girders 5 bolted to the rear five slotted holes of the 4½" Angle Girders 1 are connected by 2" Strips 6 to the lugs of the 1½" x ½" Double Angle Strip 3, and provide the journals for a 4" Axle Rod carrying the rear pair of Road Wheels, with securing Spring Clips and Washers. The forward pair of Road Wheels rotate around 1½" Bolts lock-nutted in the centre holes of ½" x ½" Double Brackets 7, the Bolts also securing Corner Angle Brackets as shown.

The Double Brackets 7 are free to rotate on 1½" Bolts lock-nutted in the end slotted holes of the 2½" Flat Girder 2, and their turning is coupled by a 2½" Strip 8 lock-nutted by its end holes to the free lugs of the Corner Angle Brackets. A 2½" x 1½" Plastic Flexible Plate edged by two 3" Formed Slotted Strips completes the front of the chassis. A 2" Axle Rod is inserted in the boss of the 3" Pulley and fixed.

## BODY (figs. 5-9)

Two 5½" Angle Girders 9 are connected

front and rear by two 3½" Angle Girders, all slotted holes directed upward. A 3½" x 2½" Flanged Plate 10 is placed, flanges upward, between the 5½" Angle Girders 9, two holes from their rear ends. A 3" Pulley is secured, boss up, to the centre hole of the forward 3½" Angle Girder 9a, and to the centre forward hole of the Flanged Plate 10 behind, this last (½") Bolt also securing a 11053 'Crane' motor in place. Two Washers on the shank of this fixing Bolt space the 3" Pulley from the Flanged Plate 10. Two 5½" Strips 11 bolted at their lower ends to a 1½" x ½" Double Angle Strip, (fig. 5, fixed to the Plate 10 are supported in a vertical position by another pair of 5½" Strips 12 connected to them and to two ½" x ½" Angle Brackets bolted to the forward 3½" Angle Girder 9a.

The vertical 5½" Strips 11 are connected via their top holes by a lock-nutted 2" Screwed Rod carrying a ½" Pulley and a Fishplate, both loose on the Screwed Rod and retained in position by further lock-nuts. The forward 3½" Angle Girder 9a also has fixed to the forward face of its flange the following: a 2½" Flat Girder 13, a composite Flat Plate consisting of two overlapped 1½" x 1½" Flat Plates, and two 1" x ½" Angle Brackets 14. Two Semi-Circular Plates are fixed to the sloping pair of 5½" Strips 12, the right hand Semi-Circular Plate, (as viewed from the rear) being fixed by ½" Bolts each with four Washers on the shank for spacing purposes.

A 2½" x 1½" Plastic Flexible Plate 15 is secured by the Bolt fixing the lower end of the right hand 5½" Strip 12. A 2" Axle Rod journalled in the Semi-Circular Plates carries a 1½" Pulley and a Bush Wheel with their bosses to the right, and spacing Washers.

This is the drum for hoisting the load and it is driven by the 11053 motor already in place by a 6" Driving Band passed around the motor out-

put shaft and the 1½" Pulley. The drum for luffing the jib is on a 2½" Axle Rod 16 journalled in the fifth holes from the bottom of the vertical 5½" Strips 11, (figs. 6 & 7). The Axle Rod 16 carries between the Strips 11 a ¾" Washer and two ¾" Washers, spaced ½" apart and retained in that position by a small piece of cellophane tape, and a Collar.

On the outside face of the right hand Strip 11 the Rod 16 carries a 57t Gear. A Channel Bearing 17 lock-nutted to the third hole from the top of the left hand Strip 11 has a 1½" Pulley between its two sections, mounted loosely on a lock-nutted ¾" Bolt with its boss facing up.

## BODY SIDES (figs. 1, 2, 10).

These are each composed of a 5½" x 2½" Plastic Flexible Plate edged below by 5½" Strips and in front by 2½" Narrow Strips. Regular 2½" Strips edge the rear of these Plates, and the top edge is overlaid in each case by a compound 5½" Narrow Strip formed by overlapping 4½" and 1½" lengths.

The sides are connected at their rear edges by two 3½" x ½" Double Angle Strips 18, one being placed lugs upward, (fig. 7), and fixed to the rear centre holes of the side Plastic Plates which are in turn fixed by their lower edges to the slotted hole flanges of Angle Girders 9. A second 11053 'Crane' motor, (from the Power Pack), is bolted to the centre of the lower 3½" x ½" Double Angle Strip 18. A Double Bent Strip is bolted to the forward base holes of this second motor and fixed below to the 3½" x 2½" Flanged Plate 10 by a ½" lock-nutted Bolt.

The upper 3½" x ½" Double Angle Strip 18 can now be bolted in place at the rear of the top of the sideplates, and a 3½" x 2½" Flexible Plate is attached to it forming the rear of the body together with a 3½" Flat Girder overlaying its lower edge. Four stacked 2½" Stepped Curved Strips 19 are bolted to the underside of the rear 3½" Angle Girder to act as a counterweight, (fig. 9). A 2½" x 1½" Plastic Flexible Plate 17a is held between the top 3½" x ½" Double Angle Strip 18 and the rear Flexible Plate, the fixing Bolts bearing slightly on the second 11053 motor to ensure good meshing between a 19t Pinion on its output shaft and the 57t Gear already mentioned. The upper structure will be added later.

## THE JIB (figs. 1, 2, 7 & 9).

A pair of 12½" Angle Girders are connected below via their end slotted holes by a 2½" Strip, and above at their next to end holes by a Fishplate. A pair of 9½" Angle Girders lengthened by 7½" Strips overlapping their round holes by nine holes, (but fastened at the eighth hole) are fixed below by their second holes to the 12½" Angle Girders thus allowing a one-hole projection, (fig. 7).

At the upper end of the jib, the 12½" Angle Girders and 7½" Strips are joined by two 1½" Flat Girders 20 to which Flat Trunnions are bolted. 1" Corner Brackets are also secured as shown and a 2½" Axle Rod journalled in their free holes carries ½" Pulleys and Collars. A 2" Rod in the apex holes of the Flat Trunnions carries two 1" Pulleys, (rims together), one fixed and one loose, with Washers for spacing purposes. The pulley block consists of a Fishplate and a 1½" Narrow Strip bolted to a Loaded Hook with a ½" Pulley on a ½" Bolt lock-nutted in place.

FIG. 1: The Mobile Crane fully described by Dr. Cameron.

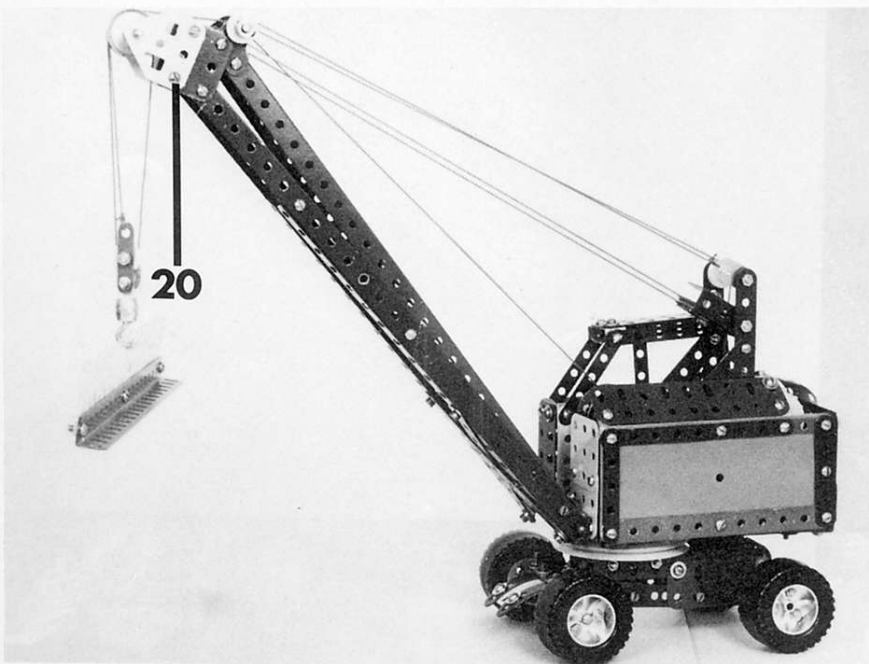

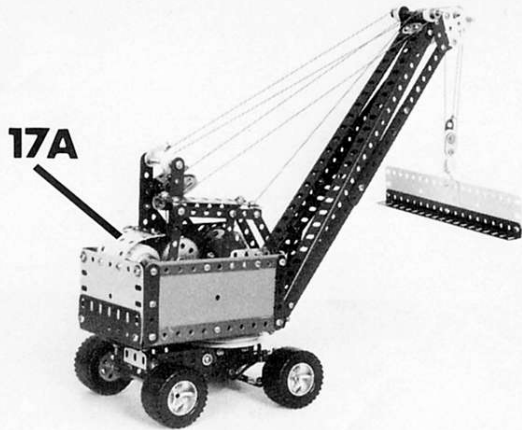

FIG. 2: Rear 3/4 view showing arrangement of cords and cab detail.

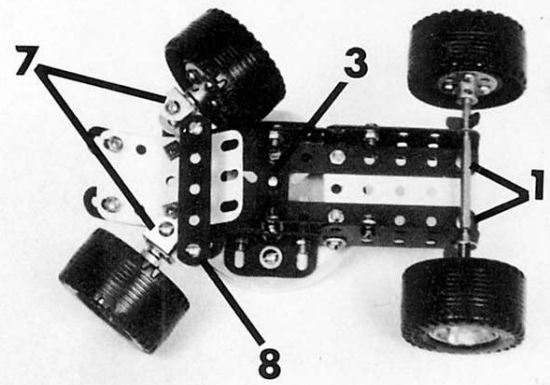

FIG. 3: The chassis as seen from below.

**THE CORDS (figs. 1, 2 & 10).**

The jib pivots on a 3 1/2" Axle Rod passed through the projecting holes of the 9 1/2" Angle Girders and the lugs of the 1" x 1/2" Angle Brackets 14, and held in place by Spring Clips. A length of Cord fastened to the Fishplate at the top of the mast is passed forward, around and then under the left-hand 1/2" Pulley at the top of the jib, back and around the 1 1/2" Pulley within the Channel Bearing 17, then forward again, around and then over the right-hand 1/2" Pulley at the top of the jib, back and then over the 1/2" Pulley on the mast 2" Screwed Rod. Finally it is passed down from here to be secured with plastic tape to the rear winding drum.

Friction provided by the motor will be sufficient to prevent the jib from falling except when the motor is actuated. Check out the operation of the jib luffing at this point and leave wires connected to the motor. A length of Cord fastened to the load hoisting drum passes up the jib, over the 2" Axle Rod at its summit, over a 1" Pulley, around the 1/2" Pulley of the pulley block, back up and around the other 1" Pulley, then down again to be fastened to the 1 1/2" Narrow Strip.

Again there will be enough friction to provide braking of the load except when the motor is actuated. Check this function and again leave the wires connected to the motor. Mount the body on the chassis by passing the 2" Axle Rod fixed in the chassis 3" Pulley through the Pulley of the body. Run the motor wires out through a convenient hole in the bodywork base.

**CAB AND SUPERSTRUCTURE (figs. 1 & 2).**

The cab roof consists of a 3 1/2" Flat Girder edged with two 3 1/2" Narrow Strips held by 1/2" x 1/2" Angle Brackets. It is supported in front by two sloping 2 1/2" Narrow Strips attached by 1/2" x 1/2" Angle Brackets to the top of the vertical forward 2 1/2" Flat Girder 13, and toward the rear the inner, (left) 3 1/2" Narrow Strip is held

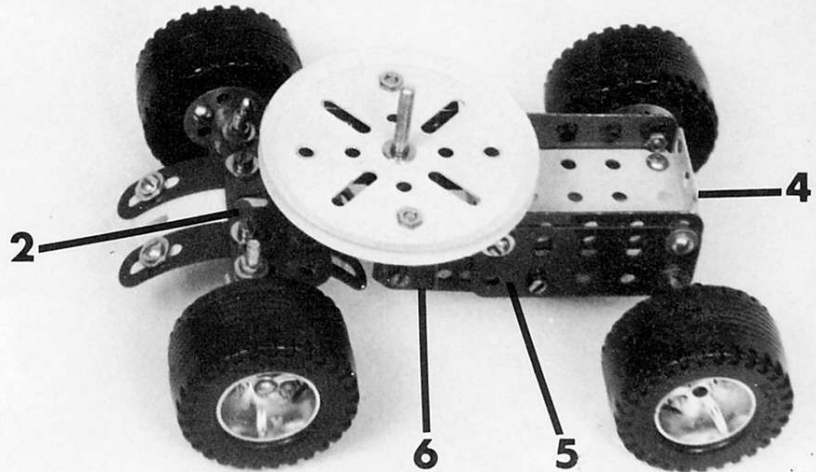

FIG. 4: Top view of the Mobile Crane chassis.

by being pinched between the junction of the two right hand 5 1/2" Strips 11 & 12. Two vertical 3" Narrow Strips are added to represent window frames. On the left side of the body a 4 1/2" Flat Girder is fastened above the side by 1/2" Obtuse Angle Brackets. The 2 1/2" x 1 1/2" Plastic Flexible Plate 17a already fixed to the rear has a 1 1/2" Narrow Strip and a 1/2" Obtuse Angle Bracket bolted to its free end, and the

Bracket is bolted to the rear hole of the 4 1/2" Flat Girder thus completing the Mobile Crane.

**ADDITIONAL NOTE**

An alternative construction for the jib is to use four 12 1/2" Angle Girders instead of the method described. This is purely a matter of taste. If parts are available, the counterweight should be made heavier.

FIG. 5: Interior of body as seen from the left, showing supports of both motors.

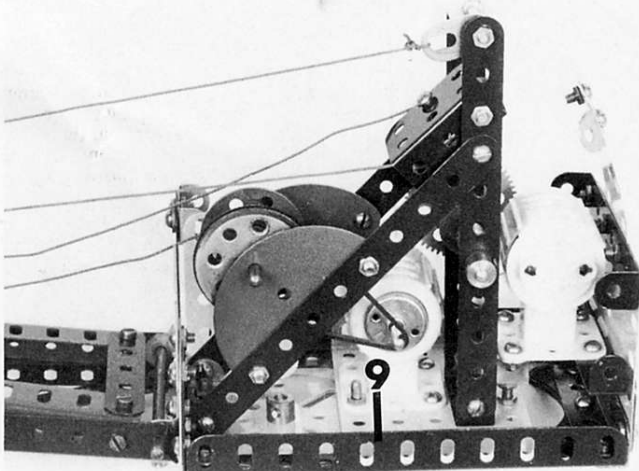
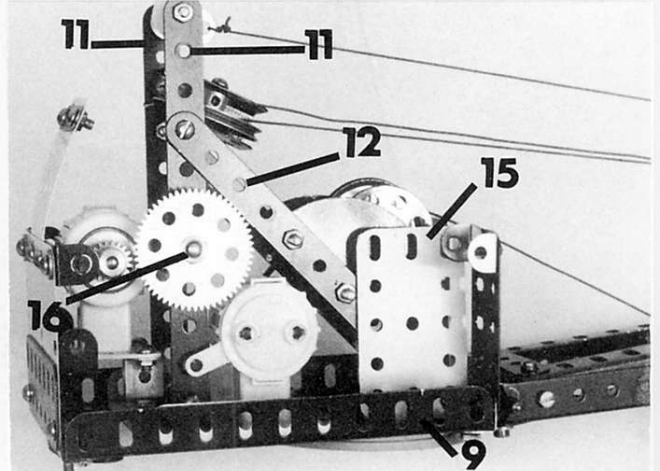

FIG. 6: View of body interior, from the right. Note gears do not mesh until back plate is secured to sides.





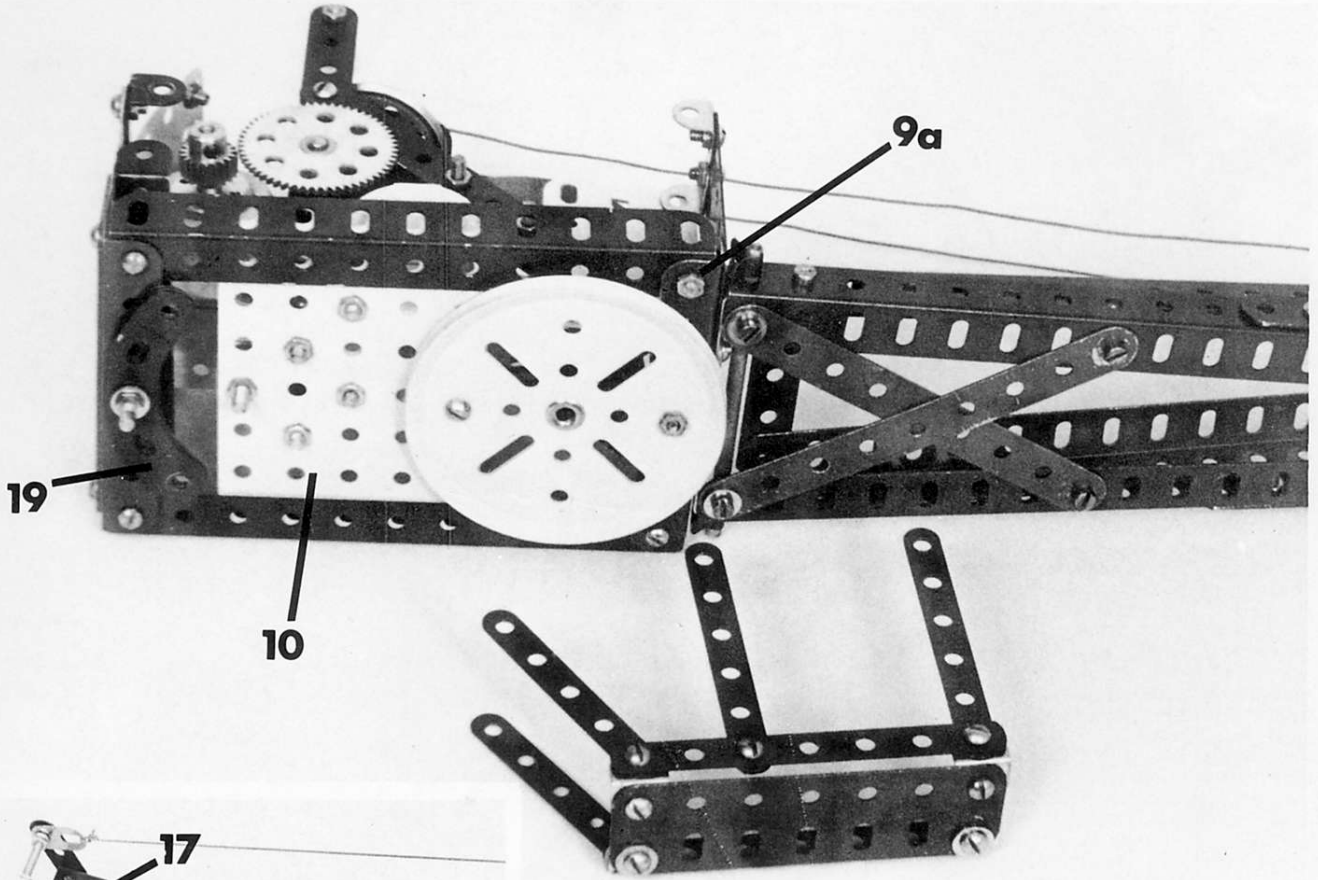

FIG. 9: Underside view of cab body showing cab superstructure detached.

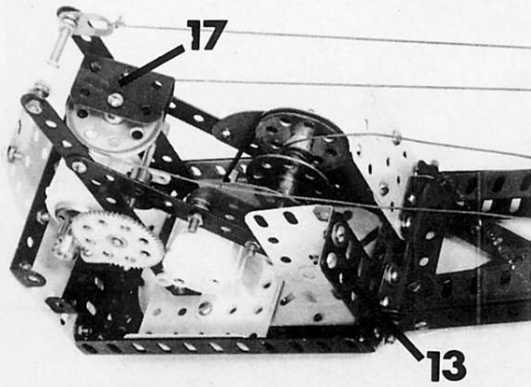

FIG. 8: Body from above, right, front, showing method of fixing the RH Semi Circular Plate.

**PARTS REQUIRED**

2 of No. 1B	8 of No. 12	1 of No. 27A	16 of No. 111A
6 of No. 2	2 of No. 12B	4 of No. 35	4 of No. 111D
2 of No. 2A	3 of No. 12C	130 of No. 37B	2 of No. 126A
4 of No. 5	1 of No. 15B	146 of No. 37C	2 of No. 133A
2 of No. 6	1 of No. 16	50 of No. 38	1 of No. 154A
2 of No. 8	2 of No. 16A	2 of No. 38D	1 of No. 154B
2 of No. 8A	2 of No. 17	2 of No. 40	1 of No. 160
2 of No. 9	2 of No. 19B	1 of No. 45	1 of No. 186A
2 of No. 9A	2 of No. 21	2 of No. 48	4 of No. 187C
2 of No. 9B	2 of No. 22	2 of No. 48B	1 of No. 190A
2 of No. 9F	4 of No. 23	1 of No. 51	3 of No. 194
3 of No. 10	1 of No. 24	1 of No. 53	2 of No. 194E
2 of No. 11	1 of No. 26	3 of No. 59	2 of No. 214
		2 of No. 74	2 of No. 215
		1 of No. 81	4 of No. 235
		4 of No. 90A	2 of No. 235A
		1 of No. 103C	2 of No. 235B
		2 of No. 103D	2 of No. 235D
		4 of No. 103F	4 of No. 235G
		2 of No. 103H	2 11053 Motors
		2 of No. 111	and Battery Boxes

FIG.10 The body with sides attached but superstructure removed to show interior.

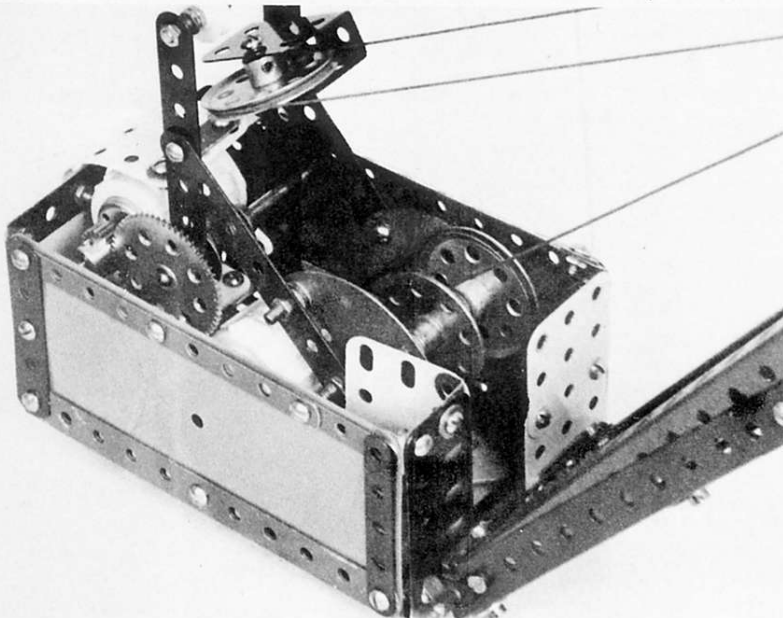

FIG. 7: The hoist drum can be clearly seen in this view from above.

