

# MECHANISMS FOR A MOTOR CHASSIS

## Concluding The Special Article By "Spanner"

LAST month, I gave details of several useful mechanisms that could be incorporated in a motor chassis. These were a steering arrangement with independent suspension, a leaf spring suspension unit, a differential, and a 3-speed and reverse gear-box, in that order. A car gear-box, however, is virtually useless without a clutch, which is a mechanism designed to disconnect the drive between the engine and the gear-box so that the gears can be changed.

### HEAVY DUTY CLUTCH

The clutch illustrated in Figure 1 is particularly unique in that it can be fitted with from two to eight Compression Springs to vary the pressure between the driving plates to suit almost any model. The heavier the model, the more Compression Springs used.

The driving member is a 1" Pulley fitted with a Rubber Ring, and it is fixed on the input shaft 1. The shaft extends beyond the Pulley, and it passes through a Wheel Disc 2 and into part of the boss of a Bush Wheel 3. The Bush Wheel is fixed on the output shaft 4.

Wheel Disc 2 is connected to Bush Wheel 3 by two Pivot Bolts. Each of these is first passed through the round hole of an Obtuse Angle Bracket 5, and through a hole in the Bush Wheel. A Compression Spring is slipped over the Pivot Bolt, which is then attached to the Wheel Disc by two nuts, one on each side of the Disc.

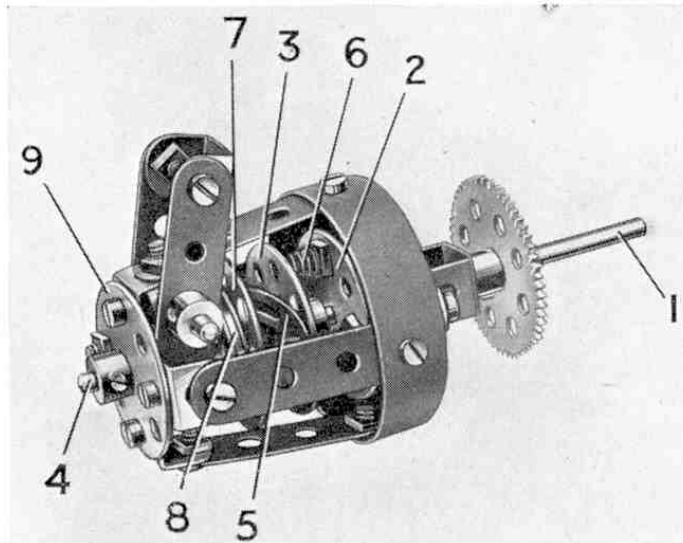

Fig. 1. A compact but very efficient clutch, which can be easily modified by fitting or removing Compression Springs, according to the weight of the model of which it is part.

The Obtuse Angle Brackets are arranged pointing in opposite directions, and they are linked by a short length of Cord that prevents them from flying outward as they rotate with the Bush Wheel. Further Compression Springs 6 can be placed between the Bush Wheel and the Wheel Disc, and they are slipped over the shanks of bolts held by nuts in the Wheel Disc.

The clutch withdrawal race consists of a Wheel Disc 7, and a 1" loose Pulley 8 separated from the Wheel Disc by a Washer.

The clutch housing is assembled from a Boiler End fitted with four 2" Strips connected by Angle Brackets to a Wheel Disc 9. The input and output shafts are prevented from sliding in the housing by a Collar on each side of the Wheel Disc 9.

Operating levers are formed from two 2" Strips pivoted as shown on a short Rod mounted in a Double Bracket fixed to the housing. The levers are linked at their outer ends by a Double Bracket and a lock-nutted  $\frac{3}{8}$ " Bolt. The inner ends of the levers bear against the face of the Pulley 8. Adjustment is obtained by sliding the Bush Wheel 3 on its shaft until the Springs are compressed slightly. When the levers are moved to the left, their action is transmitted through the withdrawal race to the Pivot Bolts, which slide to the left through the holes in the Bush Wheel and carry with them the Wheel Disc 2.

### A MODERN BRAKE

A chassis must have some effective way of being stopped and the most efficient brake in common use today is the disc brake which far surpasses the old drum brake fitted to most existing cars. An illustration of a Meccano disc brake can be seen in Figure 2, attached, as you will see, to a different form of front suspension to that described in these pages, last month.

The mechanism is mounted on a back plate provided by a six hole Bush Wheel 1. This is fitted with two Angle Brackets lock-nutted to the ends of twin transverse leaf springs that form the front suspension members. The Bush Wheel 1 forms a bearing for a  $1\frac{1}{2}$ " Rod used as a stub axle. This Rod is free to turn in the boss of the Bush Wheel and carries a Collar at its inner end.

Fig. 2. An effective disc brake built entirely of standard Meccano parts, except for a length of flexible wire used, together with Spring Cord, to make a working brake cable.

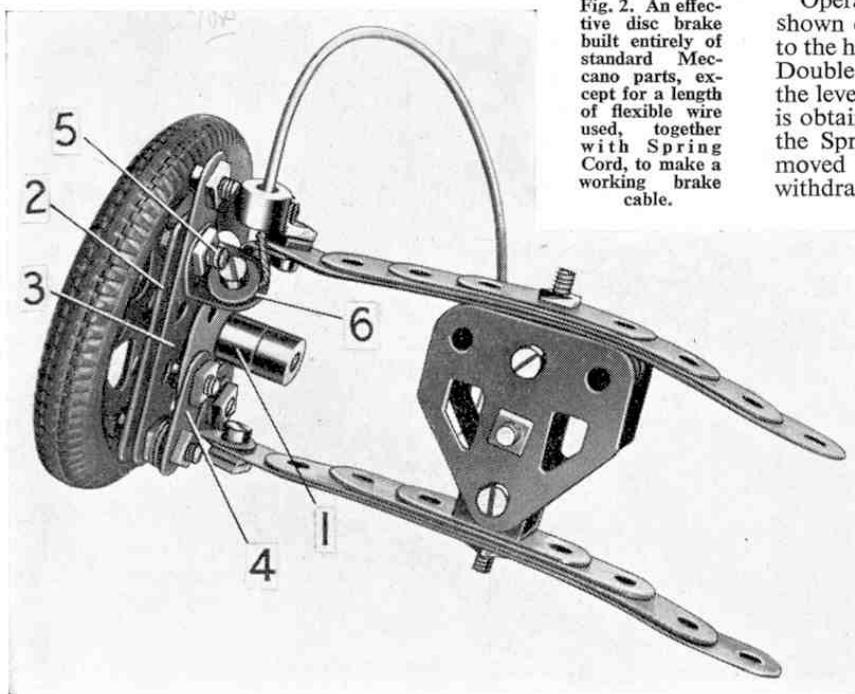

Fig. 3. This twin rear axle drive unit contains two similarly constructed differentials and includes simple leaf springing.

The brake shoes are formed by a 2" Strip 2 and a 2½" Strip 3. They are clamped together at their lower ends on a ½" Bolt, but are spaced apart by a nut placed between the two Strips. A 1" Triangular Plate 4 is bolted to the Bush Wheel 1 after which the ½" Bolt carrying Strips 2 and 3 is fitted with a nut and three Washers, then passed through the Triangular Plate and fixed tightly in place by a nut. A ⅜" Bolt 5 is passed through Strips 2 and 3, and an Angle Bracket 6 is placed on it before a nut is screwed in position. The angle of Strips 2 and 3 is adjusted until the lower face of the Angle Bracket 6 bears against the edge of Bush Wheel 1.

The brake disc is an eight hole Bush Wheel fixed on the stub axle and arranged so that it is free to turn between the Strips 2 and 3. The brake is operated by a length of flexible wire passed through a sheath formed by Spring Cord. At each end, the Spring Cord is gripped in Collars, one of which is screwed on to a ⅜" Bolt fixed by a nut on Strip 3. One end of the wire is bolted to Angle Bracket 6 and the other end is attached to a suitable brake lever. The brake is adjusted by tightening or slackening the nut on the Bolt 5.

#### A TWIN REAR AXLE DRIVE

Many heavy vehicles today are equipped with two rear axles, both of which are driven by the engine, as these give much better traction and enable heavier loads to be carried. Figure 3 on this page shows such a mechanism constructed in Meccano.

The twin axles are carried by a single leaf spring on each side of the vehicle both of which are made up of one 7½", two 5½", one 4½", two 3½" and two 2½" Strips bolted, at their centres, to a 1½" Angle Girder, which when used in an actual model can be lock-nutted to the chassis.

Each of the axle units is identical in construction. The axle casing consists of halves, formed by two 2½" × ½" Double Angle Strips bolted between a Face Plate and a Bush Wheel. The halves are joined by two 2½" × 1" Double Angle Strips, and a 4½" × 2½" Red Plastic Plate is curved to shape and bolted in position to form part of the differential casing.

The differential crown wheel is a 57-teeth Gear 1, which is free to turn on a Rod mounted in one half of the axle casing. The Rod projects into a Coupling 2, and a ⅞" Bevel Gear is fixed between the Gear 1 and the Coupling. A second Bevel 3 is fixed on a Rod that is mounted in the other half of the axle casing and also projects into the Coupling 2.

Two 1" × ½" Angle Brackets are attached by ⅜" Bolts to the Gear 1, but they are spaced from it by four Washers on each

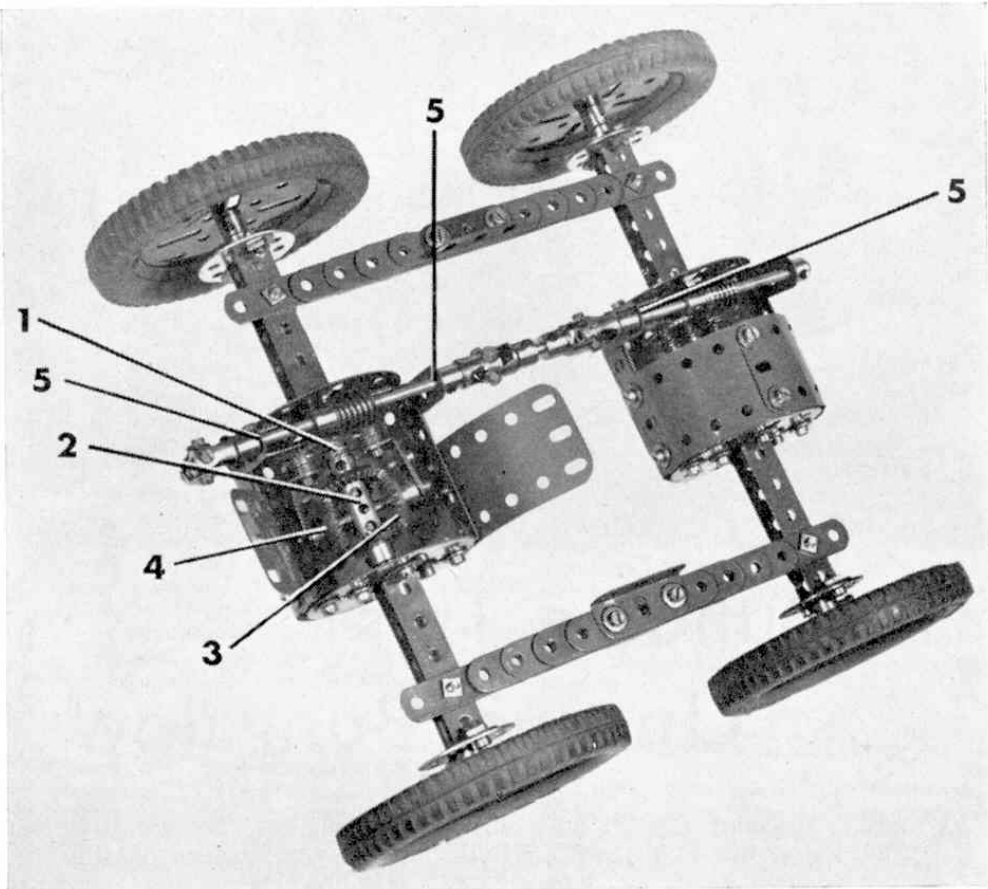

Bolt. A 2" Rod 4 is passed through the 1" × ½" Angle Brackets and is fixed in the centre transverse hole of Coupling 2. A ⅞" Bevel Gear is placed on the Rod 4 on each side of the Coupling and both these Gears are free to turn on the Rod. Fishplates are used to centre the Rod in the slotted holes of the 1" × ½" Angle Brackets.

The drive to the crown wheel is taken through a Worm fixed on a 3½" Rod that is mounted in 1½" Strips 5. These Strips are bolted to the 2½" × 1" Double Angle Strips fixed between the Face Plates. The driving rod of the trailing axle is linked to that of the leading axle by two Universal Couplings and a 1" Rod.

The differential casings are completed by 2½" × 1½" Flexible Plates curved to shape and bolted together, as shown. Note particularly that position of the Worm in relation to the crown wheel is adjusted by means of the 1½" Strips 5 which should be leaning slightly towards the centre.

\* \* \* \*

This, then, completes the series but, before finishing, I should like to point out that all the above mechanisms are taken from past issues and publications so it will probably be necessary for you to modify them slightly to suit your own specific requirements. However, you should find them most successful in operation.

#### Dinky Toy News—

(Continued from page 555)

one overhead light is available, the model should be placed so that the light falls on it at an angle of about 45 degrees. If a second light, such as a table lamp, is available it should be placed a little to one side and slightly in front of the model, and about 3 ft. away from it.

A plain background should always be provided, to avoid confusion with foliage,

brickwork, etc. outdoors, and furniture indoors. For small models a sheet of plain white or brown paper can be used, while for layouts or large groups of models, a white cloth such as a bed sheet is more convenient.

Dark shadows behind and underneath the model can be avoided by arranging sheets of white paper to reflect light on to the dark portion. Lighting conditions vary so greatly it is impossible to be

definite about the exposure time required. If one is available, an exposure meter should be used to determine the correct exposure, otherwise trial and error is the only way. Of course, time and experience will probably enable you to judge roughly what exposure to give a specific scene. When this happens, you are well on the way to being proficient in the art of photographing your miniatures.

# MECHANISMS FOR A MOTOR CHASSIS

## Useful Arrangements In Meccano

JUDGING from the correspondence we receive at Meccano—and my own experience verifies this—one of the most popular models built with our constructional Outfits is the detailed motor vehicle chassis. This does not mean the basic girder framework, which is comparatively easy to construct, but all the intricate working mechanisms incorporated in a chassis. Mechanisms such as gear-boxes, differentials, brakes, steering gear, etc. are the sort of things I have in mind and genuine working replicas of all of these can be produced in Meccano. Indeed, many examples have appeared in past issues of the *M.M.*, but they have

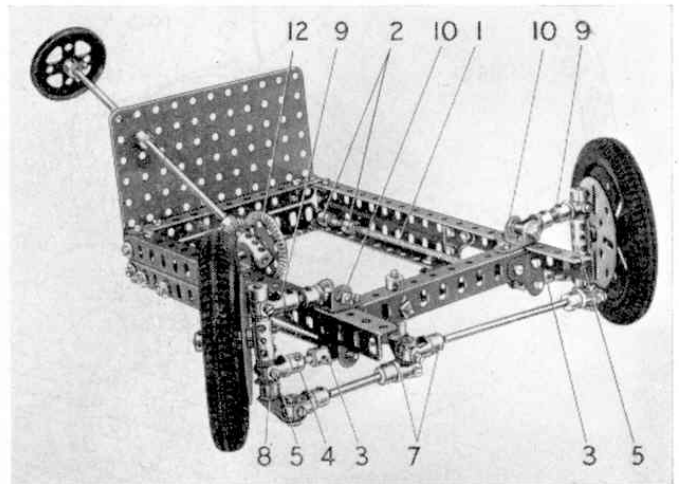

Fig. 1. An independent suspension unit, working on the torsion bar system, which includes an effective steering arrangement.

The Rod is held in position by a Collar, and the Swivel Bearing is connected by a 1" Rod and a Small Fork Piece to a Double Bracket 10. The stub axles are 1½" Rods fixed in the Coupling 5 and the links on each side are braced by radius rods 11.

Movement of the road wheels is controlled by a drop arm consisting of a Fishplate bolted to a 1½" Bevel Gear 12. The Fishplate is connected by a Rod and Collars to one arm of a Bell Crank with boss 13. The other arm is linked to the Cranks 8 by Rods and Swivel Bearings 6 and 7.

### LEAF-SPRING SUSPENSION

Many vehicles equipped with independent front suspension have ordinary leaf-spring suspension at the rear. Figure 3 gives

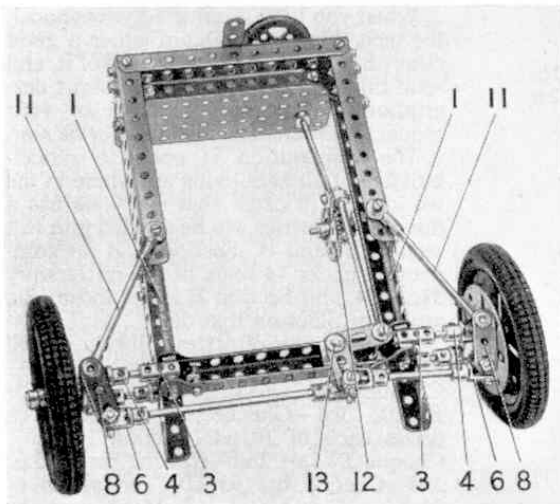

Fig. 2. The torsion bar suspension, viewed from beneath.

all been isolated cases. Here, therefore, I present a number of useful arrangements, each of which can be used in a motor chassis. Space this month will allow the inclusion of only four of the seven I wish to describe, but I will complete the set in next month's Magazine.

### STEERING AND INDEPENDENT SUSPENSION

Figures 1 and 2 on this page show a steering gear with independent or torsion bar suspension, originally designed by Mr. W. Johnstone of Liverpool. An 8" Screwed Rod 1 is fixed firmly to the chassis by two Threaded Bosses 2 which are attached to the chassis by bolts spaced by Washers. The nuts must be tight enough to prevent the Screwed Rod from turning.

The opposite end of the Screwed Rod is mounted in two 1" Corner Brackets, and carries a Coupling 3. The Coupling is also fixed on the Screwed Rod by nuts, and it carries a 1" Rod fitted with a Swivel Bearing 4. A second 1" Rod fixed in a Coupling 5 is free to turn in the "spider" of the Swivel Bearing, and is fitted with a Crank 8. The Coupling 5 carries also a further 1" Rod that is free to turn in the "spider" of a Swivel Bearing 9.

### By "SPANNER"

a useful example of the latter which, in this case, is a Semi-elliptic and Helper Spring. Construction is evident from the illustration, the Angle Bracket in the centre forming one bearing for the rear axle. The bearing can, of course, be modified to suit the rear axle being employed. It is obvious, for example, that a rear axle-casing of the type seen in Figure 4 would not make use of the Angle Bracket but would be affixed to the spring by different means.

### DIFFERENTIAL

The rear axle illustrated includes a compact but very efficient differential. Each half of the axle-casing consists of two 1½" × ½" Double Angle Strips bolted between a Wheel Disc and a Bush Wheel. A 2½" Strip 1 is bolted across each Wheel Disc and they are connected by 1½" × ½" Double Angle Strips. The left-hand

Fig. 3. This leaf spring suspension unit is composed of a basic leaf arrangement, strengthened by a small "helper" spring.

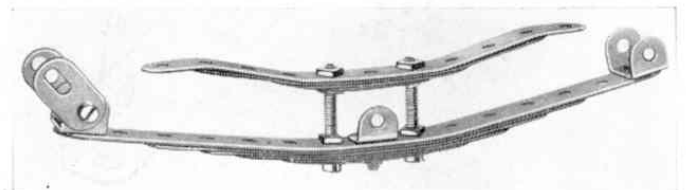



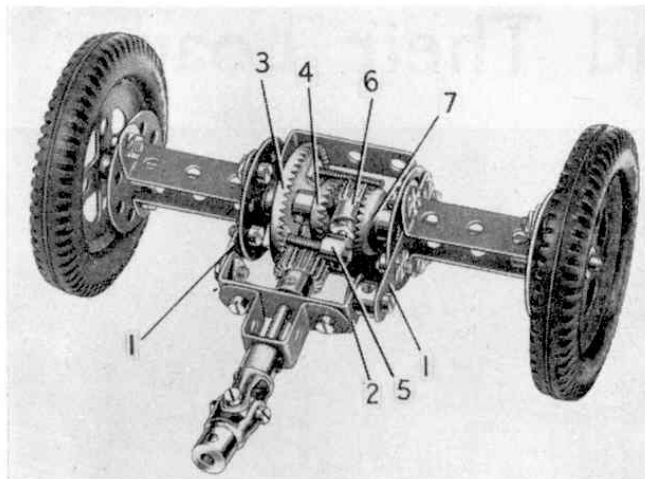

Fig. 4. A sturdy rear-axle incorporating a compact differential drive that makes use of Contrate Wheels and Pinions.

Disc is spaced from these Double Angle Strips by two Washers on each bolt. Another  $1\frac{1}{2} \times \frac{1}{2}$  Double Angle Strip 2, fitted with a Double Bent Strip, is fixed between Strips 1, but is spaced from one of them by a Collar on a  $\frac{3}{8}$  Bolt. The left-hand axle is passed through the casing and carries a  $1\frac{1}{2}$  Contrate 3 and a  $\frac{3}{8}$  Contrate 4. Two 1" Screwed Rods are held in the Contrate 3 by nuts and a Collar 5 is fixed on one of them. A Threaded Pin is screwed tightly into this Collar. The Contrate 3 is free on the axle, but Contrate 4 is fixed in place and meshes with a  $\frac{7}{16}$  diam. Pinion 6. This Pinion is loosely mounted on the Threaded Pin and is retained on it by the second Screwed Rod. A  $\frac{3}{8}$  Contrate 7 is fixed on the right-hand axle, and a  $\frac{1}{2}$  Pinion on the driving shaft is meshed with Contrate 3.

The driving shaft is mounted in the Double Angle Strip 2 and in the Double Bent Strip, and should be connected to the gear-box output shaft.

#### A FIRST-CLASS GEAR-BOX

What motor chassis would be complete without a working gear-box? The one shown in Figures 5 and 6 was designed a number of years ago by N. Gottlob of Hjortekaer, Denmark and incorporates three forward and one reverse gear. The mounting is a Face Plate 19 supporting a  $3\frac{1}{2}$  Screwed Rod 17 on which a nut is positioned about  $\frac{1}{2}$  from one end. A Washer is placed next to the nut, and the Screwed Rod is passed through one of the slotted holes in the Face Plate. Six Washers and a  $1\frac{1}{2}$  Double Angle Strip 13 are then placed on the Screwed Rod, and two Fishplates are bolted to the Double Angle Strip so that they project as little as possible beyond its ends. Two Washers are placed on the Screwed Rod, and a "spider" 25 from a Swivel Bearing serves as a nut to lock the assembly together. The centre bore of the "spider" must be exactly in line with the holes in the lugs of the Double Angle Strip. The Screwed Rod is fixed as near as possible to the centre of the Face Plate to provide bearings for the layshafts.

The bearing member of the other end of the mechanism consists of a Double Arm Crank 15, two  $1\frac{1}{2}$  Strips and two Fishplates arranged as shown. The assembly is attached by nuts to the Screwed Rod 17 and a  $3\frac{1}{2}$  Screwed Rod 18.

The input shaft is a  $2\frac{1}{2}$  Rod mounted in the boss of the Face Plate. It carries a Pinion 26 from a No. 1 Clockwork Motor, and a  $\frac{1}{2}$  Pinion arranged about  $\frac{3}{4}$  from the Face Plate. The input shaft extends only half way into the bore of the  $\frac{1}{2}$  Pinion, and the other half of the bore supports the inner end of the output shaft 4, which is a  $2\frac{1}{2}$  Rod. The output shaft carries a  $\frac{1}{2}$  Pinion placed next to the  $\frac{1}{2}$  Pinion on the input shaft, a  $\frac{3}{4}$  Pinion and two Washers.

A 4" Rod 3 carrying a Collar, a  $\frac{3}{4}$  Pinion and a  $\frac{1}{2}$  Pinion are arranged as shown. This Rod when moved to the left (Fig. 6) engages second gear, and when it is moved to the right, top gear is obtained. The 4" Rod 3a carries a  $\frac{3}{4}$  Pinion and a  $\frac{1}{2}$  Pinion as shown, and when it is moved to the right (Fig. 5) first gear is engaged.

A reverse  $\frac{1}{2}$  Pinion is fixed on a  $1\frac{1}{2}$  Rod 5, which is supported in two Fishplates 2 fixed between nuts on Rod 18. The angle of the Fishplates is adjusted so that the Pinion on Rod 5 can be meshed with both the  $\frac{3}{4}$  Pinion on the output shaft and the  $\frac{1}{2}$  Pinion on Rod 3a.

Rods 3 and 3a are each fitted with two Collars arranged so that a nut on a Bolt 20 engages between them. Two Washers are placed between the inner Collar and the Face Plate. The Bolts 20 are fixed by nuts in Collars mounted on 1" Rods supported in the lugs of Double Angle Strip 13 and in the "spider" 25. Spring Clips are placed on the ends of the 1" Rods, and are prevented from turning by bolts fixed in the Fishplates attached to Double Angle Strip 13. The two Collars are fixed on the 1" Rods by ordinary bolts and the "spider" 25 is fitted with one of the special bolts from a Swivel Bearing. The special bolt must not grip the 1" Rods.

The gear change lever is a Rod held in a Small Fork Piece 23, which pivots on Set Screws 16 passed through a Large Fork Piece 22. The Large Fork Piece pivots on a Threaded Pin passed through a Fishplate bolted to the Face Plate.

This, then concludes the first four mechanisms. Next month I will give details of a heavy duty clutch, a disc brake, and a very useful twin rear-axle drive unit, so try not to miss the January 1964 issue of the *Meccano Magazine*.

Figs. 5 and 6. Two views of an excellent 3-speed and reverse gear-box that is highly suitable for use in a motor car chassis.

