

VOL. XI. No.4

APRIL 1926

# MECCANO

## MAGAZINE

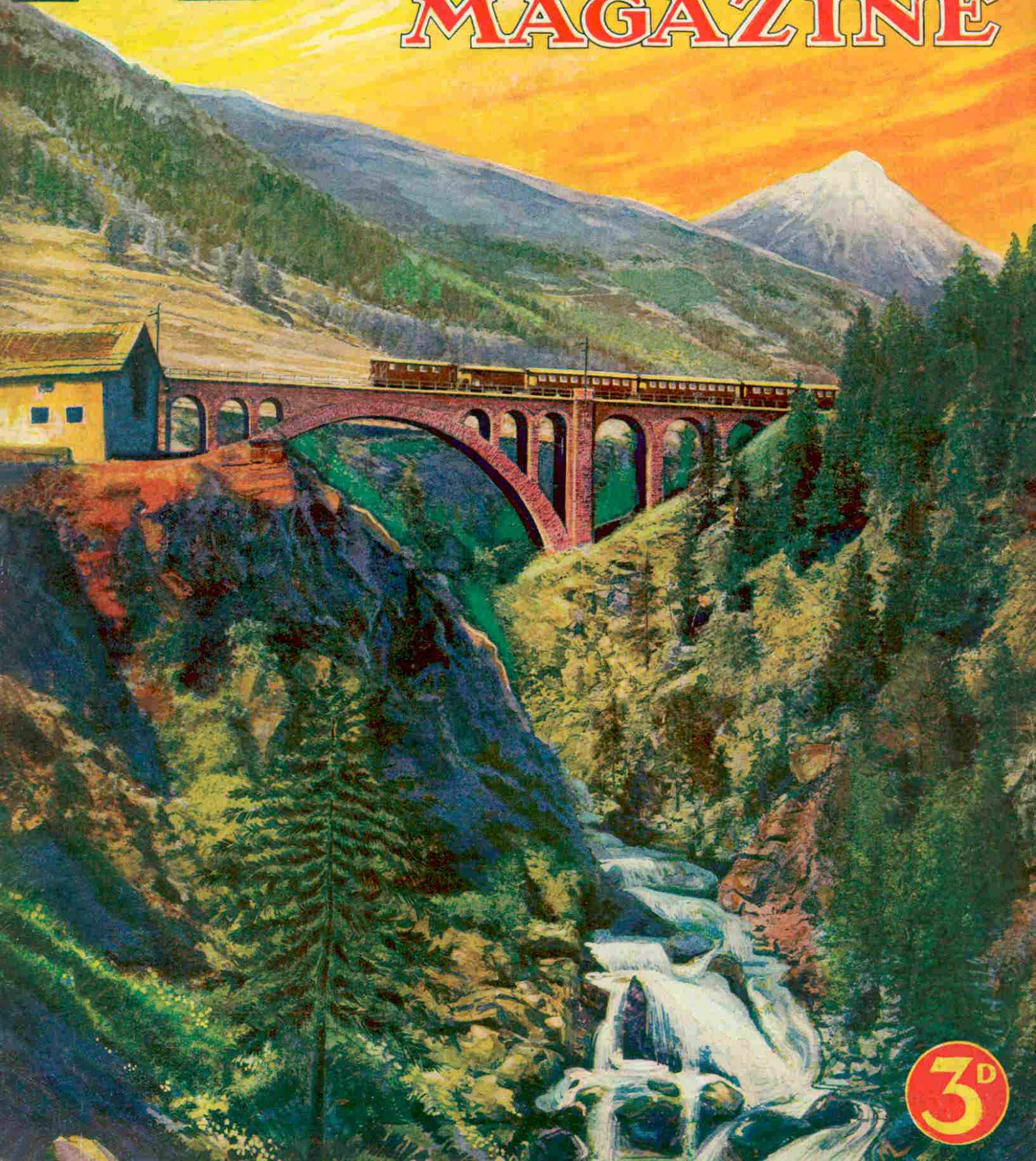

3<sup>D</sup>



*British  
right through!*

# A top-hole launch for you!



## DETAILS WHICH WILL INTEREST YOU

The hull is 30 ins. long and is finished in three bright colours of enamel. The body is streamline and the powerful engine is of oscillating type, strong and well-made of brass. A new pattern safety lamp is supplied as well as a filler for the methylated spirit and water. The twin-bladed propeller drives it at a big speed and the rudder can be set to guide the ship any direction. The boat goes under its own steam for 20 minutes at one filling. It is packed securely in a strong box, with full instructions.

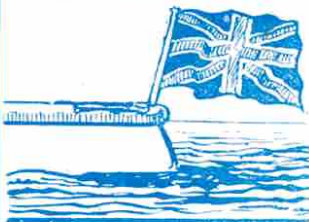

**ASK FATHER FOR ONE NOW**  
Wouldn't you be happy with this Steam Launch? It is a beautiful model 30 ins. long which will run under its own power on any lake or calm river. Thousands of delighted boys already have them, and have had hours of jolly sport.

## MISS AMERICA

Fitted with strong power unit which drives the boat at good speed through calm water for 20 minutes.

Complete with Lamp and full Instructions

**12'6** Postage 9d.

The model is British-made throughout, and has the name of Hobbies behind it as guarantee of excellence. Miss America equals many boats of double the price and is produced at such a low cost only by the mass production. The boat is safe and speedy, and a marvel of value. You'll have hours of pleasure with such a boat.

Call and see this fine Launch at Barkers, Gamages, Hamleys, Harrods, Whiteleys or any good Toyshops. Also obtainable from Hobbies Branches:-  
65, New Oxford St., W.C. 147, Bishopgate, E.C.  
79, Walworth Rd., S.E. 326, Argyle St., Glasgow.  
9a, High St., Birmingham. 10a, Piccadilly, Manchester. 214, West St., Sheffield. 89a, Woodhouse Lane, Leeds. 25, Bernard St. (formerly 11, Bridge St.), Southampton. 68, London Rd., Brighton.

**THIS WALLET FREE**

Every Meccano reader will be interested in this Wallet which gives full details of Miss America and particulars of other similar boats sold by Hobbies. Write to Miss America Dept., Dereham, or call at a Branch for one.

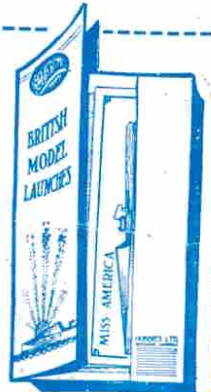

**GET ONE NOW!**

ORDER BY POST DIRECT.

FOREIGN POSTAGE EXTRA.

**HOBBIES LTD. ( Miss America Department ) DEREHAM, NORFOLK**  
and at 45, Colborne Street, Toronto, Ontario.

EDITORIAL OFFICE

Binns Road,

LIVERPOOL

Vol. XI. No. 4.

# MECCANO

## MAGAZINE

PUBLISHED

IN THE INTERESTS

OF BOYS

April 1926

## With the Editor

### The Race between Big Guns and Armour Plate

There has always been great rivalry, and an unending race, between certain nations in methods of attack and defence, and great efforts have been put forward at times to gain the upper hand in the conflict between the rival camps. Take, for instance, torpedoes, originally invented to move under water and so to hit a warship below its belt of armour. Torpedoes had not long been in existence before they were countered by the torpedo-net, hung out on booms from the side of the ship. These nets kept torpedoes at arm's-length and prevented them detonating against the side of the ship. For a time, therefore, the destructive properties of the torpedo were countered, but not for long. Inventors soon brought out a new contrivance fitted in the nose of the torpedo, which cut through the meshes of the protective torpedo-net, allowing the torpedo once again to reach its destination. Thus it became very necessary that warships should be well protected, both above and below the water line, by heavy armour plate.

There has always been keen competition, too, between the makers of armour-plate and the makers of guns. As soon as a gun was evolved that could pierce existing armour, the steel manufacturers set to work to produce an armour that would resist the new projectile. This led to larger and larger guns being forged, and, in turn, to thicker or more effective armour-plate, and consequently larger ships had to be built to carry all this increased weight.

It was felt very desirable that someone should call a halt in this costly business of building huge ships and mounting increasingly heavy guns and after a great deal of spade work by diplomats a Naval Conference was called at Washington. Here the five great powers, Britain, America, Japan, France, and Italy—whose interest in naval matters is greater than that of any other nations—agreed on a limitation of armaments. They could not agree to limit the number of cruisers to be constructed, but they did agree that the size of all cruisers should be limited to 10,000 tons, and that no cruiser should mount guns of a calibre greater than 8 in.

### Curious Result of Trying to do Good

After this agreement had been arrived at everyone concerned began to build 10,000-ton cruisers with 8 in. guns. Britain is now building 16 of these new cruisers and, incidentally, 48 cruisers, fitted with 6 in. guns are to be scrapped as "out-of-date." In order to be in line with other nations, these new cruisers must be able to steam at least 32 knots. To attain this high speed necessitates them being fitted with huge engines that, together with the 8 in. guns, account for a considerable proportion of the total weight allowed. In fact, engine and guns absorb so much of the 10,000-ton limit that there is scarcely any margin left for the usual protective armour-plating. A naval expert has said that at the most these new cruisers will have a patch of 3 in. armour-plate on the water-line. He declares that it might as well be cardboard for all the protection it offers against the 250 lb. shells fired by 8 in. guns.

Although the new cruisers will move more quickly, fire heavier projectiles and shoot further than their predecessors, it is unlikely that any one of them could remain afloat for any length of time after it had been hit. Although each of these cruisers costs over two-and-a-half millions to build and £240,000 a year to keep up, it is of more importance that they each carry 550 officers and men, and to say the least of it, it is a queer result of the Washington Conference that instead of doing good, the deliberations have resulted in planning new cruisers that are veritable death-traps for their crews, who are doomed to certain destruction the moment their ship is hit by a torpedo.

### "Do it Now"

The other day I was reminded by a few verses (see page 266) that when I was a small boy my father used to often tell me that "Procrastination is the thief of time." In those early days I used to wonder why this peculiarly-named individual should always be stealing clocks and watches! (Perhaps I associated him in my mind with another person, "Bill Stickers," whom I always regarded as a very much disliked individual, for on almost every hoarding I noticed the announcement that "Bill Stickers will be prosecuted!") However, later on I learned that my father's saying about procrastination could very well be translated into "Never put off until to-morrow what you can do to-day," and that this is a very good maxim to keep in mind is well illustrated by an incident in the story of the invention of the telephone, the centenary of which was celebrated a few days ago.

When one considers how long the world had been waiting for the invention of a telephone, it is a remarkable fact that within an hour of Graham Bell filing his specification for his patent, another inventor, Elisha Gray, also applied for a patent for a telephone on somewhat similar lines to Bell's. The coincidence did not end there, however, and it is even more remarkable that both patents were applied for at the same office! Neither of the inventors had the slightest idea that the other was engaged on similar research work. Had Bell put off, as he easily might have done, the filing of his patent for even a few hours, he would have lost a fortune, for the Bell telephone has been described as being the most valuable patent ever issued.

Whilst congratulating Bell, we cannot but sympathise with Gray, whose disappointment must have been very acute. There were subsequently hundreds of actions in the Courts over this patent, but Bell triumphed every time. Had he delayed the applying for a patent until the next day, there is no doubt that Gray would have reaped the reward that was Bell's. Although it may never fall to the lot of any of my readers to miss a fortune by such a narrow margin, they may be earnestly recommended, nevertheless, to act at once in everything they do, and not to put off their work until to-morrow, for as another proverb says:—"To-morrow never comes."

### The Lazy Boys of To-day

I see that a firm of engineers at Ilford (Essex) has been complaining that it cannot get enough boys to fill the vacant positions in their works. It seems that there are plenty of boys of a kind, but this firm's experience is that the boy of to-day is "lazy, ignorant, dirty and stupid."

"Many lads who have been sent to us," the firm states, "slouch up with both hands in their trousers pockets and lounge wearily against the door-post. They conduct an interview with the foreman with the inevitable 'fag-end' in the corner of the mouth. Some are exceedingly dirty, others appear to be mentally deficient. Quite a good percentage obviously do not want work, and when not engaged, go away feeling quite relieved. One lad questioned as to the number of sixteenths in an inch, replied that he did not know, but on further consideration he thought there were fourteen!"

I am sure that no Meccano boys have yet applied for a job with this particular firm whose indictment, I am certain, cannot be applied to any reader of the "M.M." Their remarks show, however, that there is always an opening for a bright intelligent boy. In these days of trade depression and unemployment, when everyone should be trying his hardest to "get on" either at school or at work, it is a matter for regret that it should be possible for any firm to find boys who are not eager to work and who do not want to "make good."

# The Rhaetian Railway

An Electric Mountain Railway with 81 Tunnels and 407 Bridges

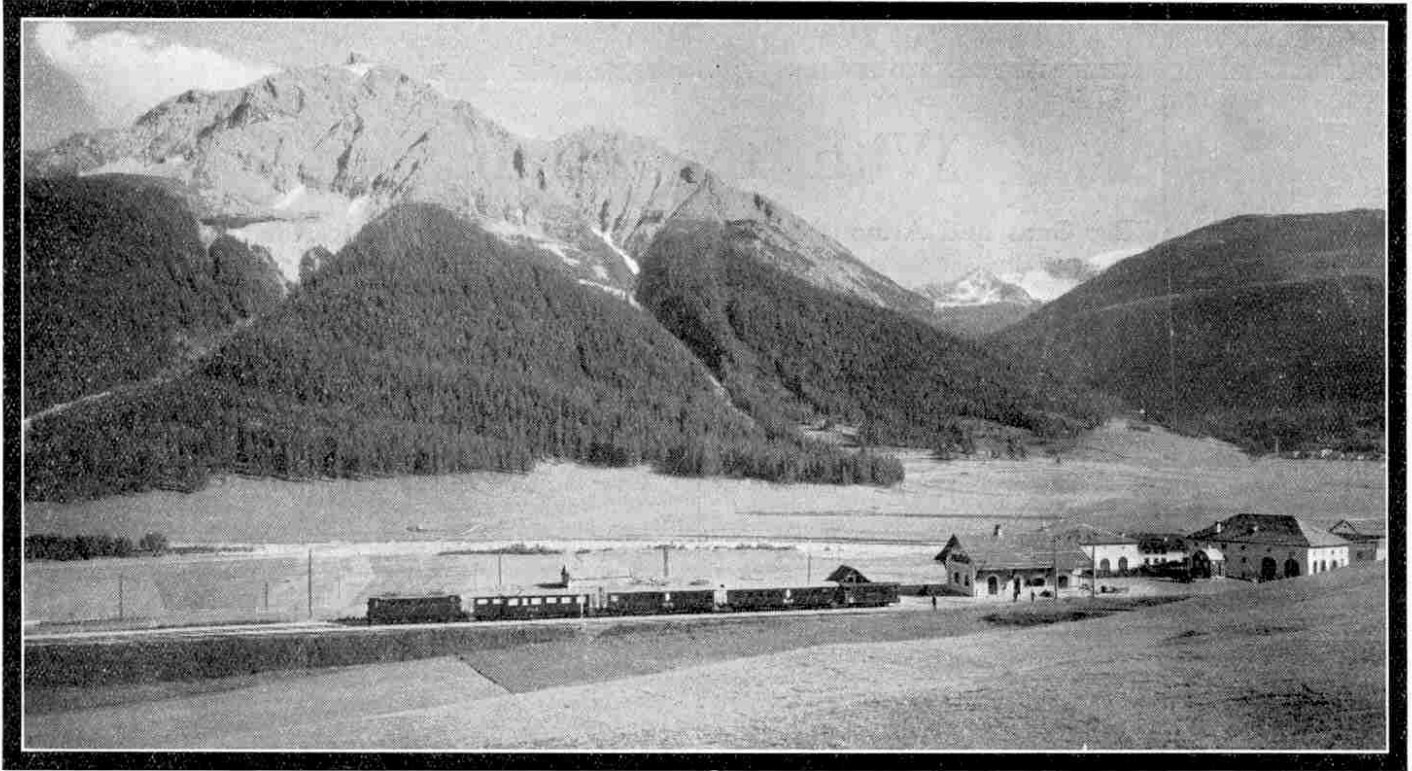

A Typical View on the Rhaetian Railway. The station at Madulein

OUR cover this month depicts a scene on the Rhaetian Railway in Switzerland, and shows an electric train on one of the many fine bridges over which this railway runs. The line is laid through some of the most beautiful scenery in the world, and the construction of the track may be claimed as a triumph of engineering skill, so that the railway is extremely interesting from more than one point of view.

Owing to the mountainous character of the country, the railway crosses a great number of steep valleys and wild gorges. This necessitated the construction of innumerable bridges, which had often to be built in the most difficult engineering circumstances. Often, too, huge masses of rock had to be cut away to form steps or ledges in mountain sides, on which the track could be laid. Altogether the planning and actual work of construction called for great technical ability and considerable perseverance and determination.

## A Railway with a World-wide Reputation

The Rhaetian Railway is well known to most travellers in Switzerland, and as large numbers of people visit this charming country every year from all parts of the world, the railway probably enjoys a world-wide reputation, and, is perhaps, known even further afield than many of its "big brothers."

Although Switzerland is one of the smallest countries in Europe and has a total number of inhabitants less

than the population of London, the traffic on the Rhaetian Railway and on the Swiss railways in general is very considerable on account of the large numbers of visitors. The railway runs through what is perhaps the most interesting part of Switzerland, the south-east region known as the Canton of the Grisons. This is decidedly an alpine canton for even its lowest valleys, where chestnuts ripen and where the vine and maize thrive excellently, are protected by high mountains.

The little alpine republic enjoys a particular all-the-year-round popularity, chiefly owing to its famous natural attractions. In the heat of summer it offers the cool mountain air of the Alps, and during the winter when fogs are prevalent in our large cities it offers the visitor the clear warm sunshine of its valleys. It is no matter for wonder, therefore, that with these attractions, and with a delightfully pure atmosphere, the Grisons is a favourite resort for sportsmen and invalids alike.

## The Maze of Valleys

Nearly half the total area of the Grisons (2,775 square miles) consists of mountains, glaciers, and alpine lakes. There is also a complicated system of mountain rivers and torrents and, in fact, almost every natural feature that makes railway construction particularly difficult.

There is a regular maze of over 150 valleys, and a tourist on foot could easily become lost in the mountains without a guide. Consequently, travelling by road is

very difficult and even dangerous, especially during the winter when it is almost impossible for a guide to find his bearings when all the notable landmarks are covered with snow. The difficulty of winter travel was entirely overcome by the introduction of the mountain railways, however, which have linked up the valleys, and made the Alps more easily accessible to visitors at all seasons. To keep the line clear in winter is a strenuous task, as the snow is often piled on both sides of the line as high as the top of the carriage windows.

Conrad Mayer, a famous Swiss poet, has written (in "Jurg Jenatsch") of the bewildering multitude of these valleys. A minister who, when explaining the mountainous character of the country to the French Duke Rohan, gives the Duke, with a few bold strokes, a sketch of the geographical features. He reduces the confusion of the valleys to an ordered scheme by arranging them according to the rivers to which they belong, all of which rise in the country and flow into three different seas. He then speaks of the numerous mountain passes and dwells with evident interest and surprising knowledge of detail upon their military importance.

**The Coming of the Romans**

The canton of the Grisons has many historic associations, dating back to prehistoric times. In those days, it was inhabited by the Rhaetians, an uncultivated and warlike people of Celtic origin, who lived in the almost inaccessible mountains. Later, it was one of the regions that the Romans decided to possess, more particularly because of the important alpine passes that formed the shortest routes from the Lake of Como to Lake Constance.

Thus it came about that the country was conquered during the reign of Augustus and in the year 15 B.C. became a Roman province. Here the Romans, famous for their engineering accomplishments, built roads across the Alps, and established fortified camps, some of which are to-day traceable in ruins.

It is interesting to find that among the inhabitants of the Grisons many Roman customs still survive, and that even to-day the native language used in this canton was originally based on

the Latin speech of the Roman soldiers and colonists, who settled in these districts.

Unfortunately we have not space to dwell at greater length on the interesting historical aspect of the country through which the Rhaetian railway runs. Indeed, the matter has only been mentioned to show that centuries ago the inhabitants of this canton were associated with a certain amount of engineering achievement.

**Importance of Road and Railways**

The growth and maintenance of any country naturally depends upon the system and efficiency of its communications. The first thing the Romans did on landing in Britain was to construct a system of roads, for they knew the importance, especially in a hostile country,

of having good communications.

The same is true, even to a greater extent in the case of the Swiss Cantons, which until the railways were constructed, depended for their communication entirely on the alpine passes. Until the commencement of last century there were no good roads in the Grisons and traffic had to cross the Alps by means of mere tracks. During the last century, however, a system of roads approximately 750 miles in total length was constructed, and some of the roads became as well known as the more famous alpine passes.

But even good roads are not the best means of maintaining communication and this is well illustrated by the fact that 25 years ago the south-east corner of Switzerland was comparatively unknown to the average tourist owing to its inaccessibility. The nearest railway station was at Coire, from which the traveller had to travel by diligence over by the Albula Pass—a journey requiring about 13 hours, and a very tiresome and uncomfortable journey it was! Now, as a result of the construction of the railway, the journey is accomplished in comfort in about 3½ hours.

It is interesting to note that up to 1923 the only motor traffic in the Grisons consisted of official postal cars. Laws in this canton are made by popular vote and in June 1923, by 11,420 votes against 9,066, it was decided to admit private cars on certain routes.

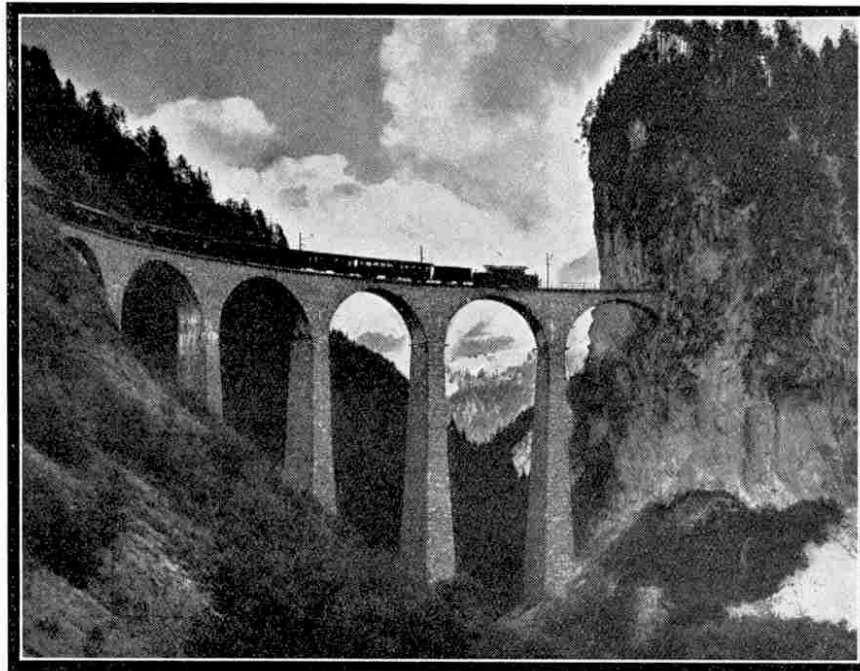

Photo] [Brown Boverie & Co.  
The Landwasser Viaduct on the Albula Branch of the Rhaetian Railway, near Filisur



Map of Rhaetian Railway

(To be continued)

# Towers of Mystery:

## Secrets of the War Revealed in "Stone Battleships"

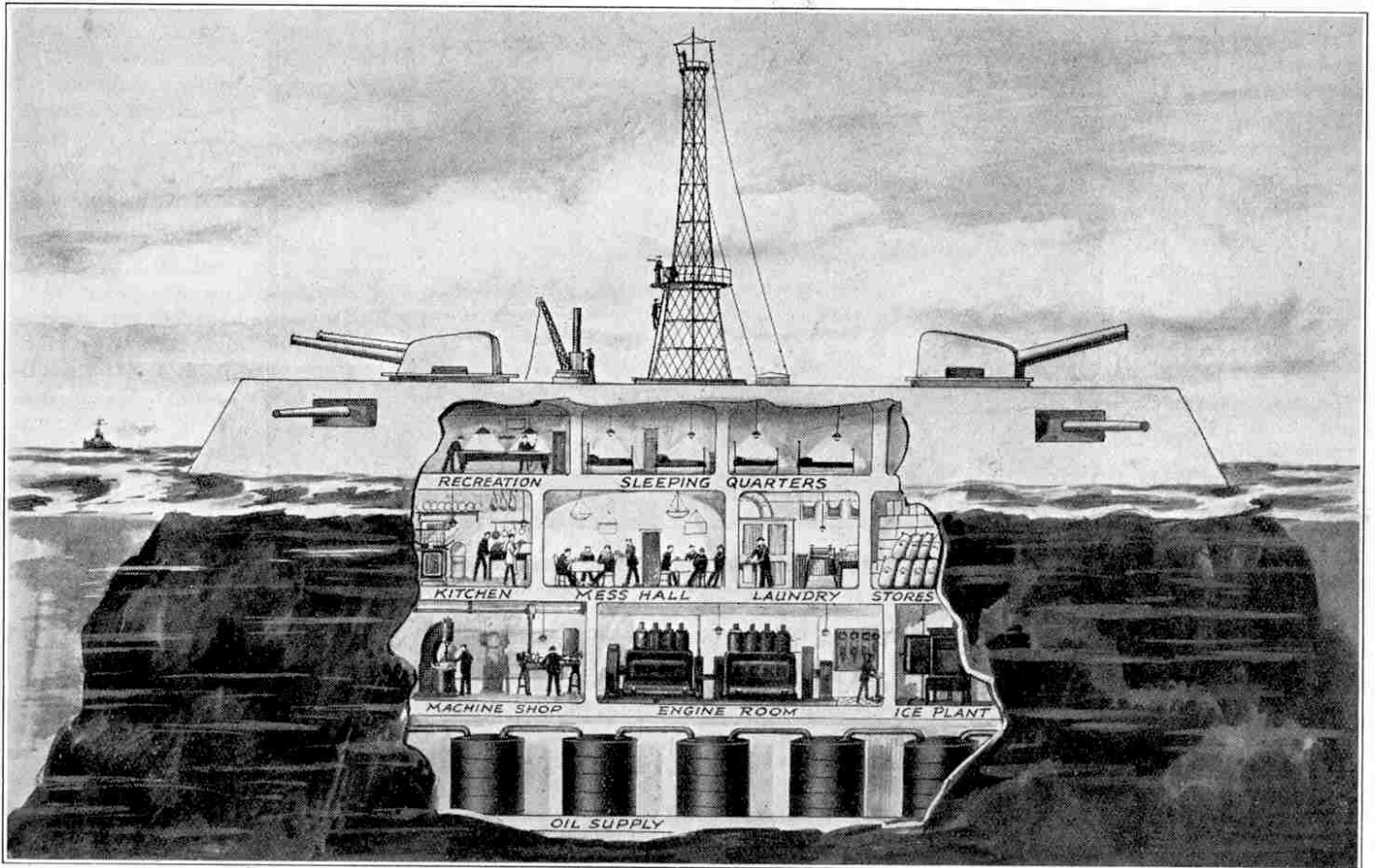

Sectional View of Concrete Fort Guarding the Entrance to Manila Bay

In a recent issue we asked our readers if they could tell us anything about the Mystery Towers that were to be erected on various parts of the south coast during the War. We have had a large number of replies and all manner of reasons have been put forward to account for the erection of these towers. Several of our correspondents had evidently drawn upon their imaginations, whilst others we suspect of making an attempt to "pull our leg!" Whatever was the purpose for which Mystery Towers were intended they certainly were not erected to "support a body of fishermen with stores of bait and rods and lines, to keep the country supplied with fresh fish during the submarine blockade." Nor were they intended as "fresh air sanatoria for wounded soldiers and sailors!"

### A Twenty-Mile Beam

Many other readers gave a more probable reason for the building of these towers, and one of the most interesting letters in this connection is that from E. Priest (of Southsea) who writes as follows:—

"As you know, during the war most of the important ports and harbours

were closed at nights, by booms and nets, in order to prevent hostile submarines from entering. The Mystery Towers were built in order to prevent submarines from passing up a channel or strait, such as the Straits of Dover, and they were really to act like large booms. Two, three, or perhaps more Towers were to have been sunk in the Straits and between them would have stretched minefields. In each tower is a room, appropriately called the "Mystery Room," in which were to be the controls for operating the minefields.

### "On Board" for a Fortnight

"One Tower, completed soon after the war, is now serving in the place of the old Nab lightship, and goes by the name of the Nab Tower. This Tower is sunk in 70 ft. of water, and the height of the lamp above high water mark is 80 ft. The lamp, which is only 18 ins. in diameter, is of 18,000 c.p. and projects a beam that can be seen for 20 miles. For as small a lamp as this, the distance quoted may seem to be exaggerated, but it is really the reflectors which actually project the beam. The lamp is electric, and is moved

by clockwork. To ensure it being always level and in a smooth running position, it revolves on a bed of mercury.

"The outer facing of the Tower is of steel plates, with lattice girders, behind this is a wall of concrete, and then more steel plates. I am not certain of the actual thickness of the walls. Under the water are the large concrete terraces, which can be seen in the photo you published in the "M.M." Stores are kept in the basement of the Tower, including food and oil and the other necessaries. Besides these are the motors for driving the dynamos for the electric supply, and also the machines used when any repairs are needed. There is, of course, a boat which is kept on the Tower. The men are out on the Tower for two weeks, and in rough weather sometimes for longer. Then they are relieved and brought ashore, where they stay for three weeks at work in the dockyard."

### 10,000 tons of Reinforced Concrete

Since the above-mentioned letters were received from our readers we have made further enquiries about the Mystery Tower Ships, as they were called. As a result

we have come to the conclusion that these great structures were undoubtedly designed for purposes of coast defence.

Their height over all was 180 ft., the diameter of the concrete base about the same, and the total weight was calculated to be some 10,000 tons. The base and the four lower decks were built of six-sided hollow concrete blocks, which in section resembled honeycomb. About 100,000 blocks were required to form the base of one Tower, the total weight of the blocks being about 9,000 tons, the other 1,000 tons being accounted for by the steel superstructure.

The Towers were designed by Mr. Menzies, a Scottish engineer, and constructed by Mr. H. A. Clift, a Canadian engineer employed by the Ministry of Munitions, who, incidentally, had previously lost an arm during the fighting in France. Each Tower was planned to have six decks, with living quarters for 100 men and accommodation for stores and machinery. The heart of the Tower was to contain a huge electrical generating plant, which was to be used for some secret purpose concerning which no information whatever is available.

Mr. R. Gammon, a Guild member living at Shoreham, has described for us a visit he had to the Tower. He says:—"The steps on the lower portion were made of wood, and appeared to be only a temporary arrangement for the workmen, who were working on the upper part. Apparently there was another stairway inside, but the public were not allowed into this part. The upper portion consisted of numerous small circular rooms one above the other. The walls were covered with coarse cork dust.

"It struck me that the rooms would be very cold and miserable. Some were extremely low pitched and it was amusing to read the numerous warnings painted on walls or girders, etc., such as 'Bob here,' 'Duck your head!' etc.

"The ascent from one room to another was made by iron ladders with narrow circular rungs. In one place you were compelled to crawl on your hands and knees from one room to another as the doorway was so small. On the occasion when I was looking over this structure, a rather stout lady became wedged in this opening. After receiving help from an attendant and some of her friends she managed to emerge into the next room but whether she ever got back again—or is still there!—I don't know."

### Fixing the Towers in Position

It was intended that a number of Tower Ships should be constructed and placed around the south coast. The idea was to tow them to the site, where they were to

only 14 ft. of water! They were easily capable of being towed into position by tugs, even though rising above the water for well over 160 ft.

The Admiralty originally intended to construct eight Towers but only two were built, and neither was actually completed when the Armistice was signed.

### Launch of the First Tower

The Towers were constructed at Shoreham, practically at the mouth of the River Adur. The launch of the first is described as being an impressive spectacle, witnessed by thousands of people despite the secrecy that had been maintained. One Sunday morning six powerful Admiralty tugs, sent down from Portsmouth, pulled with the tide and strained at their hawsers until the massive Tower began to move. Imperceptibly at

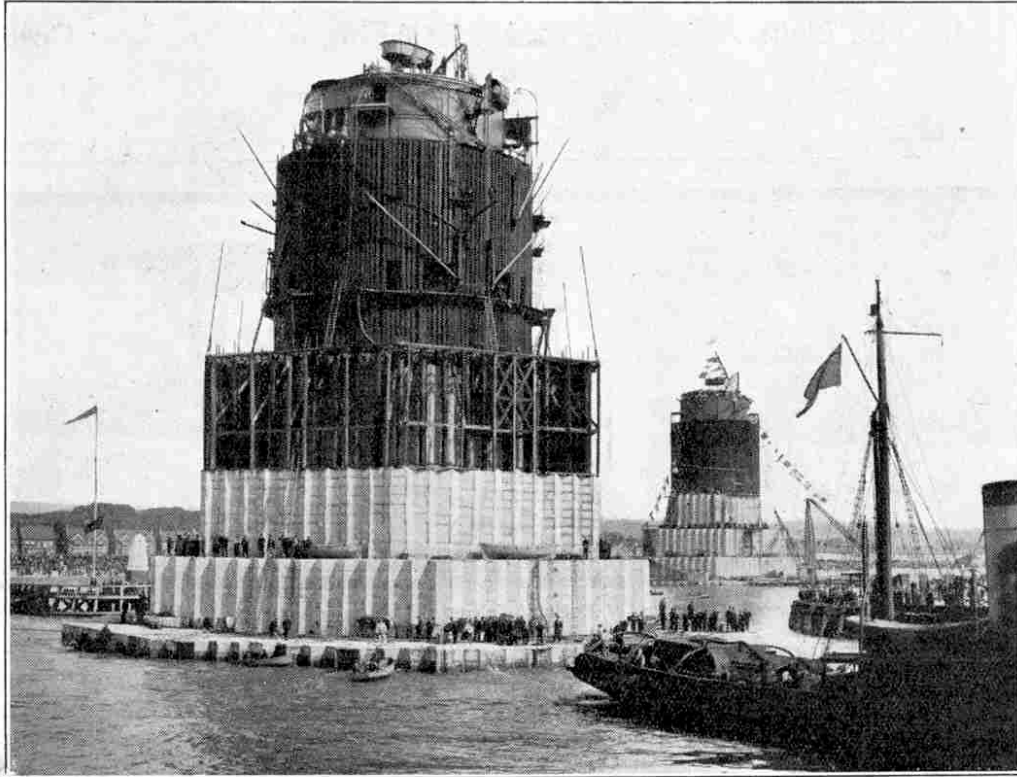

Launching the First Mystery Tower at Shoreham

be sunk some 70 ft. in the sea by filling the hollow concrete blocks in the base with liquid cement, which was to be poured through a large number of pipes connected to a temporary emergency deck. The Towers would thus be permanently established and in their final

first, but slowly and steadily gathering headway, it was towed and guided by masterly seamanship through the harbour entrance, which was cleared only by 2½ ft. on each side. Although the depth of the fairway had been increased by dredging operations, there was only a clearance of 5 ft.

Having successfully negotiated these obstacles the Tower started on its voyage of 41 miles in the open sea to its final anchorage in the Solent, between the mainland and the Isle of Wight. The voyage took 20 hours but at last the Tower was sunk in 70 ft. of water, by filling the base with liquid cement as already described. Here, on the site of the Nab Lightship, it is to-day serving the same purpose as did the lightship, and is now known as the Nab Tower.

### The "Stone-Battleship" at Manila

The idea of the Mystery Tower ships probably originated in the massive "Stone battleship" known as "El Fraile," with which the United States Navy defends the entrance to Manila Harbour.

This fortification, which is illustrated in diagrammatic form on the previous page, is built on a conveniently-placed rock between Luzon and the island of Corregidor, the rock having been hollowed out to form its base. It consists of three submarine decks, which extend to a depth of 70 ft. below the surface of the sea. On the lowest deck—equivalent to the stoke-hold on board ship—are huge oil reservoirs, while immediately above are the Diesel engines that provide the necessary electrical power for lighting and heating. Ad-

(Continued on page 246)



A Reader's Photograph of the Mystery Tower, when opened to the public

positions would rise some 110 ft. above the sea, constituting strongly fortified islands.

It seems remarkable that such ponderous craft as these 10,000-ton Mystery Towers should float, but their great buoyancy is manifest when we learn that they drew

# The Conquest of the Air

## XIII. The Light Aeroplane Clubs: Learning to Fly at Low Cost

By C. G. Grey (Editor of "The Aeroplane")



Two De Havilland "Moths" Taking Off with Passengers

WHEN I was a boy the ambition of every youngster was to become an engine-driver on a railway—there were no motor cars in those days. As the next generation grew up, every boy (and many girls) wanted to drive motor cars—and now that they are grown up most of them do it! To-day, everyone wants to fly, and most of my young friends are not content to fly as passengers but want to be pilots.

Unfortunately flying is rather an expensive game. Aeroplanes cost a great deal of money, because everything about aviation has to be so light and at the same time so strong that a vast amount of labour is used simply in cutting away weight that does not do any useful work. Every small part in an aeroplane has to work for its living. All the engine parts have to be cut down to the last fraction of an ounce, just as all the parts of the aeroplane itself have to be carved and drilled till there is not an ounce of unnecessary weight anywhere.

### Why Aeroplanes cost so much

Some idea of what this lightening process means may be gained from the Napier "Lion" engine, which is at present about the lightest engine in the world for its power. Here the original block of steel, from which one cylinder of the twelve cylinders is produced, weighs 100 lbs. when received in the factory, but only weighs 10½ lbs. when it has been completely machined ready to put into the engine! It is not only the turning into scrap metal of almost 90 lbs. of good steel that costs the money, but the amount of labour and machining

necessary to remove it that puts up the cost.

Even the "Light Aeroplanes" that have become so popular during the last few years cost a lot of money. It might be thought that, on account of their small size, these aeroplanes ought to be a good deal cheaper than they are, but as a matter of fact there is very nearly as much labour used in making all the small parts from which they are constructed as there is in making the bigger parts that do the same work in bigger aeroplanes. Therefore flying cannot become a game that

everybody can play at until the cost is reduced very considerably.

There are two ways of making anything at low cost. One is to make it in vast quantities in a big factory and the other is to make it one at a time in a very cheap way. For example, you can buy a cheap pair of boots from a factory in Northampton that makes thousands of pairs a day, or you

can buy a cheap pair from a small bootmaker who sits in his own shop and works with the simplest tools and pays a very low rent.

The earliest aeroplanes were made in the latter way, in wooden sheds built on aerodromes, and the owners of the machines worked themselves like ordinary workmen and so those aeroplanes did not cost much. During the War, 1914-18, aeroplanes were turned out in vast quantities all exactly the same, like American motor cars, and they were produced fairly cheaply. But to-day aeroplanes are built in those same great factories and so few are built that each one costs a great deal of money.



Front view of the "Moth"



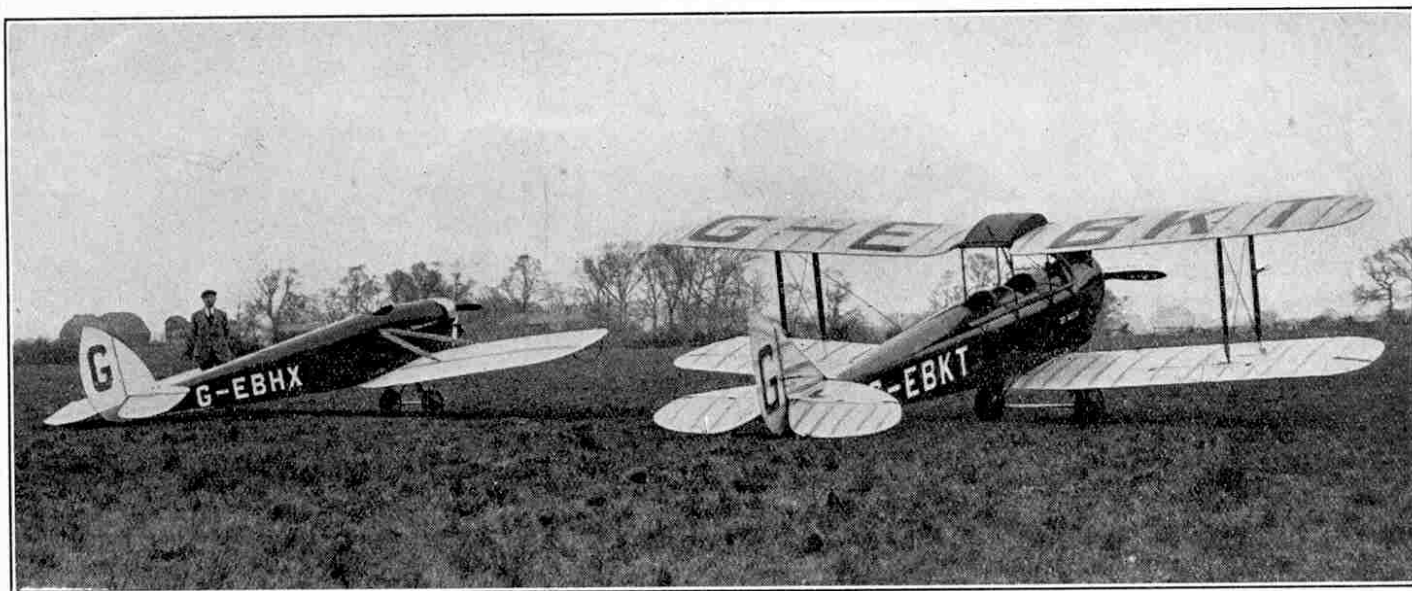

D.H. Type 53, "Humming Bird," and D.H. Type 60, "Moth"

Of all the light aeroplanes that are being flown to-day the De Havilland "Moth," with a 60 h.p. A.D.C.-Cirrus engine, is the most popular. The aeroplane is big enough and the engine is powerful enough to carry a pilot and passenger quite comfortably at about 80 miles an hour and it is really quite economical to run so far as petrol and oil are concerned. In fact it does not cost any more to run than does a motor car of medium size. But it costs £800 to buy. And there are very few young men who want to fly who can afford to spend £800 on an aeroplane and also pay for a mechanic to keep it in order and pay for its housing on an aerodrome and so forth.

#### Object of the Clubs

You see, if you keep an aeroplane on an aerodrome, you also want a motor car to take you to the aerodrome, so that really you have to spend some hundreds of pounds on a motor car as well as the £800 on the aeroplane! And when a young man has so much money as that to spend, he generally has quite a lot of other responsibilities in life, and has a social position to keep up, so that his £800 aeroplane becomes very much of a luxury.

At the same time there are many men who are really young enough to fly and can quite well afford to spend £100, £200 or perhaps £300 a year on flying for fun. And so, to give them a chance of enjoying their hobby, the Royal Aero Club, in conjunction with the Director of Civil Aviation at the Air Ministry (Air Vice Marshal Sir Sefton Brancker), organised the light aeroplane clubs that are now operating at Stag Lane, near Edgware, for the London area, and at Manchester, Leeds, Birmingham and Newcastle-upon-Tyne.

The Air Ministry bought two De Havilland "Moths" for each of these clubs and the members are endeavouring to raise in one way or another enough money to buy or build some more light aeroplanes.

#### Lancashire's Good Start

So far the Lancashire Aero Club, which operates at Manchester, has been the most fortunate. Sir Charles Wakefield, of "Castrol" oil fame, has presented a third "Moth." Sir William Letts, of A. V. Roe & Co. Ltd., has promised another light aeroplane, and the Motor Trade and the Brewing Trade of Manchester have

promised a couple more. So Lancashire is living up to its motto, "What Lancashire thinks to-day England thinks to-morrow."

These clubs, by working on the co-operative principle, have made flying a sport that is, at any rate, quite as economical as motoring. The members pay a guinea a year subscription. When they want to learn to fly they pay 30/- an hour while under instruction. That includes paying for the pilot's time while he is in the air with them, and paying for the cost of petrol and oil, insurance, and indeed everything else.

After a member has learned to fly, and has qualified for the Air Ministry's "Class A" certificate as an aviator, he can then hire the club machines at £1 an hour to fly by himself. He is entitled then to take up a passenger, if a friend cares to trust himself or herself with the newly fledged pilot.

#### Eighty Miles for £1

Thus, as the speed of the "Moth" is about 80 miles an hour, two people can travel about 80 miles for £1, which works out at 1½d. a mile each. And that is considerably cheaper than a first-class railway fare, or even hiring a car.

Apparently this very low price is only possible because the aeroplanes have been presented to the clubs in the first place. If each club had to find its £800 per aeroplane and had to reckon the interest on that money as part of the running expenses, which would be the only sound financial way of doing it, we can quite understand that the price of hiring the machines would have to be raised somewhat. But, even so, club flying, or "co-operative flying" as it is to be called, would still be cheaper than hiring motor cars or travelling by rail.

These light aeroplane clubs are becoming immensely popular each in its own district. Already they are up against the trouble that so many members want to fly that there are not enough hours in the day to accommodate them all with the aeroplanes that are available! And, of course, if one of the machines is laid up with some little engine trouble or some slight damage, even to a wheel or a tail skid, it means that there is just that much less flying time available for the members.



The "Moth" at Stag Lane, the London Aeroplane Club's Aerodrome, and its Shed

It is quite clear already that if each of the clubs had many more aeroplanes much more flying would be done, and then many more members would join, and so the whole sport of flying would increase. First of all more machines, then more flying, then more members, then more machines to accommodate the increasing number of members, and then more flying, and so on.

But the trouble is that the clubs all want more money to buy the necessary more machines. They are just in the difficult position between the man who makes boots in his own shop and the man who makes boots in a great factory, when what are called the "overhead charges" are going up and there is not yet sufficient demand to bring down the price again.

The De Havilland Company say that if they could build their "Moths" in hundreds instead of in half-dozens at a time they could bring the price down to perhaps £500 instead of £800. If they could do so no doubt each of the clubs could raise an extra £1,000 or so to buy a couple more machines. And so the amount of flying would increase enormously. Anything that will reduce the cost of aeroplanes and engines will go far towards increasing the number of members of the clubs and so will increase the amount of flying that will be done.

Apart from reducing costs simply by building in greater numbers, there are always possibilities of devising methods of construction that will either use less material or will save labour, and so will reduce costs even further. One of the cleverest of American aeroplane designers, Mr. "Bill" Stout, of the Stout Metal

Airplane Company, which is now a branch of the great Ford automobile concern, told me not long ago that he has a motto stuck up all over his design office reading:—"Simplicate and add more lightness." This is a motto that every engineer might well follow and it is particularly suitable to aircraft engineers. Some of our aeroplane builders are already realising what it means.

Not long ago one of our best known aeroplane constructors, Mr. Fred Sigris, of the Hawker Engineering Company, showed me details of the construction of the new Hawker "Heron," and you "M.M." readers will be interested to know that he described it as being: "As simple to put together as a Meccano model." The whole of the body-work, or "fuselage" as it is called, is built of square steel tubes bolted together through flat steel plates. It really is exactly like Meccano construction. Not only is this method of building cheap in itself, but if the demand for aeroplanes were enough to make it worth while to build them in what is now called "mass production" quantities, all these tube parts could be cut off in lengths and drilled and bolted together by what is practically unskilled labour.

More recently I was shown a new method of building aeroplane wings by which steel strips of a special channel section could be bolted together—also on the Meccano principle—in a way that will reduce the cost of production enormously. And still more recently I have seen yet another method of combining wood and metal construction in wings that (dare I say it to "M.M." readers?) even beats Meccano methods for quickness and simplicity, and at the same time

does not need any very elaborate machinery to make the various parts.

By these methods "simplication" seems almost to have reached its limit so far as the aeroplane itself is concerned.

The next step must be the simplification and cheap production of the engines. At the present moment we have to pay something like £200 for a reliable engine that is at the same time powerful enough and light enough to be used in an aeroplane. But it is possible to buy quite a powerful motor car engine, for about £70 or £80. And if a suitable engine for an aeroplane could be bought at that price it should be possible to sell a complete aeroplane, quite powerful enough to carry a pilot and one or two passengers, for at any rate £400 and quite possibly £300.

If we could only get down to the £300 aeroplane, not only would the various flying clubs be able to buy a lot more machines and do a lot more flying and get a lot more members, but quite a number of comparatively well-to-do people could afford to buy their own aeroplanes. Possibly these would be bought on the hire-purchase system, and kept at the club aerodromes, where they could be kept in order by the club's mechanics. Probably aeroplanes at such a price will be offered for sale within the next two or three years.

By such methods as these we shall in due course make flying quite a cheap amusement, and I believe that when you boys and girls have left school and are in business, making a living for yourselves, it will cost you no more to fly than it costs the young man or woman of to-day to run a motor bicycle.

## Back from the Cape

Mr. Alan Cobham and his colleagues of the great flight to the Cape, arrived at Croydon Aerodrome on Saturday, 13th April, on the return journey. Long before Mr. Cobham was due to arrive, hundreds of pairs of anxious eyes were scanning the horizon and each minute the crowd of watchers became greater. In addition to two huge sixteen-seater passenger planes of Imperial Airways, six D.H. Moths, one of which carried Mrs. Cobham, took the air to form part of an escort for the last few miles of the journey.

Later in the day Mr. Alan Cobham went to Buckingham Palace to deliver to the King a letter which he had brought from the Earl of Athlone, Governor-General of

South Africa. In the evening Mr. Cobham gave a short broadcast speech from 2LO in which he disposed of the suggestion that his flight was for the purpose of initiating an aeroplane service between London and Cape Town. The only practicable service would be by airship. Several excellent intermediate aeroplane routes had been found, notably that between Cairo and Central Africa, which would reduce the mail times to and from London from one month to seven days.

The journey home resolved itself into a race between the D.H.50 and the mail steamer "Windsor Castle," which left Cape Town on the same day as Mr. Cobham,

26th February. At first sight the race would appear to have been a simple task for an aeroplane travelling at 100 m.p.h., but it should be remembered that the mailboat had only 5,300 miles to travel, steaming for 24 hours per day, against 8,500 miles to be covered by the airman who, of course, had to spend the nights at different places and make a total of 26 stops.

As the "Windsor Castle" was not due to arrive home until 15th March, the D.H.50's performance was excellent. The actual flying time from the Cape to Croydon was just over eighty hours, giving an average speed of over 100 miles per hour.



# FROM OUR READERS

This page is reserved for articles from our readers. Contributions not exceeding 500 words in length are invited on any subject of general interest. These should be written neatly on one side of the paper only, and they may be accompanied by photographs

or sketches for use as illustrations. Articles that are published will be paid for at our usual rates. Statements contained in articles submitted for this page are accepted as being sent in good faith, but the Editor takes no responsibility for their accuracy.

## The Widening of Trent Bridge

The widening and improvement of the well-known Trent Bridge is now nearing completion and it may be of interest to give some account of this handsome and interesting structure.

The first bridge at this point of the river was built by Edward the Elder in 924, and except for the stone piers was constructed entirely of wood. This was superseded by one of the first stone bridges in the country, built by Henry II. in 1156. The present handsome iron structure was opened in 1871 and proved entirely satisfactory until after the war, when the enormous increase in motor traffic rendered it inadequate. The City Council realised the necessity of having the bridge widened and strengthened, and having obtained substantial assistance from the Government, commenced operations in March, 1924. From that time until the opening of the new portion of the bridge in October, 1925, four massive derricking cranes were employed continuously and the progress of the work was watched by the public with keen interest.

It was desired to preserve the old appearance of the bridge from downstream and therefore the outer decorated arch rib of the old structure was removed to the outer end of the new portion, and likewise the parapet. The old arch ribs are of cast-iron while the new ones are of mild steel. When the new portion was finished the old portion was closed and the roadway stripped. The cast iron ribs were then strengthened by filling in the space between them with reinforced concrete. In addition, the whole of the cross girders and floor decking have been replaced by a stronger structure.

A notable feature of this fine piece of engineering has been that the bridge was never closed during the operations, traffic passing all the time in both directions. If it had been necessary to close the bridge vehicles either would have had to cross the river by the toll bridge at Wilford, a mile further up and quite away from the main road, by Kelham Bridge near Newark, 20 miles down the river, or by Sawley Bridge, some 10 miles further up. Trent Bridge is one of the most important bridges in the country for it is one of the principal connecting links between north and south.

E. K. LAWRENCE (Nottingham).

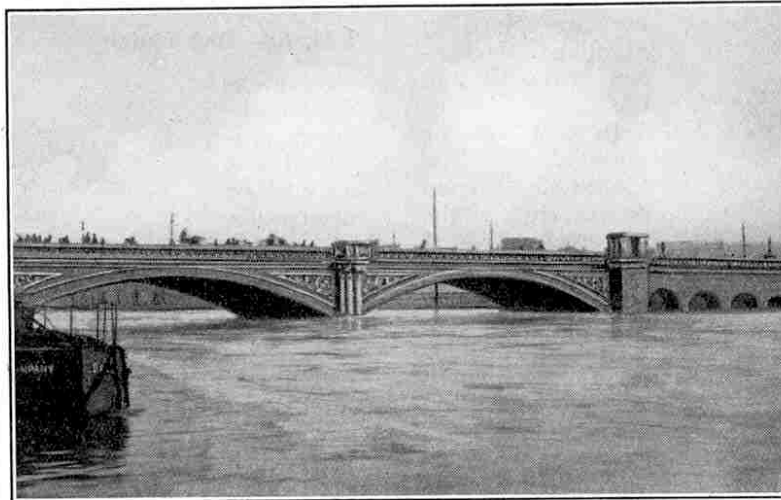

Trent Bridge as it is to-day

## A Trip on a Pilot Cutter

I have always taken a great interest in ships and it was with huge delight that I accepted an invitation to spend ten days on the pilot cutter "*W. A. Massey*," of the Humber Pilot Service. The work of this vessel consists in conveying pilots and stores of all kinds to the outer station cutter "*Commander Cawley*," which is anchored about three miles off Spurn Point.

I found myself one of a party of nine boy passengers. They were mostly sons of pilots and some of them had made the trip before. In addition there were eight apprentices, who apparently welcomed our arrival and cheerfully made light of the extra labour entailed by our presence. For the senior apprentice we shall all keep a warm corner in our hearts for a long time to come, remembering the kindly way in which he

"fathered" us, one and all. The pilots on board were all extremely good to us and took a kindly interest in all our doings. Imagine the novelty to town-bred boys of sleeping in bunks and living the lives of real "sea-dogs!"

We were fortunate in being allowed to land several times at Spurn and were greatly interested in the fort with its guns, searchlights, machine-gun pits and many other things. The soldiers stationed there found enjoyment even in our juvenile company and the games of cricket indulged in were enjoyed by all who took part. Occasionally we had a sing-song and treated them to selections from our wonderful (?) band. We climbed the lighthouse and amused ourselves in scores of ways known only to schoolboys on holiday.

Spurn itself is a very isolated place. Fresh water has to be taken there daily by a Government steamer from Grimsby, while the nearest railway station is six miles away. A splendid new motor life-boat has recently been installed.

I was the only Liverpool boy in the company, the others all coming from Hull or Grimsby, and I had my work cut out to hold my own in the lively discussions on the relative merits of our respective ports!

This, my first trip, certainly strengthened my desire to enter upon a sea-faring life, but before that time arrives I hope to join once more the happy party on the pilot cutter, next time as one who has "been before."

A. HAGUE (Liverpool).

# MECCANO STANDARD MECHANISMS

## Section V. Clutches, Reversing and Drive-Changing Mechanism

*This article is the sixth of a series explaining some new and interesting aspects of Meccano model-building practice. Gear Ratios, Belt and Rope Mechanism, Pulleys, and Levers have been dealt with already, and the following article describes some simple examples of Meccano Clutches and Drive-changing Mechanism. These movements may be adapted with advantage to numerous Meccano models, and will enhance both their appearance and efficiency in operation.*

THE Meccano Dog Clutch (Part No. 144) lends itself to a number of useful movements, and forms an excellent method by which the driving power of a model may quickly be thrown in or out of gear with the driven mechanism while it is in motion.

Examples of its use are given in Standard Mechanisms Nos. 61 and 63.

In S.M. 61 the jaws of the Dog Clutch 3, carried on the ends of the two Axle Rods 1 and 2, are brought into engagement on operation of a lever 4, which is pivotally mounted on a short Rod 5 secured in a Crank 5A.

The lever rests between two Collars 6 mounted on the shaft 1. This shaft slides in its bearings,

S.M. 61

and its movement, in addition to combining the clutch members 3, throws a Bevel Wheel 7 in or out of gear with a similar wheel 8.

### S.M. 62—Clutch

This type of clutch is shown fitted to the Meccano Chassis. The clutch is operated by means of the foot pedal 6 pivoted on the shaft 5, which on being pressed down, slides the Rod 2, to which it is connected by the Double Bracket 7 journalled between the Collar and set-screw 8 and the boss of the Bush Wheel 9.

As the Rod 2 slides in its bearings the Threaded Pins 10 bolted to the Bush Wheel 9 are thrust further into the holes of the  $1\frac{1}{2}$ " Pulley 11, and at the same time the Bevel Wheel 4 is drawn out of gear with a second Bevel Wheel 3 on the driving shaft 1. This allows the

engine to revolve freely, while the chassis remains stationary. Immediately the pressure relaxes on the pedal 6 however, the counter-shaft 2 is pushed back into its former position by the springs 12 (extracted from the Meccano Spring Buffers), and the bevel drive 3 and 4 is brought into gear again.

### S.M. 63—Dog Clutch

This standard mechanism provides another illustration of Dog Clutch mechanism. The clutch member 1, carried on a short Rod which slides in suitable bearings, is brought into engagement with the clutch jaws mounted on a further Rod 2, by means of a lever 3. The latter is pivoted

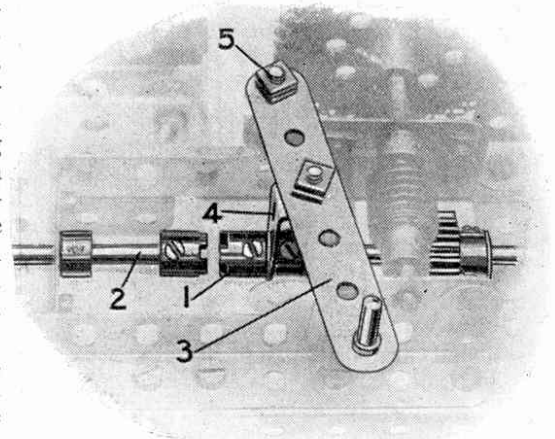

S.M. 63

engagement with the clutch jaws mounted on a further Rod 2, by means of a lever 3. The latter is pivoted (by bolt and lock-nuts) to an Angle Bracket at 5, and also to a Single Bent Strip 4 loosely held between the clutch segment 1 and a Collar and set screw.

A considerable improvement is effected by connecting a Spring to the lever 3, in such a manner that it normally holds the clutch members together. This Spring re-engages the shaft 2 immediately pressure is relaxed on the lever 3.

### S.M. 64—Drive-Changing and Reversing Gear

S.M. 64 illustrates a compact example of gear box, which provides two speeds and a reverse gear. The model serves well in demonstrating the type of gear box usually fitted to automobiles.

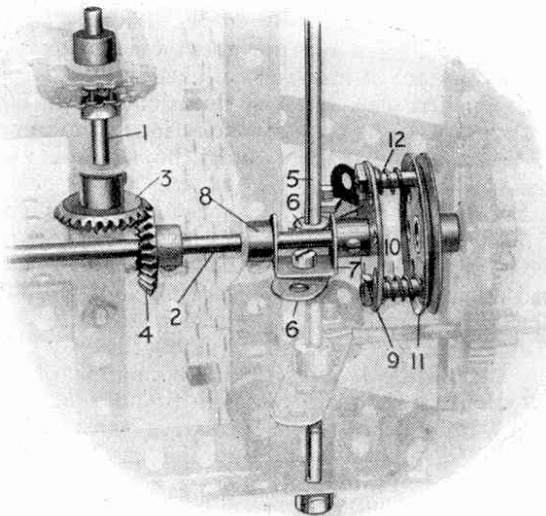

S.M. 62

The shaft 1 takes up the drive from the engine. This shaft, which is journalled through one end of the gear box and further supported by a 1"×1" Angle Bracket 2, carries a 50-teeth Gear Wheel 3 and two  $\frac{3}{4}$ " Pinions 4 and 5. A secondary shaft 6 is also inserted in the gear box and carries one  $\frac{3}{4}$ " Pinion 7, two 50-teeth Gear Wheels 8 and 9, one 1" Gear Wheel 10 and one  $\frac{1}{2}$ " Pinion 11. A further shaft 12 is next mounted in position, and its outer end carries the drive to the road wheels. The Rod 12 carries a  $\frac{1}{2}$ "

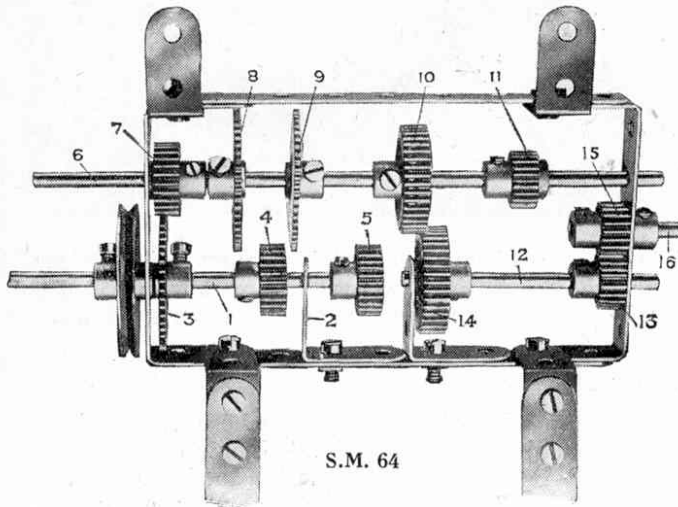

S.M. 64

Pinion 13 and a 1" Gear Wheel 14. A  $\frac{1}{2}$ " Pinion 15 secured to a 1" Rod 16 gears with the Pinion 13.

A lever should be next assembled, and serves to slide the shaft 6 in its bearings. A suitable lever for this purpose will be found in S.M. 52 (see last month's "M.M.") and on reference to this detail it will be seen that the Rod A, connected at right angles to the lever by means of a Coupling, may readily be mounted so as to lie transversely across the shaft 6, with its Collar engaging between the Gear Wheels 8 and 9. A movement of the lever will then push the Rod 6 in either direction as required.

The first position of the Rod 6 provides for a "top" speed, and in this position the Pinion 7 is in engagement with the Gear Wheel 3, Gear Wheels 10 and 14 are in engagement, while the Gears 8, 9 and 11 are all free. In this manner the Gear 3 causes the Pinion 7 on the secondary Rod 6 to revolve twice as fast as the primary Rod 1, and the propeller shaft 12 rotates at the same speed as the shaft 6, since it is driven from that shaft through the one-to-one gear 10 and 14. The Pinion 15 revolves idly in this position.

For slow speed the shaft 6 is moved along until the Pinion 7 is out of engagement with the Gear Wheel 3 and the Gear 8 meshes with the Pinion 4, while Gear Wheels 10 and 14 are still engaged. With this arrangement the driving shaft 1 will revolve twice as fast as the driven shaft 12.

A reverse gear is obtained by sliding the Rod 6 still further, until the Gear Wheel 9 is in engagement with the Pinion 5 and

the Pinions 11, 15 and 13 are all in mesh.

**S.M. 65—Drive-Changing and Reversing Gear**

A Crank 1, secured to the vertical shaft 2, carries a short Rod 3 loosely journalled in a Coupling 4 also secured to the shaft 2. The short Rod 3 protrudes slightly from the lower Collar 5 and enters a hole in the Bush Wheel 6 bolted to the Plate 7. The Rod 2 is loosely journalled through this Bush Wheel 6 and engages, by means of the Pinion and 57-teeth Gear Wheel 8 and 9, a further Rod 10. The latter carries in a Coupling 11 a short Rod 12 which engages between two Collars 13 on an intermediate driving shaft 14. This shaft 14 is thus moved to and fro in its bearings by lifting the Collar 15 and moving the Crank 1 to left or right until the Rod 3, actuated by a small spring 16 (extracted from the Meccano Spring Buffer, Part No. 120A), snaps home into the next hole of the Bush Wheel 6. The central position of the Rod 3 enables the shaft 14 to revolve freely, but the movement of the Rod to the next hole in the Bush Wheel brings the Pinion 17 into gear with another Pinion 18, whilst a move of one hole in the opposite direction brings further Pinions (not shown in the photograph) secured to shaft 14 into engagement with Gear Wheels carried on a further driven shaft (also not shown).

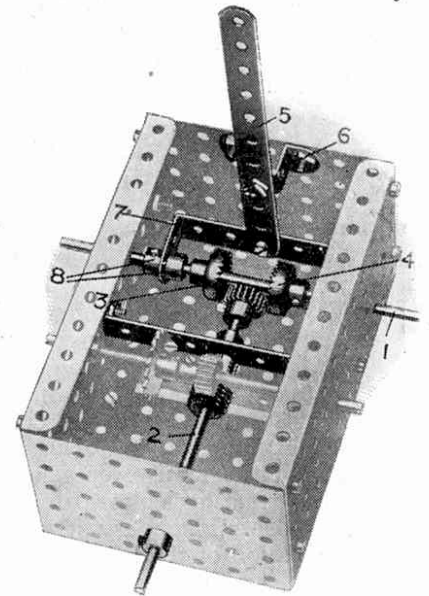

S.M. 66

Thus this movement may be utilised (a) to throw the Motor out of gear with—say—the road wheels of a tractor, (b) to drive the same forward at reduced speed, and (c) to reverse the direction of their rotation.

It should be noted that in our illustration a side plate corresponding to that shown at 19 has been removed in order to disclose the mechanism. Normally this plate is bolted to the Girders 20 and 21 and so forms a bearing for the shaft 14.

**S.M. 66—Reversing Gear**

The driving shaft 1 is caused to engage a  $\frac{1}{2}$ " Pinion on the secondary shaft 2 through one or other of the  $\frac{3}{4}$ " Contrate Wheels 3 and 4. The change is effected by a lever 5 pivoted to a Double Bent Strip 6 and carrying a  $2\frac{1}{2}$ "×1" Double Angle Strip 7, through which the driving shaft 1 is journalled. The Double Angle Strip is held in place on the Rod 1 by means of Collars and set-screws 8. The direction of rotation of the Rod 2 varies according to the Contrate Wheel which drives it.

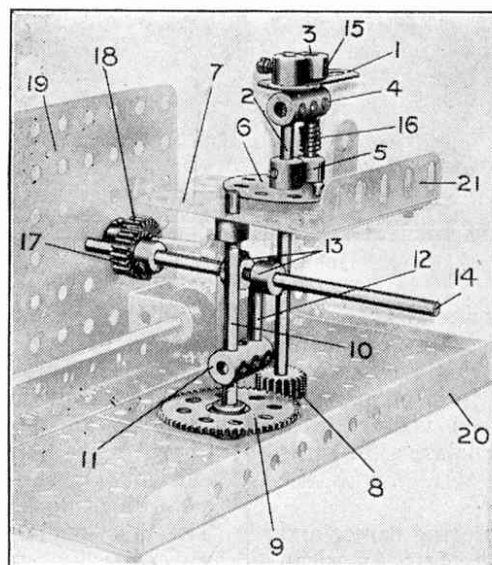

S.M. 65

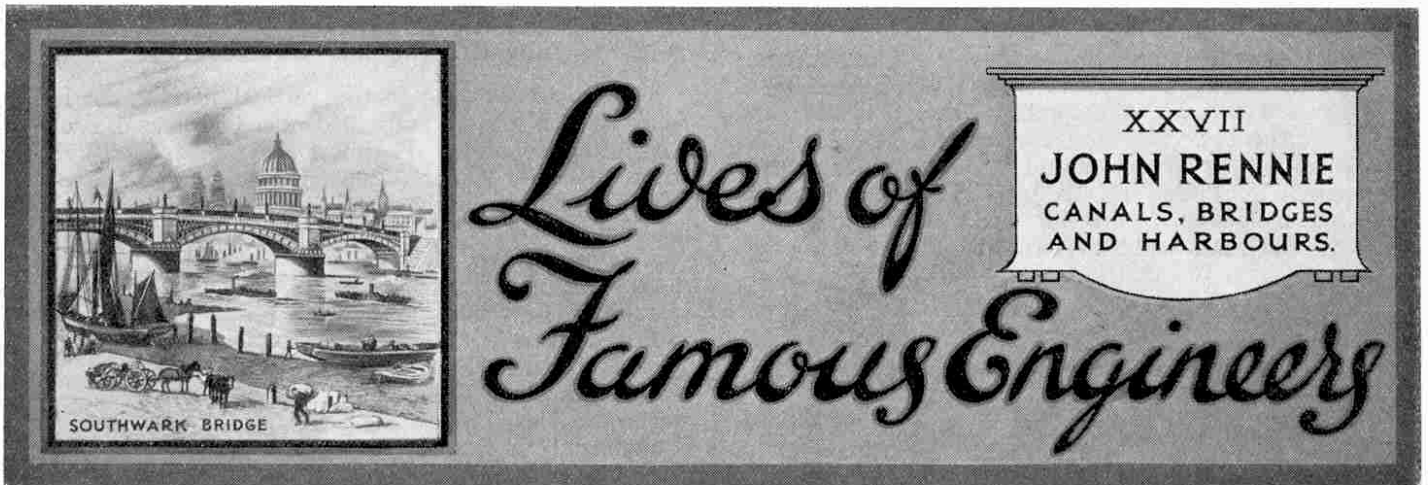

**J**OHAN RENNIE, the architect of three great London Bridges and the engineer of the Plymouth Breakwater, was born on his father's farm estate at Phantassie in East Lothian, Scotland, on 7th June 1761. This small estate was situated about half way between Haddington and Dunbar, and had been the property of the family for generations.

At that time agriculture in Scotland was in a very backward condition. Very little real cultivation of the land had been done, and clover, turnips and potatoes had not yet been introduced. No cattle were fattened, indeed even the hardy black cattle could scarcely find enough herbage to keep them alive throughout the winter. Rennie's father was considered to be one of the best farmers in the district and it is recorded that he was one of the first to introduce turnips as a regular farm crop.

#### The Rennie Family

Farmer Rennie died in 1766 leaving a family of four sons and five daughters. George, then 17 years old, was the eldest, and from that time he managed the farm and acted as the head of the family. The year before his father's death George had visited many farms in Berwickshire in order to learn the latest methods in use there, and on his return to Phantassie he introduced so many improvements that his farm became regarded as a model throughout the district. His reputation extended even beyond his own country and became so great that he was consulted on farming matters by visitors from all parts of Europe. Among his most distinguished visitors at a later period was the Grand Duke Nicholas, afterwards Emperor of Russia, who stayed several nights at the farm.

William, the second son, chose a seafaring career and was taken prisoner and died during the first American war. The third son, James, became an Army surgeon and was killed in India at the siege of Seringapatam

while dressing the wounds of his commanding officer under fire. John, with whom we are now concerned, was the youngest son and was only five years old when his father died.

#### Andrew Meikle

Like many other of the engineers whose lives we have already described in the "M.M.," Rennie displayed his mechanical inclination and ability at a very early age. When he was six years old his favourite toys were his knife, hammer, chisel and saw, and the ordinary toys that delighted his companions did not interest him in the least. His greatest joy was to visit the smith's and carpenter's shops in the neighbouring village of Linton, watching the men at work and trying the various tools for himself whenever he was allowed. His favourite resort of all, however, was the millwright's shop of Andrew Meikle, a few fields away by the side of the river Tyne.

Meikle was a particularly ingenious mechanic and he settled at Houston Mill on the Phantassie estate where he occupied himself as small farmer, miller and millwright. He himself fitted up the machinery of the mill, adjoining which was his workshop. At that time there were very few mills in the district, but Meikle's reputation

for skilled workmanship was so high that his services were in great demand for repairing or fitting up mills over a wide area.

The agricultural machinery of that day was exceedingly primitive and Meikle soon turned his attention towards improving it. In particular he sought to construct an efficient threshing machine and after some years of experimenting he succeeded in perfecting his invention. The first machine on Meikle's principle was driven by water power and proved thoroughly successful, and shortly afterwards he erected a similar machine, only driven by horses, for George Rennie at Phantassie.

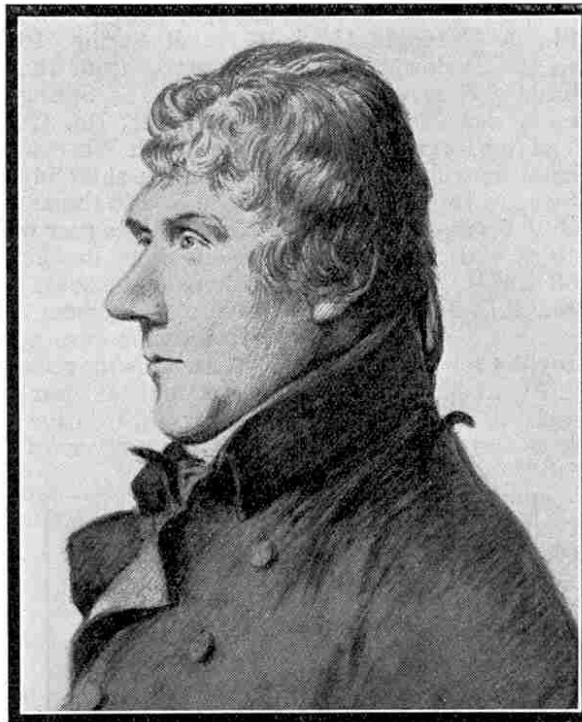

John Rennie, F.R.S.

The patent for this invention was taken out in 1788. Unfortunately for Meikle he was not a business man and he allowed unscrupulous people to deprive him to a large extent of the fruits of his invention. John Smeaton, who knew Meikle intimately, used to say that if he had possessed more 'push and go' he would have been one of the first mechanical engineers of the day.

### A Badly Scared Woman

Meikle's great ideal throughout his life was to introduce machinery in every possible situation in order to save labour, and his own household was full of mechanical contrivances. We are told that on one occasion a woman came to his mill with some barley to be ground and was asked to sit down in the cottage while the work was being done. No sooner did the mill wheels commence to turn, however, than a cradle and a churn in the cottage began to rock and revolve respectively. There was no one else in the cottage at the time, and the woman was convinced that some supernatural agency was at work and rushed away scared out of her wits. In view of such incidents as this it is not surprising that Meikle's neighbours declared that he was "no canny!"

### A Shock for the Butler

Meikle often travelled considerable distances to instal or repair pumping apparatus. On one occasion he had undertaken to supply a gentleman's house with water. It happened that various other mechanics had undertaken this task and failed, and consequently the butler had little faith in the success of the latest effort. Meikle promised that he would send in the water next day and asked the butler to have everything ready. The butler's reply was: "It will be time enough to get ready when we see the water." Meikle said nothing, but got his machinery to work very early the next morning, and when the butler got out of bed he found himself up to his knees in water!

Meikle lived to the great age of 91 and apparently was in good health almost to the last. We are told that at a family gathering less than a year before he died he played his favourite instrument, the Northumbrian bagpipes, to provide music to which his six sons and their families danced. One wonders how many men of 90 could tackle the bagpipes!

### Early Tuition

When Rennie began to go to the parish school at Prestonkirk he had to pass Meikle's shop and frequently temptation was too strong for him and he played truant. Meikle took a strong liking for the boy

and let him have the run of his workshop, besides giving him valuable advice in the use of the various tools.

In spite of occasional truancies Rennie made good progress at the parish school and by the time he was 12 years old it was thought advisable to transfer him to a better school. There appears to have been some difficulty in deciding upon his next school and in the meantime the boy occupied himself with making models of various kinds. Models did not satisfy him, however, and he became extremely anxious to tackle more serious work. He therefore set to work to persuade his mother to allow him to go to Meikle to learn to be a millwright

and finally his persuasions were successful. For two years he worked hard under Meikle's supervision at smith's work, carpenter's work and millwright's work, and acquired mechanical skill that was of great value to him in later life. At the end of two years he was sent to Dunbar High School where he quickly outstripped his school fellows, particularly in mathematics.

On leaving school finally he returned to Phantassie with the intention of commencing an engineering career.

He spent much time in the workshop of his friend Meikle, assisting him in various ways, and before long he became entrusted with the repair of mills in cases where Meikle could not undertake the work himself. At the age of 19 we find Rennie engaged in fitting some new mills near Dundee, designing both buildings and machinery and superintending their erection. Shortly afterwards he carried out with great success extensive repairs to flour mills near Edinburgh. These early successes brought him into prominence and by the time he was 20 he had as much millwright's work as he could undertake.

### Studies at Edinburgh University

Rennie had no intention of remaining a country millwright, however, and he decided to improve his knowledge by studying at the University of Edinburgh. He matriculated in December 1780 and joined the classes of Doctor Robison, Professor of Natural Philosophy, and Doctor Black, Professor of Chemistry. In addition to these studies he set himself to learn French and German and during the three years he remained at the University he worked very hard.

On leaving the University in 1783 he set out to visit the more important engineering works in England in order to widen his knowledge. He first inspected Brindley's Bridgewater Canal and the Liverpool Docks, and from there made his way to Birmingham, where he took the opportunity of visiting the firm of Boulton

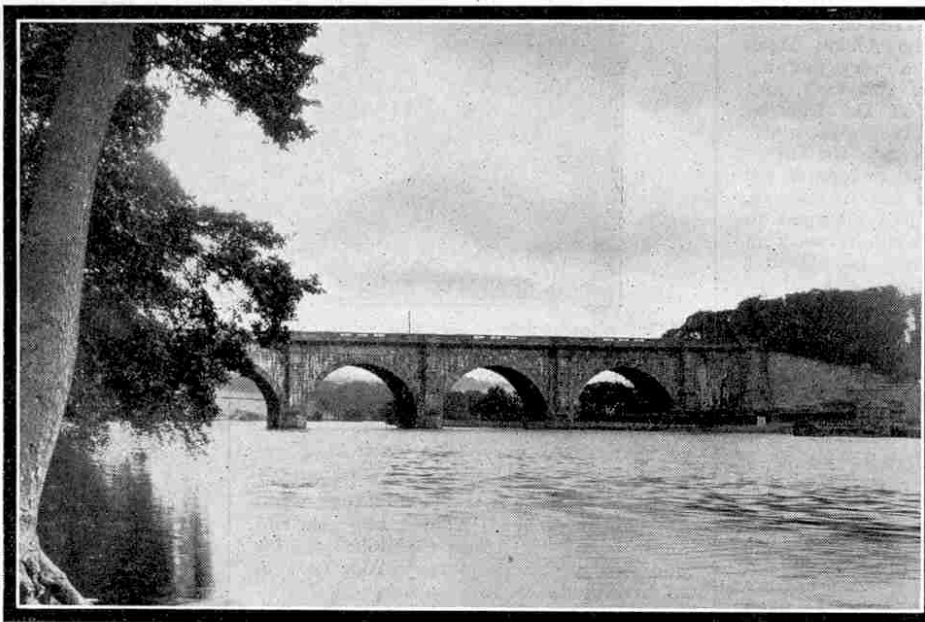

Photo]

Lancaster Aqueduct

[G. Wynspear Herbert, Lancaster.

and Watt and of presenting to the latter a letter of introduction from his late professor, Doctor Robison. Watt received his young visitor with great kindness and a friendship sprang up between them, which lasted until the death of Watt.

#### An Offer from James Watt

At that time the steam engine was beginning to be applied to driving machinery in mills and elsewhere, and when Rennie visited the Soho Works a large steam engine was under construction for the purpose of driving the machinery of a large corn mill to be erected in London. Watt knew little of millwork and was in great need of a skilled millwright to superintend the work in London at what was to be known as the Albion Mills. Rennie appeared to be a very suitable young man to undertake this task, and after Watt had consulted Dr. Robison and obtained a highly favourable reply, he invited Rennie to undertake the supervision of the proposed mills, as regards the planning and erection of the machinery.

At that time Rennie had returned to Scotland and was very hard at work in superintending the building of his first bridge across the Water of Leith, about two miles west of Edinburgh. Rennie decided to accept this offer, and after finishing the work in hand he set out in September, 1784, for Birmingham, where he remained for two months, during which he acquainted himself fully with the details of the engines by which the mill machinery was to be driven. He then went to London.

#### The Albion Mills

The Albion Mills were erected on the bank of the Thames near the south-east end of Blackfriars Bridge. The engines for driving the machinery were the most powerful that had hitherto been produced at Soho Works. They consisted of two double-acting engines each of 50 h.p. having a steam pressure of 5 lbs. to the inch. These engines drove 20 pairs of mill stones each 4 ft. 6 in. in diameter, 12 of which generally worked together, each pair grinding ten bushels of wheat per hour. The two engines working together were capable of dealing with 150 bushels an hour, an output far greater than that of any other mill of the time. In addition to its main work the engine power was applied to loading and unloading the barges, and in various other ways.

The details of the machinery were almost entirely worked out by Rennie and the task occupied him nearly four years. Everything was completed in 1788, to the great satisfaction of Watt and to the astonishment and admiration of the public. It is interesting to note that John Smeaton visited the new mills and heartily congratulated Rennie upon his success. The mills were commercially successful and appeared to have a bright future, but unfortunately they were completely destroyed by fire three years after their completion.

The Albion Mills thus disappeared, but they had lasted long enough to establish Rennie's reputation as an engineer and to obtain for him extensive employment. For a time he was employed chiefly in designing and constructing machinery for mills of various kinds, and his first civil engineering work in England was the construction of the Kennet and Avon Canal, a work upon which he spent enormous care.

## The Twins are Meccano Boys!

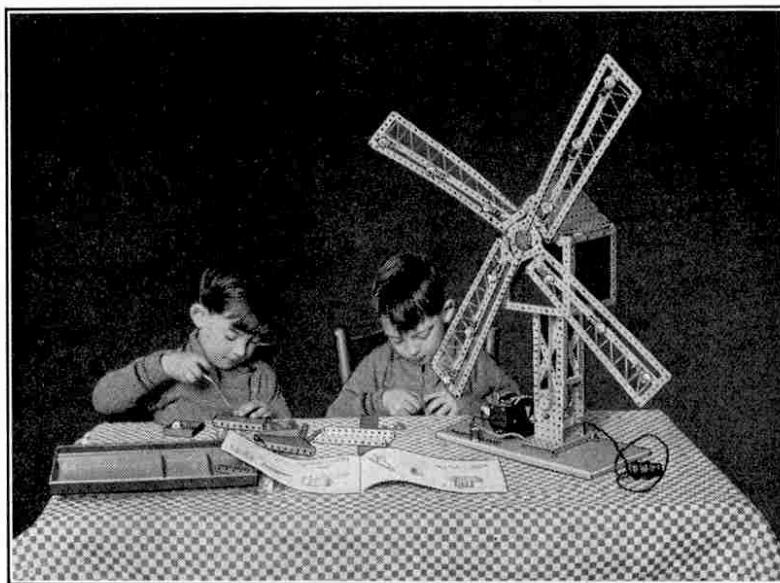

Our photograph shows the twins, John and Alan Robinson, the sons of our Paris Manager. They will be six years old in May and they both speak excellent English and French.

Needless to say, John and Alan are enthusiasts about Meccano, with which they made their first acquaintance when 18 months of age. A Meccano axle rod and a pulley wheel kept them occupied for hours on a railway journey from London to Liverpool!

The boys are very similar in appearance, and of course this leads to many amusing incidents. When they started school the teacher had to ask them their names two days running; the third day, when the question was again asked, Alan replied: "The same as they were yesterday—John and Alan."

Nothing delights them more than a visit to the model-room of our Paris Office and they are both decidedly of the opinion that the Limousine will always be their favourite model.

#### Rennie's Canals

The Kennet and Avon Canal has a total length of 57 miles and it rises 210 ft. by 31 locks to the summit level and descends 404 ft. on the west side by 48 locks. At the summit it was found necessary to construct a tunnel 500 yds. in length approached by deep cuttings.

Between Wootton Rivers and Devizes the canal had to be cut through chalk and sand and great difficulty was experienced in forming a watertight bed. Even more serious trouble was encountered near Bradford through land slips, and on one occasion seven acres of land slid into the canal and forced the whole down into the river below. This difficulty was surmounted by carrying an elaborate series of small tunnels and cross drains into the hillside. Perhaps the finest architectural feature of the canal was the aqueduct over the river Avon about six miles from Bath.

Among other canals constructed by Rennie was the Rochdale Canal opening up direct water communication between West Yorkshire and South Lancashire. This Canal had to cross the intervening mountain range over which it was lifted from lock to lock. The engineering difficulties involved in the cutting of this canal were indeed very great and the completion of the navigation in December 1804 was rightly regarded as a remarkable piece of work.

Rennie also constructed the Lancaster Canal with its handsome aqueduct over the River Lune. A survey for this canal had been made by Brindley in 1772, but

nothing was done until some twenty years later when a canal company was formed with Rennie as engineer. The aqueduct over the Lune is the principal architectural work on the canal. It consists of five semi-circular arches each of 75 ft. span, the surface of the canal being 62 ft. above the average level of the river. The total length of the aqueduct is 600 ft.

Another of Rennie's canals had a curious origin. A waterway known as the Grand Canal had been constructed to connect the navigations of the Liffey and the Shannon, and although it was badly designed it proved profitable. Among the committee of management was a retired shoemaker who upset his colleagues by meddling with the result that he was snubbed on every possible occasion. The shoemaker was furious at this treatment, threw up his seat on the committee and announced his intention of starting a rival canal. He was laughed at, but he set to work, organised a company and succeeded in obtaining an Act of Parliament authorising the construction of the Royal Canal of Ireland from Dublin to the Shannon near Longford.

The works were commenced, but unfortunately they were carried out so badly that matters came to an utter standstill. Rennie was then called in and, after overcoming great difficulties caused by the mistakes of the original constructors, he successfully completed the waterway. The shoemaker obtained his revenge by diverting traffic from the Grand Canal, but at the cost of heavy financial loss to many individuals and the almost entire loss of his own fortune.



# To Break the Ice at Riga

## Powerful New Ship Now Being Built for Latvia

**A**N ice-breaker of a novel and particularly interesting type is being built at Dalmuir by Messrs. Wm. Beardmore & Co. Ltd., for the Government of Latvia. The vessel, which is named "*Krisjanis Valdemars*," is intended for ice-breaking service in the Gulf of Riga. Her principal dimensions are as follows:—

Length on water-line 185 ft.,  
Breadth 54 ft.,  
Depth moulded to upper deck 28 ft. 6 in.,  
Normal draught 22 ft.,  
Normal displacement (about) 2,800 tons.

### Specially Designed Stem

The "*Krisjanis Valdemars*" has a specially-designed stem with considerable rake under the waterline. Her stern is of the cruiser type, both stem and stern post being of cast steel reinforced as necessary for ice-breaking purposes.

The framing, which is on the deep-frame principle, is exceptionally strong, the spacing of the frames being 18 in. apart amidships, and only 12 in. apart at the ends. The shell plating is also much in excess of the usual requirements, while the ice belt from about 6 ft. above the water line to about 9 ft. below is 1 in. in thickness, both fore and aft, the end plating down to the keel line being practically of the same thickness.

In addition to heavy, closely-spaced watertight bulkheads, there are, on each side of the vessel for about three-quarters of her length amidships, longitudinal watertight bulkheads, forming coal bunkers and water ballast tanks. By rapidly transferring water from the end tanks forward to the end tanks aft, or vice versa, the vessel may be quickly trimmed either way. Similarly, by transferring water from the tanks on one side to the tanks on the other side the vessel may be quickly heeled. By this means she is able to free herself in the event of becoming locked in ice.

### Towing Arrangements

Special arrangements are made for taking a vessel in tow. A recess is provided in the stern into which the stem of the following vessel may be drawn and held

in that position by means of a towing winch of exceptional power fitted on top of the after deckhouse.

An electrically-driven submersible salvage pump with a capacity of about 200 tons per hour is provided, with arrangements for transferring it to a vessel in tow or alongside so as to render effective assistance in case of damage.

### Novel Forward Propeller

The vessel is provided with two sets of triple expansion engines, one for driving the after propeller and one for the forward propeller. Steam is supplied by four boilers working under forced draught, and smoke-box superheaters are fitted to provide a moderate amount of superheat.

The principal functions of the after engine, which is capable of developing about 4000 i.h.p.,

are to propel and manœuvre the vessel. The forward engine, which is used to drive the forward propeller and to assist in the propulsion of the vessel, is capable of developing about 1,500 i.h.p. It is anticipated that these two engines working together will give the vessel a normal speed of about 14½ knots.

The forward propeller is fitted primarily to assist in ice-breaking. When the stem of the vessel is on the ice the propeller acts as a suction pump and sucks the water away from under the ice. The support of the ice is thus withdrawn, and the weight of the vessel, together with the pressure of the water ballast transferred forward, will break down the ice and enable the vessel to forge ahead, thus clearing and keeping open a passage for other ships navigating those waters.

### Electric Light Throughout

A very complete equipment of auxiliary machinery is provided, including two large centrifugal pumps for transferring water ballast from one set of tanks to another. Electric light is fitted throughout and the vessel has also a wireless installation and a powerful searchlight.

It is hoped that the new ice-breaker will render the port of Riga navigable at all seasons.

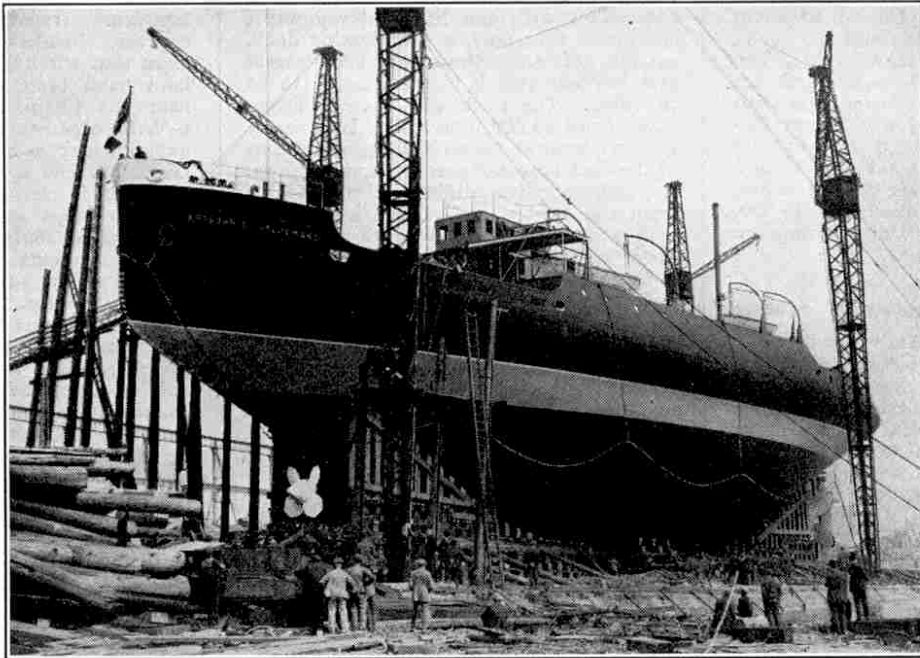

The "*Krisjanis Valdemars*" on the Stocks at Dalmuir

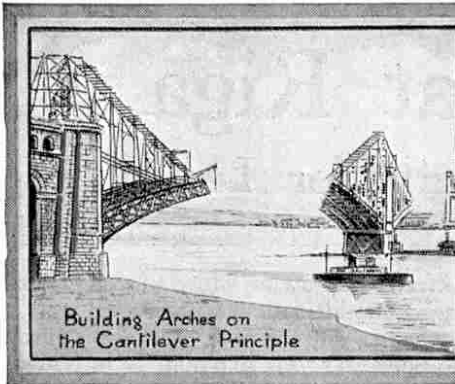

# Engineering News

## of the Month

### World's Production of Aluminium

The total world's production of bauxite in 1923 was estimated at 1,146,777 metric tons. Of this total the United Kingdom produced about 4,000 tons and the whole British Empire about 112,605 tons. The largest producer was the United States with 531,053 tons, France being next with 314,330 tons. The total world's production of aluminium in 1923 was 183,892 metric tons. Of this total the United States produced 97,000 tons, Canada 16,500, Germany 16,100, Switzerland 15,000, France 12,000, and the United Kingdom 8,500.

\* \* \* \*

### Port of London Improvement Scheme

The Port of London Authority recently announced a big improvement scheme for the India and Millwall Docks. This involves the construction of a new entrance to the South-West India Dock, 500 ft. in length and 80 ft. in width by 35 ft. in depth at Trinity high water. Passages will be constructed to enable the largest vessels, capable of navigating so far up the river, to proceed to any part of this system of docks, comprising a water area of over 127 acres.

\* \* \* \*

### New Hudson Tunnel

Great public interest was aroused in a model of the vehicular tunnel now being constructed under the Hudson River, exhibited at the National Automobile Show in New York the other day. This great engineering feat will be completed some time next year, and is expected greatly to improve traffic conditions between the States of New York and New Jersey, the popularity of the resorts in the latter State having brought motor-car traffic far beyond the capacity of the existing ferry service.

There will be two tunnels, one for east-bound and one for westbound traffic. Each will be 29 ft. 6 in. in width, and 9,250 ft. in length. The roadways will be 20 ft. in width, with an overhead clearance of 13 ft. 6 in. The ventilating system, which consists of air ducts at the top and bottom of each tunnel, will take up the remainder of the space.

\* \* \* \*

### Empire's Largest Clock

The clock in the tower of the Singer Buildings at Clydebank has at last been converted to electrical working. This clock is the largest in the British Empire, having four dials, each 26 ft. in diameter, which is 6 ft. more than the famous Liver Building clock in Liverpool, and 8 ft. 6 in. bigger than "Big Ben."

### Floating Dock for Singapore

In addition to the large graving dock that is to be constructed at Singapore in connection with the Naval development scheme at that port, a new floating dock, capable of accommodating the largest and heaviest vessels in the fleet, is to be provided. The dock will have a lifting capacity of 50,000 tons and it is probable that its general design will resemble that of the dock now stationed at Southampton. To overcome the difficulties inseparable from the towing of so huge a structure over a distance of 8,000 miles across the open ocean, it is anticipated that the dock will be shipped in parts to Singapore and assembled there, but so far no definite decision has been made upon this point. The cost of the new dock is estimated unofficially at £1,000,000 and the placing of the contract will give a useful flip to the steel trade, as one of the conditions of the contract will be that only British steel is to be used.

\* \* \* \*

### New Union-Castle Liner

The new Union-Castle liner "*Llandoverly Castle*" is now on her maiden voyage from London for South and East Africa. Her principal dimensions are:—Length 487 ft., breadth 61 ft. 6 in. and depth 42 ft. 6 in. with a gross tonnage of 10,609. She is constructed of steel throughout and has three complete steel decks—a lower deck, promenade deck, and boat deck. The double bottom extends the whole length of the ship, and eight watertight bulkheads are fitted to the shade deck. In order to give maximum security against accidents, all bulkhead doors below the water line are electrically controlled from the bridge.

\* \* \* \*

### Rugby Wireless Station

The Western Electric Company have recently completed the wireless telephony station at Rugby, which, when proved satisfactory, is to be used for telephonic communication with the United States.

The Company effected communication between America and this country some two years ago, and tests appeared to show that with their single-side band system, continual communication could be maintained between both countries.

An experimental test of the new station was carried out during the first week in March and extremely promising results were obtained. Conversations took place between the G.P.O. in London and the New York Headquarters of the American Telegraph and Telephone Company, and in our next issue we hope to be in a position to give fuller details.

### Sea to Home by Telephone

In a railway note this month we mention experiments in the receiving of broadcast transmission on a G.W.R. express. Readers will be interested to learn that wireless talks between ship and land have been successfully carried out near the Channel Islands, between the G.W.R. steamship "*Reindeer*" and an experimenter in a house in the island of Guernsey. As a result of these experiments it is claimed that communication between ships at sea and a telephone exchange on shore is a proved possibility, messages having been clearly exchanged over a radius of from 10 to 70 miles.

The inventor of the apparatus, Mr. D. V. S. Shannon, claims that the advantages of his system of wireless telephony are that the apparatus is portable and requires neither aerial nor earth connection; transmitting and receiving sets may be combined in one small case if desired; no re-radiation takes place and, if other circuits are in close proximity, no interference is experienced.

All these tests were made with the remarkably small power of from 5 to 7 watts input, using dry batteries, and the use of the apparatus enabled the ordinary land telephone to be picked up and conversation carried on between a telephone subscriber and friends on board a steamer. The set may be operated on very low wavelengths and, owing to its great selectivity, a considerable number of stations can be accommodated on a very narrow wave band.

\* \* \* \*

### A Remarkable Ship Repair

The steamship "*City of Singapore*" one of the Ellerman-Hall Line steamers, has just taken her place with the fleet after an interval of 20 months. In April 1924 an explosion and subsequent fire in her engine room occurred at Adelaide and as a consequence the vessel was seriously damaged, her engines being practically destroyed. It appeared very doubtful if she could be saved, but eventually she was salvaged and temporarily patched up.

A little more than a year after her accident the "*City of Singapore*" left Adelaide en route for Rotterdam, under the escort of a Dutch tug, and accomplished the journey of 13,000 miles in 4½ months, nearly two months longer than was anticipated. On her arrival, work on her was at once begun by the Rotterdam Dry Dock Company, and in order to carry out the extensive repairs that were required it was necessary practically to cut the ship in two.

**British Wireless Triumph**

In these columns from time to time we have commented upon the progress made at the great new Post Office wireless station at Rugby. Our readers will be interested to learn that a new service for the despatch from that station of wireless messages to ships at sea, all over the world, has just been inaugurated. In order to achieve this, the transmission has been centralised in the Central Telegraph Office, London. All messages are sent at midnight and noon, the operator being provided with a loud speaker by means of which he is able to know whether the transmission from Rugby is satisfactory. Owing to the great power required to transmit messages over such huge distances it will not be possible to obtain acknowledgment of the receipt of the messages, but nevertheless the Post Office authorities are confident that they can attain the maximum of efficiency.

An interesting point in connection with this transmission is that the private messages sent out at 12 midday will be repeated at midnight and those issued at midnight will be transmitted at midday, thus overcoming, as far as possible, any risk of a message failing to reach its destination through local or general atmospheric disturbances. The wavelength upon which this service is being worked is 18,700 metres, and the rate of transmission is fixed at a speed at which any properly trained operator can receive, perforated tape being used in order to ensure perfect formation of each signal issued.

It is hoped to commence a new night and day service to Canada and South Africa on the first of next month, and to Australia and India about three months later, this new service being worked on the "beam" system.

\* \* \* \*

**Mass Production of Motor Cars**

The production of motor cars in America in 1924 was 3,240,000, and in replacements alone there were 2,000,000 cars made each year. The American manufacturers co-operate with the Chambers of Commerce and the transport authorities, and their methods of production are amazingly advanced. English cars generally are at a discount in America and Canada, where there are few cars of so small a horse-power as twelve.

\* \* \* \*

**Steel Frame Building without Rivets**

A two-storey steel frame building, measuring 100 ft. by 150 ft., has been built at Canton, Ohio, without the use of a single riveted joint. The structure has been put together entirely by means of electric arc welding, resulting in a saving in cost of nearly 23 per cent.

**Pink Concrete Streets**

The Malden and Coombe Urban District Council are constructing new streets in concrete, and have just completed one with a pink surface, the object being to harmonise the streets with the pavement stones, which are of a reddish colour.

**Cape to Cairo by Motor Car**

For the first time the journey from Cape Town to Cairo has been covered by motor car. The expedition that accomplished this feat was British, being under the command of Major Court Treatt. The cars used were Crossleys and the whole of the equipment was made in Great Britain. The cars came through without mishap, a wonderful tribute to the all-round reliability of British products.

Owing to very heavy rains in many places, which reduced the country to almost impenetrable swamps, the journey took sixteen months instead of the originally estimated period of six. The object of the expedition was mainly to investigate the possibilities of a great central highway, and to obtain scientific and other information concerning this hitherto unblazed trail. Cinema and photographic records were made.

There had been two previous attempts to make the journey, one in 1909 having to be abandoned owing to its leader being severely mauled by a leopard, while in 1913 another British party was compelled to postpone the attempt owing to sickness and the outbreak of war.

Mrs. Court Treatt, who accompanied her husband throughout the trip, was the first white woman seen in many parts of the Sudan.

\* \* \* \*

**A Fine Towing Feat**

During the terrific gales that raged in the North Atlantic in the latter days of January and early days of February, a remarkable towing feat was accomplished. The Pacific Steam Navigation Company's liner "Magellan," encountered the steamer "Renaico" and a tugboat in distress during a gale near Valparaiso. The "Renaico" was bound for Iquique in charge of the tug, but owing to the heavy gale the tug had lost control of her.

In response to urgent signals the "Magellan" hove to windward of the unmanageable vessels, and by good seamanship succeeded in attaching a towing hawser. Then commenced a heavy fight against wind and sea, for it was necessary for the "Magellan" to sail directly into the teeth of the gale in order to reach the nearest port. During the fight, the hawser snapped but communication was soon re-established, and after a strenuous twelve hours, the Pacific Company's vessel succeeded in bringing her two charges into Valparaiso.

This is one of many similar determined efforts performed in the face of danger and unfortunately, often accompanied by loss of life.

**First Rotor Pleasure Yacht**

[Courtesy]

["The Motor Boat"]

Our readers will remember that we fully described the Flettner rotor ship in our January issue, 1925. The Flettner principle has now been applied with some success to yachts, as our illustration shows.

**New Manchester Telephone Exchange**

The contract for the erection of a new telephone exchange at Manchester has been placed by H.M. Office of Works. Among the material required for the construction will be 4,000 tons of steel, and the building will comprise ten floors with a capacity for a staff of 1,500 and a total of 30,000 telephone lines. This new exchange will take three years to build and is being put in hand now in view of the projected change from the manual to the automatic system.

\* \* \* \*

**Rapid Cargo Handling**

The Mersey-side dockers are noted for the expedition with which they can handle cargoes when the situation calls for extremely rapid work.

The steamer "Trinacria," carrying 2,840 tons of phosphate rock, was completely unloaded in twelve working hours at the Birkenhead docks. In these days of rivalry between ports, it is interesting to note that Birkenhead is still pre-eminent in the rapid discharge of berth cargoes, a speed of 3,000 tons in twenty-four hours being the ordinary rate of discharge with hydraulic grabs.



# Electricity

## XXV. AUTOMATIC TELEPHONY

WE have already described in this series how a manual telephone exchange is operated in order to secure the connection of any two subscribers who wish to speak to one another. This system is employed at the present time in thousands of exchanges throughout the world. Although it entails the employment of a fairly large staff of operators, it represents an enormous advance on the system used in the early days of telephony, particularly in the employment of various automatic devices to assist and speed up the service.

### The First Automatic Exchange

Rapidly as the telephone system advanced, telephone engineers were not satisfied, for they had visions of automatic systems in which the exchanges would require no operators, subscribers making their own connections by means of simple switching arrangements in their own homes.

For a long time such a development appeared impossible, but on 10th March 1891, Mr. Strowger entered in the United States Patent Office a patent for an automatic exchange, and the vision then became a reality. It is true that this first system required five connecting wires between each subscriber and the exchange, but eventually these were reduced to two, and so far as the subscribers' wire plant was concerned it became as economical as the Manual system.

Since that time many successful systems of automatic telephony have been invented and installed in exchanges of all sizes. Each of these systems has its own particular advantages and disadvantages but it safely may be said that the Strowger system is the most popular at the present day. After exhaustive tests a further development of this system has been adopted by the engineers of the British Post Office for the complex network of automatic exchanges now in course of erection to serve the vast area of London, as will be described next month.

### The Strowger System

Over one-and-a-half million Strowger automatic

telephones are in operation throughout the world, the largest network being, we believe, that at Los Angeles, California, with 90,000 lines. Some of the most important exchanges on this system in Great Britain are at Accrington, Newport (Mon.), Chepstow, Portsmouth, Paisley, Blackburn, Leeds and York, all of which were erected for the British Post Office by the Automatic Telephone Manufacturing Co. Ltd. of Liverpool. Further exchanges proposed or in course of erection are those constituting the London network, comprising nearly 160,000 lines, Bath, Birmingham, Brighton, Bristol, Edinburgh, Leicester, Liverpool, Manchester, Newcastle, Nottingham, Sheffield, Southport, and thirty-three other areas.

We intend to confine our description of automatic exchanges to the Strowger system as being the most important, and we are indebted to Automatic Telephone Manufacturing Co. Ltd., pioneers and principal manufacturers of the Strowger system in this country, for the illustrations to this article and also for much useful information.

The Strowger system accomplishes the automatic switching by means of sluggish and quick-acting relays respectively, the movements of which are controlled by various electro-mechanisms. Since the circuit connections are very complicated we do not intend to describe them here but will confine our attention to tracing the sequence of events that takes place in making

a call through a Strowger automatic exchange.

The apparatus consists of a number of easily replaceable units and the exchange is capable of being readily extended by the installation of additional units. The subscriber himself transmits the required number to the exchange electrically, and this has the advantage over a manual exchange that no errors due to mistaken pronunciation of figures or words are possible. The subscriber has only himself to blame if he finds himself connected to the wrong number!

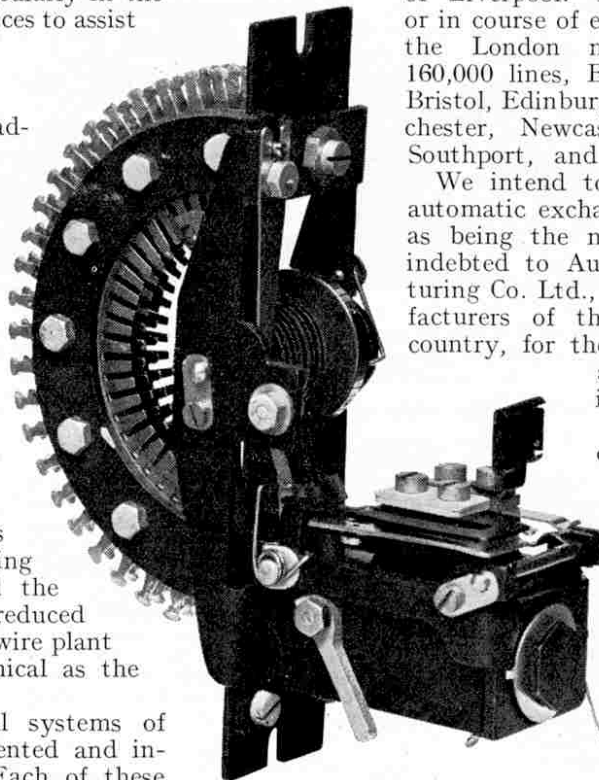

Fig. 1