

Meccano Suggestions Section

By "Spanner"

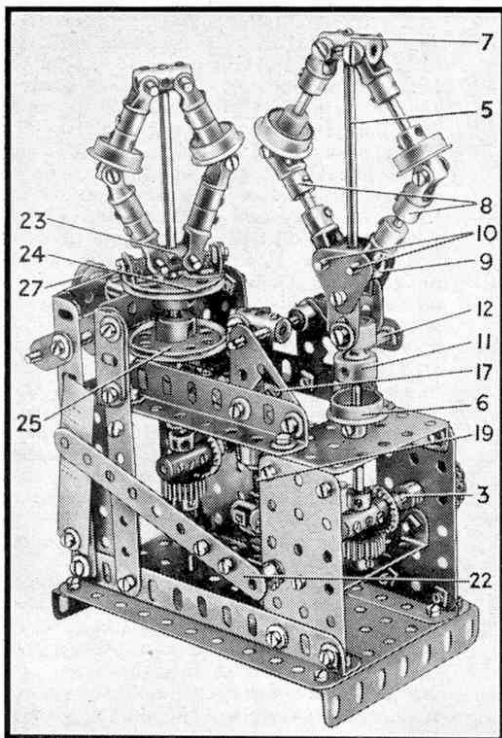

Fig. 447

(447) Knowle's Supplementary Governor

The mechanism shown in Fig. 447 is a reproduction in Meccano of Knowle's Supplementary Governor, a device that regulates the speed of a steam engine when the steam pressure falls below a certain value or there is a correspondingly unwanted increase. It really consists of two separate governors, known as the primary and supplementary governors, which operate in conjunction with each other. The two governors are driven by a Crank 1, Fig. 447a. Shafts 2 and 3 are connected by Sprocket Chain, and shaft 3 carries a $\frac{3}{4}$ " Contrate that drives a $\frac{3}{4}$ " Pinion on the vertical 8" Rod 5. This Rod is journalled at its lower end in a $2\frac{1}{2}$ " x $\frac{1}{2}$ " Double Angle Strip and also in a $2\frac{1}{2}$ " x $1\frac{1}{2}$ " Flanged Plate, a $\frac{3}{4}$ " Flanged Wheel 6 is fitted to the Rod and immediately above this is secured the primary governor proper.

Two Small Fork Pieces are pivotally secured to a Coupling 7 by means of Pivot Bolts, and in the bosses of the Fork Pieces are gripped $1\frac{1}{2}$ " Rods. Each Rod carries a $\frac{1}{2}$ " fast Pulley and a $\frac{3}{4}$ " Flanged Wheel to form a weight. In the tapped holes of the Flanged Wheel two special set-screws removed from Swivel Bearings, are fixed, and these form pivots for a Small Fork Piece 8. The latter is attached to a second Fork Piece by means of a 1" Rod, the fork of the second Fork Piece being fitted over the Coupling 9, where it is held in place by a Rod 10.

The two Rods 10 support two 1" Triangular Plates, to the lower corners of which Flat Brackets are bolted. The Flat Brackets are also attached as shown to a Socket Coupling 11, which is free to slide up and down the Rod 5.

The groove in the Socket

Coupling 11 accommodates one end of the Threaded Pin 12, which is locked in the end hole of a 2" Strip bolted to a Crank. The Crank is secured on a 2" Rod 13 that carries a Coupling 14, as shown in Fig. 447a. The end plain hole of this Coupling is fitted with a Pivot Bolt, on each end of which is supported a Flat Bracket. The two Flat Brackets are bolted rigidly to a Small Fork Piece 15, in the boss of which a 1" Rod is free to turn. This Rod is held in place by a Collar 16 and a 1" fast Pulley 17, a Washer being used for spacing purposes between the Pulley and Small Fork Piece.

The boss of the Pulley 17, which projects downwards, is gripped in one end of a Socket Coupling 18. The other end of this latter part is fitted with a Threaded Boss, into which is screwed the Threaded Rod 19. The unoccupied end

of the Threaded Rod is fixed by means of a nut in one of the threaded holes of a Collar, which is secured by a Pivot Bolt to a 2" Strip 20. A Crank, to which this Strip is fixed transmits the vertical movement of the Socket Coupling 18 to the Rod 21, on the end of which is secured the pointer 22. This pointer is fitted in place of the throttle lever of the actual mechanism, in order to indicate the amount of correction made by the supplementary governor.

The second or supplementary governor, which is shown on the left in Fig. 447, is driven in a similar manner to the primary governor, and its construction is almost identical. The Coupling 23 is attached by two $\frac{3}{8}$ " Bolts and Angle Brackets to a $1\frac{1}{2}$ " Pulley 24. A Socket Coupling connects this Pulley to a similar part 25.

A Coupling 26, Fig. 447a, carries a Dinky Toys Motor Tyre, and as the governor rises and falls the Tyre is rotated by one or the

other of the Pulleys 24 and 25. This turning movement is transmitted to the 1" fast Pulley 17 by a length of light cord or cotton, which passes around the fast Pulley 27 and the loose Pulleys 28. The operation of a governor of this kind is as follows. If the load on the engine to which it is fitted suddenly falls, or the steam pressure rises beyond normal, the supplementary governor rotates the Pulley 17 in an anti-clockwise direction. This movement unscrews the Threaded Rod 19 from its Threaded Boss and partially closes the throttle, thus cutting down the steam supply and adjusting the speed of the engine to its normal value. Control is then taken up again by the primary governor. If the load on the engine is increased or

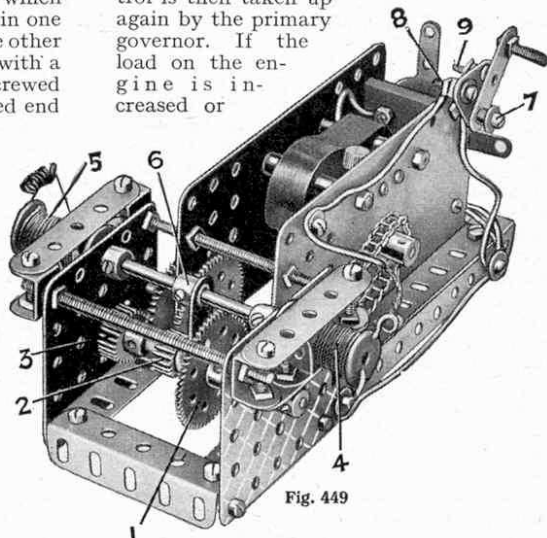

Fig. 449

the steam pressure falls, the reverse action takes place.

(448) Axle Springing

(W. Henry, Toronto, Canada)

The attention paid by car designers to suspension systems has aroused the interest of the Meccano enthusiast, for he too is concerned with the inclusion of a complete true-to-type suspension system in his model vehicle.

Fig. 448, on the opposite page, shows a suspension of the swinging axle type that is suitable for heavy model carts or motor cars. The axles are mounted on a beam consisting of two $3\frac{1}{2}$ " Strips spaced apart by Double Brackets, and fitted in the middle with two Flat Trunnions. The axles, $2\frac{1}{2}$ " Strips spaced by Double Brackets, are pivotally mounted on a 1" Rod that passes through the Flat Trunnions and are connected to the beam by $1\frac{1}{2}$ " Rods 1, on which are fitted Compression Springs. An Aeroplane Collar is fixed on each end of the Rods. The bolts holding the Double Brackets carry two washers under their heads, so that the Collars have free movement.

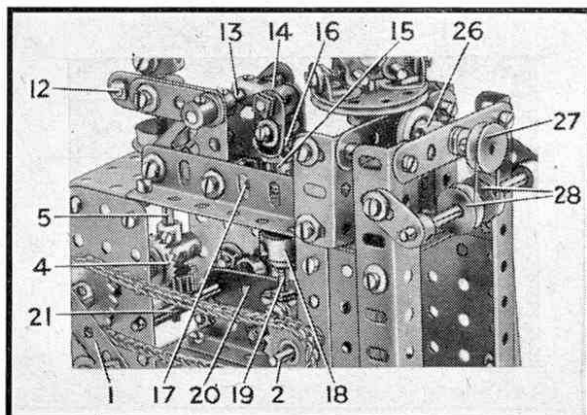

Fig. 447a

(449) Remote Control for Gear-Box

(L. F. Atkinson, Croydon)

The remote controller for an Electric Motor described in "Suggestions Section" for July 1939 aroused much interest and Fig. 449 shows another device for this purpose. The mechanism is intended for operating a two-speed gear-box from a distance, and in a model with several movements it will be necessary to fit a controller for each movement.

The two-speed gear-box shown in the illustration is mounted between 2 1/2" x 2 1/2" Flat Plates and the Motor side plates. The drive from the armature shaft of the Motor is conveyed through Sprocket gearing to a 1 1/2" Rod journalled between one of the Motor side plates and a 2 1/2" x 2 1/2" Flat Plate. The Rod carries a 1/2" Pinion that is constantly in mesh with the Gear 1 on a sliding 3 1/2" Rod, which carries also a 1/2" Pinion 2 and a 3/4" Pinion 3. A Collar at each end limits its longitudinal movement. The final driven shaft consists of a further 1 1/2" Rod journalled coaxially with the first in the opposite Motor side plate and Flat Plate. The two Rods must be in proper alignment.

The selector consists of a Crank 6 the web of which fits between the Gear 1 and Pinion 2. It is spaced from the Gear by Washers. The boss of the Crank is fixed on a sliding Rod, the ends of which project beyond the Plates and are inserted in the solenoids 4 and 5. These are made from Meccano Bobbins wound with 23 SWG. copper wire and are clamped in position by 2 1/2" Strips secured at each end to Double Brackets. The lower Strips carry Angle Brackets centering the solenoids.

The gear control switch is shown near the Motor reversing switch for convenience, but can be taken to any position. A 1" Triangular Plate is held on a 3/8" Bolt 7 by two nuts, and two further nuts hold it in position on the Motor. Two 6 B.A. Bolts 8 and 9 are insulated from the Triangular Plates and form studs for the contact arm, made from a 1 1/2" Strip, which is mounted on the Bolt 7, and held against the heads of the 6 B.A. Bolts by a Compression Spring. The Bolt 8 is connected to one end of the wire of the solenoid 4, the other end of which is connected to one of the Motor terminals. The same Motor terminal is connected to the solenoid 5, which is wired to the Bolt 9.

One of the wires from the Transformer is connected to the remaining Motor terminal and the other is "earthed" by fixing it to the frame of the mechanism. With the lever as shown the solenoid 5 is in series with the Motor and causes the Crank 6 to bring the Pinion 2 into mesh with the 57-teeth Gear, at the same time throwing the Pinion 3 out of engagement with its respective Gear. The solenoid 4 is energised when the control lever is moved to the left to make contact with the Bolt 8 and this causes the Pinion 3 to engage with its Gear Wheel. The mechanism works only when the Motor is in operation.

(450) Bicycle Brake

(L. Dean, Northampton)

The model shown in Fig. 450 demonstrates the action of a simple form of bicycle brake, and if suitably strengthened could be put to practical use in model-building. It is easy to build and consists essentially of the two levers 1, which carry the brake blocks. These levers are built up of 4 1/2" Strips, duplicated for strength and lengthened with 2 1/2" Curved Strips, and they are pivoted by means of Pivot Bolts to a back-plate consisting of a 3 1/2" x 2 1/2" Flanged Plate and two Semi-Circular Plates. The back plate forms a support for the mechanism.

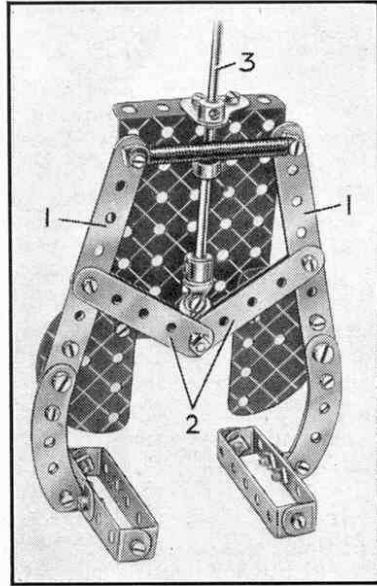

Fig. 450

The brake blocks, which are represented by 2 1/2" x 1 1/2" Double Angle Strips, are held apart by a Spring, but are forced into contact with the wheel rim by the two short levers 2, made from 2 1/2" Strips. The Rod 3 represents Bowden wire used in an actual brake of this kind, and when it is pulled up the resistance of the spring is overcome and the brakes applied. Bowden cable could be used instead of the Rod 3, or a substitute could easily be made by threading wire through a length of Spring Cord.

threading wire through a length of Spring Cord.

(451) A Simple Centrifugal Governor

(J. Rolfe, Ruabon)

A centrifugal governor is often very useful to limit the speed of the driving motor of a model to a certain value, especially in such models as roundabouts and big wheels. Model-builders therefore will be interested in details of a simple governor of this type used in small Clockwork Motors recently sent by J. Rolfe, Ruabon. In this the weight consists of a Rod Socket fitted with Washers fastened on the end of a 1 1/2" Rod. The Rod passes through a Coupling and carries at its other end a Compression Spring and Collar. The Coupling is fixed on a Rod driven by the driving motor, and a Boiler End is fixed to a framework so that the 1 1/2" Rod is housed inside it. In action the weighted end of the Rod swings outward by centrifugal force when the speed is too high and friction with the rim of the Boiler End then reduces the speed of the Motor.

An alternative scheme for controlling the speed of a Clockwork Motor is to use a fan brake. The fan consists of a Flexible Plate of suitable size fixed at its centre to an End Bearing. The latter is fastened on a Rod journalled in the Motor side plates and driven through a step-up gearing of 3:1. The air resistance to the fan is sufficient to keep the speed within the required limits.

Miscellaneous Suggestions

Under this heading "Spanner" replies to readers who submit interesting suggestions regarding new Meccano models or movements that he is unable to deal with more fully elsewhere. On occasion he offers comments and technical criticisms that, he trusts, will be accepted in the same spirit of mutual help in which they are advanced.

M.215. The Meccano Worm is intended primarily for use in gear trains to give a slow-speed drive, and its thread is cut to the pitch best suited for this purpose. Consequently it is not very suitable for operating steering mechanisms, as it requires a large number of turns to operate the wheels through a complete lock. A Worm with a greater pitch than the present one therefore is suggested by P. Johnson, Exeter, and others, but I think the constructional difficulty can be overcome by arranging for the Worm to turn a 1/2" Pinion on a short Rod that carries also a Crank fitted with a 1 1/2" Strip to form the drop arm. The latter is connected in the usual way to the steering arm.

M.216. R. Jones, Cardiff, points out that Float Tie-Rods, Aeroplane Constructor Part No. P57, make excellent tie-rods for bracing small Meccano structures such as bridges. The idea is a good one and no doubt other model-builders would like to try it out in practice.

M.217. Pivot Bolts fitted with cardboard discs at each end and wound with 26-SWG. S.C.C. copper wire make excellent miniature solenoids for operating relays and similar small electro-magnetic mechanisms. The scheme is suggested by N. Adams, Buxton.

M.218. When building small models to scale it is sometimes found that the Meccano Rods are too large in diameter to form neat handrails. Neat handrails can be made from Spring Cord, through the centre of which is passed a length of stiff wire such as the Elektron Connection Wire (Part No. 1566). Rails made in this way can be supported on 3/4" Bolts and may be bent to any desired shape. The idea is suggested by J. Phillips, Birmingham.

M.219. A compact and simple form of friction gearing used by H. Roberts, Warrington, consists of a 1" Pulley fitted with a 1" Rubber Ring arranged to engage with the inside rim of a Wheel Flange. A ratio of approximately 1.6:1 is obtained.

M.220. Meccano Rods can be used in conjunction with Elektron Magnet Coils if the diameter of the Rods is increased by

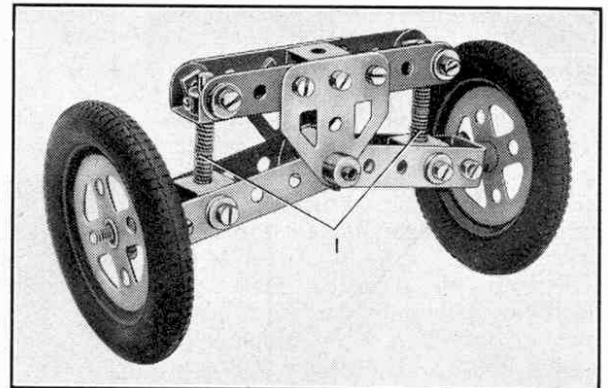

Fig. 448

fitting them with Aeroplane Collars (Part No. P52), which are a sliding fit in the bores of the Magnet Coils. Model-builders who use Magnet Coils in conjunction with Meccano parts will find this scheme very useful.