

"Spanner's" Special Section
for Juniors

Easy Model- Building

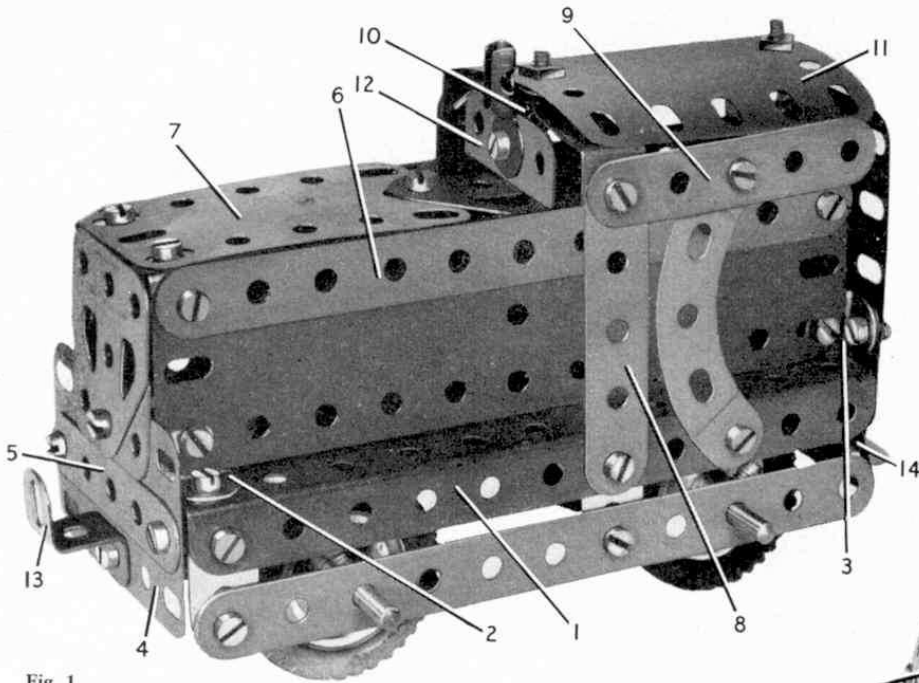

Fig. 1.

An easy-to-build model Diesel Locomotive. All the Parts contained in it are included in Outfit No. 2.

A Diesel Locomotive built from Outfit No. 2

Owners of an Outfit No. 2 or one larger will have all the parts required to assemble the attractive, but easy-to-build, Diesel Locomotive shown in Fig. 1.

The base of this model is a $5\frac{1}{2}'' \times 2\frac{1}{2}''$ Flanged Plate 1; on this two $5\frac{1}{2}'' \times 1\frac{1}{2}''$ Flexible Plates are fixed by Angle Brackets 2. To the back of the Flanged Plate is bolted a $2\frac{1}{2}'' \times 2\frac{1}{2}''$ Flexible Plate, which is also bolted to the $5\frac{1}{2}'' \times 1\frac{1}{2}''$ Plate by means of an Angle Bracket 3. A Flexible Plate 4 and a $2\frac{1}{2}''$ Strip 5 are bolted to the front of the Flanged Plate and to the front of the Plate 4 are fixed two Flat Trunnions as shown. A $5\frac{1}{2}''$ Strip 6 is bolted across the top of the $5\frac{1}{2}'' \times 1\frac{1}{2}''$ Flexible Plate, and a $2\frac{1}{2}'' \times 1\frac{1}{2}''$ Flexible Plate 7 is then fixed by Angle Brackets to the top of the tank as shown. Two $2\frac{1}{2}''$ Strips 8 are then bolted to the Flanged Plate and these are then joined at the top by a $2\frac{1}{2}'' \times \frac{1}{2}''$ Double Angle Strip, at the same time attaching the Strips 9. The Strips 9 are braced by $2\frac{1}{2}''$ Curved Stepped Strips. A second $2\frac{1}{2}'' \times \frac{1}{2}''$ Double Angle Strip 10 is then bolted to the one already mentioned. This runs from front to rear, and at the rear it is bolted to the $2\frac{1}{2}'' \times 2\frac{1}{2}''$ Flexible Plate. A $2\frac{1}{2}'' \times 2\frac{1}{2}''$ Plate 11 is then bolted to the top by $\frac{3}{8}''$ Bolts. The Plate should be given a slight curve and should be spaced from the Double Angle Strip 10 by two Washers at the front and three at the back. A Trunnion 12 is then attached to the Plate 7 and the Double Angle Strip 10, a Rod and Strip Connector also being attached. Two $5\frac{1}{2}''$ Strips are then bolted to the bottom of the Flanged Plate by two Fishplates, and the $3\frac{1}{2}''$ Rods that carry the Wheels are journalled in them. A Reversed Angle Bracket 13 is bolted to the front to form a coupling. A Trunnion is bolted to the rear of the Flanged Plate and to it are attached a $2\frac{1}{2}''$ Strip 14 and an Angle Bracket to form the rear coupling.

Parts required to build the Diesel Locomotive: 4 of No. 2; 6 of No. 5; 4 of No. 10; 7 of No. 12; 2 of No. 16; 4 of No. 22; 42 of No. 37a; 40 of No. 37b; 5 of No. 38; 2 of No. 48a; 1 of No. 52; 2 of No. 90a; 2 of No. 111c; 1 of No. 125; 2 of No. 126; 2 of No. 126a; 4 of No. 142c; 2 of No. 188; 2 of No. 189; 2 of No. 190; 2 of No. 212.

A Model Slotting Machine for Outfit No. 4

This is a model of a machine used by engineers for shaping pieces of metal fixed to a worktable. The metal is cut by a

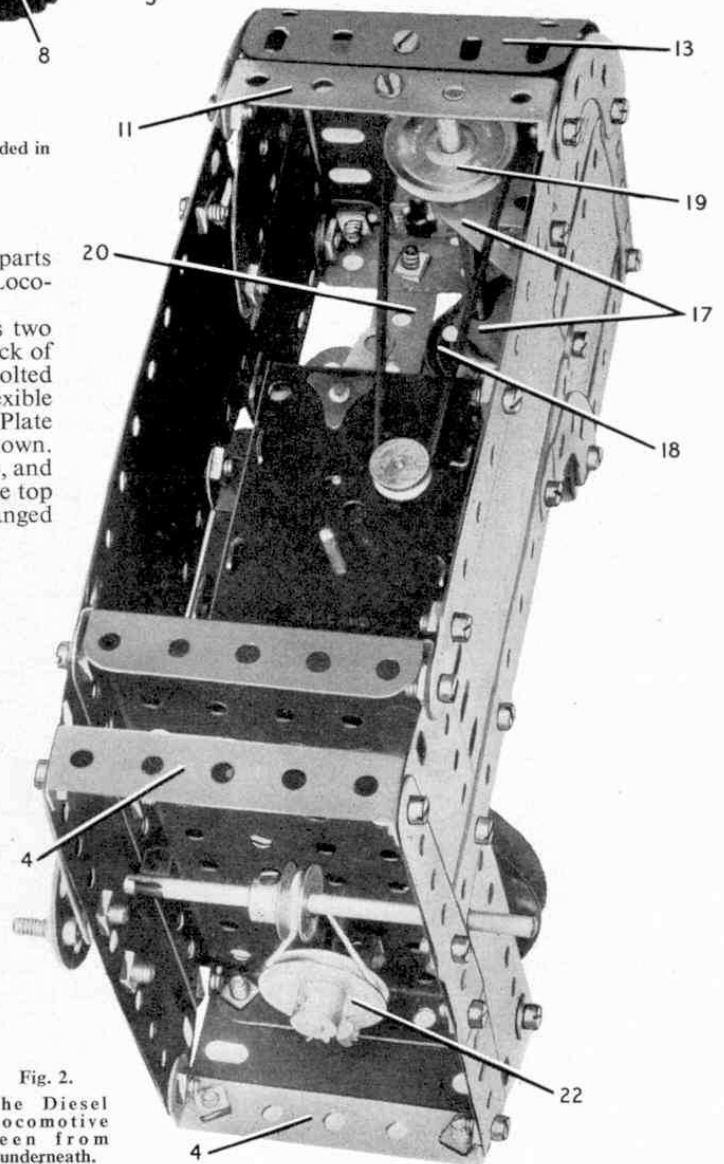

Fig. 2.

The Diesel Locomotive seen from underneath.