

A New Meccano Orrery

Illustrating the Motion of the Earth and Moon

AN astronomical instrument in which interest has recently been revived is the orrery, which illustrates the motion of the planets and their moons about the Sun. An instrument of this kind seems to have been first made slightly more than 200 years ago by a man named Graham and the first well-known example of it was constructed in 1715 by John Rowley for Charles Boyle, the Earl of Orrery, from whose title its name is derived. An excellent example of the apparatus, made about 1770 by Benjamin Martin, is to be seen in the Science and Art Museum, South Kensington.

Charles Boyle was a member of the famous family founded

by Richard Boyle, commonly known as the Great Earl of Cork. Richard Boyle was a great statesman whose active career in Ireland lasted from the time of the Armada in 1588 to the outbreak of civil war in the reign of Charles I. One of his sons was Robert Boyle, the famous chemist who was one of the founders of the Royal Society of London, while another was Lord Broghill, who so greatly distinguished himself as a soldier and statesman under Cromwell and Charles II. that he was made Earl of Orrery.

The Charles Boyle for whom the orrery was built combined some of the qualities of both these ancestors. He played a creditable part in public affairs in the early days of the eighteenth century and used to amuse himself during his leisure hours with mechanical toys.

The Functions of an Orrery

The orrery soon proved to be much more than a mechanical toy however. It is impossible to represent the solar system mechanically with absolute accuracy, of course, the great difficulty being the correct reproduction of the sizes and distances apart of the planets. If the Earth, for instance, in such an instrument is represented by a sphere of the diameter and weight of a halfpenny, the Sun would have to be a huge globe weighing considerably more than a

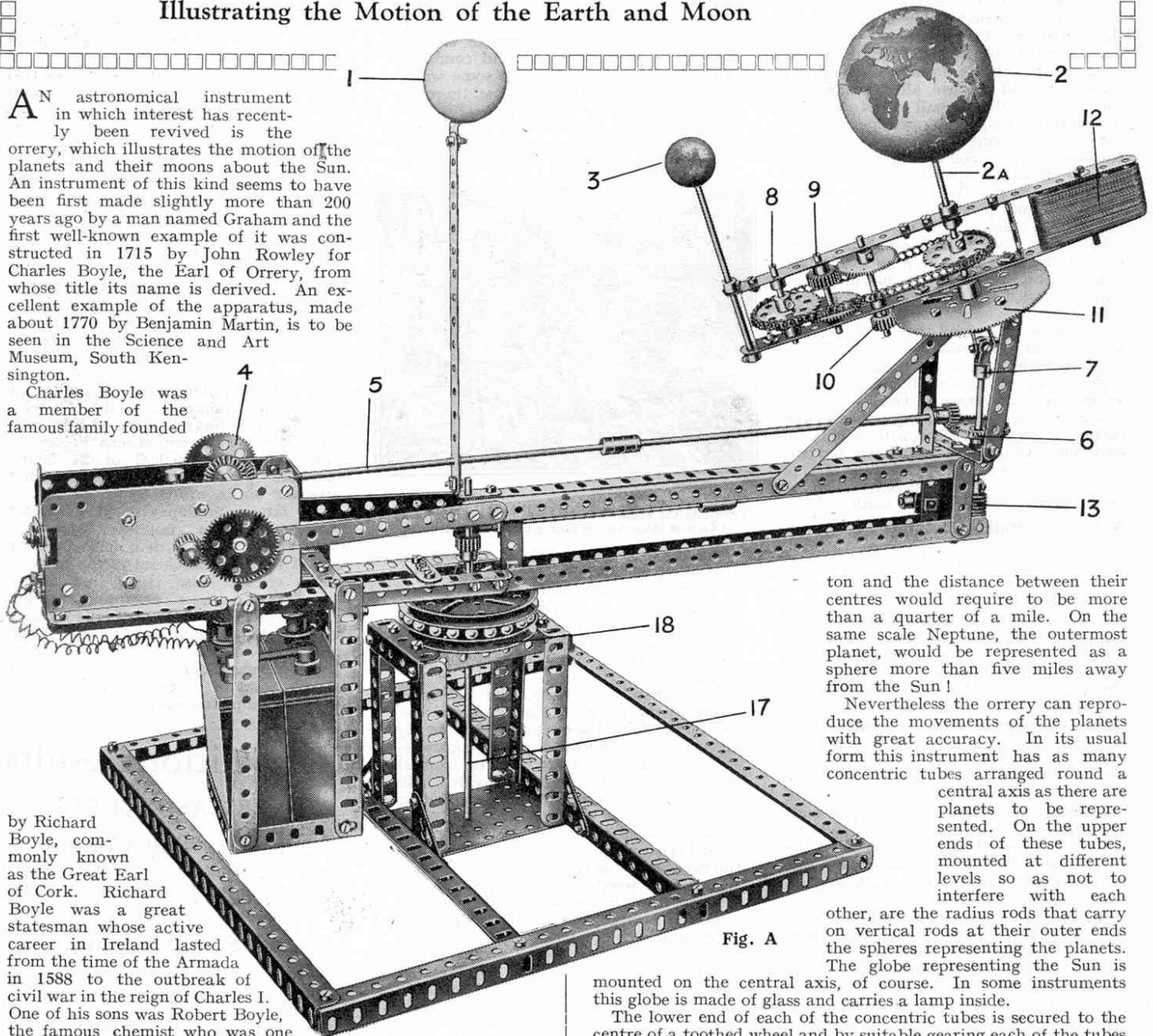

ton and the distance between their centres would require to be more than a quarter of a mile. On the same scale Neptune, the outermost planet, would be represented as a sphere more than five miles away from the Sun!

Nevertheless the orrery can reproduce the movements of the planets with great accuracy. In its usual form this instrument has as many concentric tubes arranged round a central axis as there are planets to be represented. On the upper ends of these tubes, mounted at different levels so as not to interfere with each

other, are the radius rods that carry on vertical rods at their outer ends the spheres representing the planets.

The globe representing the Sun is mounted on the central axis, of course. In some instruments this globe is made of glass and carries a lamp inside.

The lower end of each of the concentric tubes is secured to the centre of a toothed wheel and by suitable gearing each of the tubes is made to rotate round the Sun at the appropriate rate for the particular planet associated with it. Thus the tube carrying the sphere representing Jupiter is so geared that it rotates once while that carrying the sphere representative of the Earth travels round almost twelve times, thus indicating the difference between the periods in which these two planets complete their orbits.

More complications ensue when the rotations of the planets themselves and the movements of their moons are also to be represented. Even this can be done, however, and an orrery combining all these movements can be constructed without difficulty from standard Meccano parts.

The Movements of the Model

The model depicted on this page demonstrates the annual journey of the Earth and its satellite, the Moon, round the Sun, and is yet another remarkable illustration of the practical value of Meccano.

The movements to be represented are three in number. The

Fig. A

Earth rotates round the Sun in the same time that it takes to rotate upon its own axis 365 times, while the Moon makes 13 revolutions round the Earth in the same period. The Moon always presents the same face to the Earth, and the axis of the latter body is so inclined that there is an angle between the plane of the equator and that of the earth's orbit of $23\frac{1}{2}$ degrees. The Meccano model reproduces these movements and positions with considerable accuracy.

The Sun is indicated at 1, the Earth at 2, and the Moon at 3 (Fig. A). Suitable spheres or balls to represent these bodies may be obtained quite easily, and no trouble should be found in securing them to their respective shafts. The appearance of the model will be enhanced if the globes are painted to represent the markings on the surfaces of the Earth and Moon, etc.

The Motor is mounted at the end of the revolving portion, or arm, of the model and its weight, together with that of the Meccano 8 ampere-hour Accumulator slung in a suitable frame beneath the Motor, serves to counterbalance the weight of the Earth and Moon, etc., on the other end of the arm.

The drive is led first to the Earth spindle 2a by way of two 3:1 reduction gears mounted on the Motor, and Bevel Wheel 4. The latter engages with a similar wheel secured to the shaft 5, which consists of two 8" Rods secured together by a Coupling. The other end of this shaft 5 carries a $\frac{1}{2}$ " Pinion gearing with a $1\frac{1}{2}$ " Contrate Wheel 6 secured to a vertical Rod that is connected to the Earth spindle 2a by means of a Universal Coupling 7. This allows the Rod 2a to be placed at an angle corresponding to the "tilt" of the Earth's axis.

How the Moon is Operated

The motion of the spindle 2a is conveyed to a short Rod 8 by means of a length of Sprocket Chain and two $1\frac{1}{2}$ " Sprocket Wheels, and a $\frac{3}{4}$ " Pinion secured to this Rod 8 drives a 50-teeth Gear Wheel secured to another 2" Rod carrying the $\frac{3}{4}$ " Pinion 9. The latter, in turn, engages with another 50-teeth Gear Wheel secured to the shaft of the $\frac{3}{4}$ " Pinion 10, which engages with the teeth of a $3\frac{1}{2}$ " Gear Wheel 11. The Gear Wheel 11 is secured by Strips to the arm so that it cannot rotate, the Earth spindle being free to move within its boss, of course.

The gear train 8, 9, 10 is carried in an arm that pivots about the Rod 2a and since the Pinion 10, when in motion, must travel round the teeth of the immovable wheel 11, this arm together with the Moon 3 secured to its outer end, is caused to turn slowly round the Earth 2. The gear ratio is such that one complete revolution of the arm carrying the Moon takes place once in 28 revolutions of the Earth sphere 2. And since one revolution of the latter must indicate the passage of a single 24-hour day each complete circuit described by the sphere 2 corresponds to the 28-day lunar month.

The phenomenon of night, or the transit from daylight to

darkness that takes place over the greater portion of the earth's surface once in every 24 hours, may easily be illustrated by adding a small electric light in place of, or in addition to, the Sun globe 1.

In order to secure smooth working, the weight of the Moon and its gear train is counterbalanced by a series of $2\frac{1}{2}$ " Strips 12 mounted on the opposite end of the revolving arm.

Earth's Passage Round the Sun

Fig. B is a detail view of the model and shows the opposite side of the main revolving arm. From this illustration it will be seen that the lower portion of the Earth spindle carries a Worm 13 engaging with a $\frac{1}{2}$ " Pinion 14 that is secured to a short Rod 15 journaled in the end of the arm. This Pinion 14 gears with a similar Pinion mounted on the end of a shaft 15, consisting of two $6\frac{1}{2}$ " Rods secured end to end by a Coupling, on the other end of which is a second Worm 16 engaging with the teeth of a $\frac{1}{2}$ " Pinion secured to a vertical Rod 17.

This Rod 17 is gripped by the set-screw of the 3" Pulley 18,

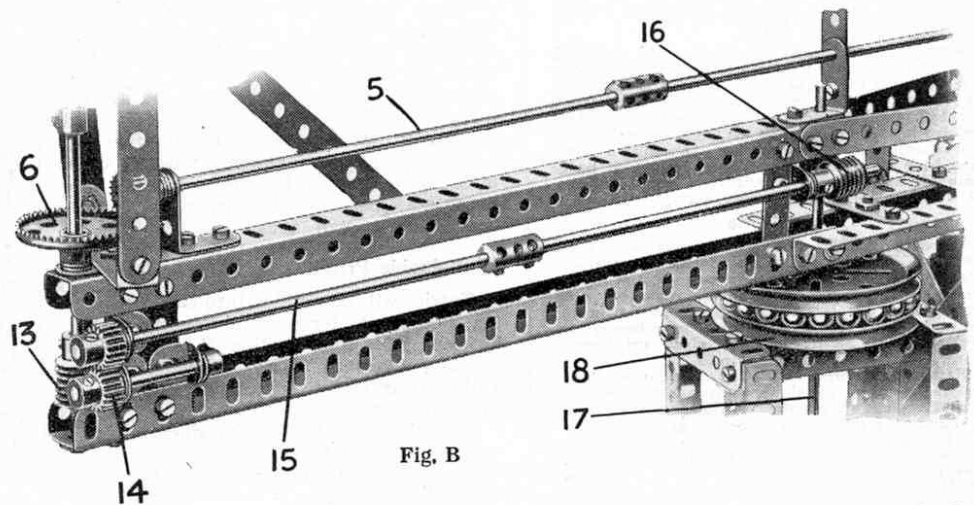

Fig. B

which is bolted to the base and forms the fixed race of the ball bearings on which the movable portion of the model rests. The construction of the ball bearing unit is identical to that described under Meccano Standard Mechanism No. 104/5, the upper 3" Pulley of the unit being secured to the rotating superstructure. The Worm 16 is driven very slowly from the motion of the Earth spindle and because the $\frac{1}{2}$ " Pinion with which it gears is quite rigid, it has the effect of turning the whole superstructure about the Rod 17. Thus the Earth 2 and Moon 3 are carried round the Sun 1.

The two separate worm gears incorporated in the drive transmission reduce the speed of rotation to such an extent that the Rod 2a must rotate 361 times before the superstructure completes one revolution. This closely approximates to the actual number required, for the Earth revolves 365 times about its own axis while journeying once round the Sun. The sum of these 365 turns, or days, makes what we term a year.

A Snapshot Competition

The many photographic enthusiasts among our readers will welcome the announcement that Gevaert Ltd., whose advertisement appears on page 568 of this issue, are organising a competition for snapshotters and are awarding valuable cash prizes each month for happy snapshots. Here is an excellent chance to make your camera pay for its season's upkeep.

The rules are very simple. Any size photograph is eligible and no entry forms are necessary. The only stipulation is that each photograph must be accompanied by a GAYVERT film carton. As many prints as desired may be entered at any time each month up to 30th September but a carton must accompany each. Full details of this competition appear in Gevaert Ltd.'s advertisement this month.

Wang's "Flexible Brain"!

The following letter was recently received by a financial house in Peking:—

"DEAR SIR,—I am Wang. It is for my personal benefit that I write for a position in your honourable Bank.

"I have a flexible brain that will adapt itself to your business and in consequence bring good efforts to your good selves. My education was impressed upon me in Peking University in which place I graduated Number One.

"I can drive a typewriter with a good noise and my English is great.

"My references are of good and should you hope to see me they will be read by you with great pleasure.

"My last job has left itself from me for the good reason that the large man has died. It was on account of no fault of mine. So, honourable sir, what about it? If I can be of big use to you, I will arrive on some date that you should guess.—Faithfully yours, 'WANG.'"

Important Babies at the Zoo

Among the outstanding possessions of the London Zoo is the recently-born East African buffalo. This interesting animal attracts a good deal of attention, as it is nearly 15 years since an East African buffalo was last born in the Zoo gardens.

Equally important is the baby hippopotamus and fortunately he is a much less delicate animal. In fact he is distinctly substantial for a baby and is now practically big enough to take care of himself. While younger he was the cause of a family separation. There was scarcely room enough in the small indoor tank in which these animals enjoy a bath for the two older hippopotami and there was a great risk that between them Jimmy would accidentally be crushed if he also ventured into the water. So they were separated, but soon it will be Jimmy's turn to live by himself.