

A New Meccano Loom

By "Spanner"

Motor Driven Weaves Real Cloth

I AM now able to give constructional details of a new Meccano weaving Loom that has been specially designed in response to many requests that I have received from Meccano enthusiasts. This Loom is easy to build and comparatively easy to adjust when completed, and it is one of the most simple automatic machines of this type that can be designed. Even so it is a complicated mechanism, and it is intended therefore as a subject for older model-builders. The shuttle used in the model is built up entirely from standard Meccano Parts.

The main constructional details of the model are given in this issue and next month I shall complete the instructions and give details for adjusting and working the Loom, together with details of a simple Beaming Frame that is required for preparing the warp ready for placing in position in the Loom.

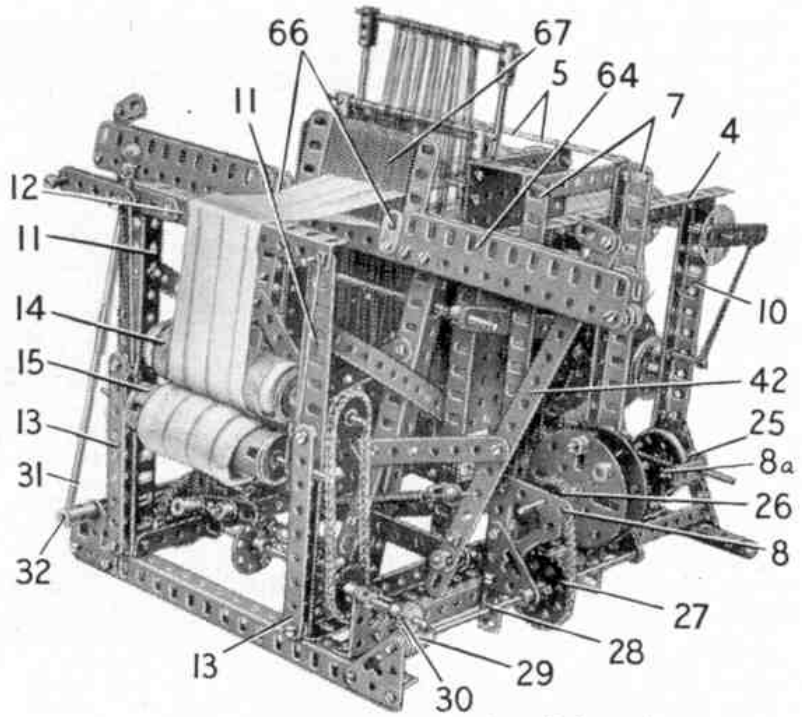

Fig. 1. The fine Meccano weaving loom described on these pages.

Construction of the Frame

The base of the frame (Fig. 2) is built from four $12\frac{1}{2}$ " Angle Girders bolted to two $9\frac{1}{2}$ " Angle Girders. Four $7\frac{1}{2}$ " Angle Girders 1 are bolted to the inside Angle Girders 2 and are held firm by two $5\frac{1}{2} \times 3\frac{1}{2}$ " Flat Plates 3, which support two $9\frac{1}{2}$ " Angle Girders 4 (see Figs. 1 and 2). Two $4\frac{1}{2} \times \frac{1}{2}$ " Double Angle Strips 5 are fixed between the Flat Plates 3. Bolted to the inside of the Flat Plates 3 are four $3\frac{1}{2}$ " Angle Girders 6 (Figs. 2 and 4), spaced from the Plates by three Washers on each bolt. Two $9\frac{1}{2}$ " Angle Girders 7 (Fig. 5), are secured to the base and connected to the top of the Plate 3 by $1\frac{1}{2} \times \frac{1}{2}$ " Double Angle Strips. Two Corner Gussets 8 and 8a and two $1\frac{1}{2}$ " Corner Brackets are bolted to the Girders 7 as shown in Figs. 1 and 5. To the Corner Gusset 8a two 1×1 " Angle Brackets are fixed, and these, together with two Girder Brackets 9, form the bearings for the driving shaft 24 to the heald tappets. Two $7\frac{1}{2}$ " compound girders 10 (Fig. 5), are bolted to the base and to the $9\frac{1}{2}$ " Angle Girders 4, and are braced to the base by $3\frac{1}{2}$ " Strips. At the other end of the base two $7\frac{1}{2}$ " compound girders 11 are fixed. These support the *breast beam*, which is a $5\frac{1}{2}$ " Angle Girder 12. To the girders 11 are also bolted

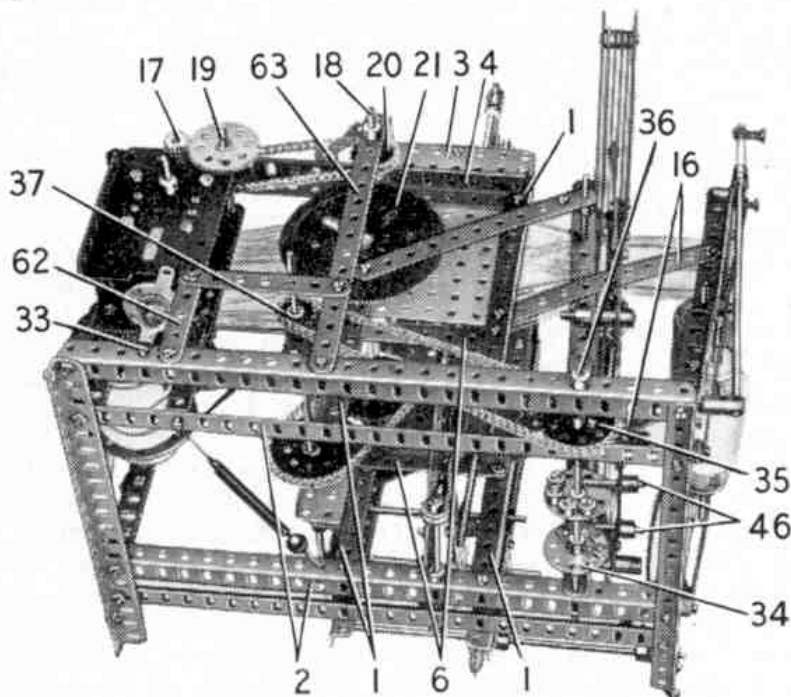

Fig. 2. The loom seen from below, to show details of the frame and the mounting for the E20R Electric Motor.

two $4\frac{1}{2}$ " Strips 13 spaced from the girders by four Washers on each of the Bolts. A lock for the Motor starting handle is a $2\frac{1}{2}$ " Strip mounted on Pivot Bolts and held by Compression Springs against a

on the Motor shaft engages with a 57-tooth Gear, on the shaft of which another $\frac{1}{2}$ " Pinion 17 drives a 57-tooth Gear on Rod 19, which also carries a 1" Sprocket. A Chain from this drives another 1" Sprocket 20 on Rod 18, which also carries a $\frac{1}{2}$ " Pinion that engages a $3\frac{1}{2}$ " Gear Wheel 21 on Rod 22 (Fig. 5). Rod 18 is supported in Strip 63 (Fig. 2), and one of the Flat Plates 3. Rod 22 (Fig. 5) has a 2" Sprocket 23 at its centre, and a $2\frac{1}{2}$ " Gear is fixed to the Rod at the opposite end to the Gear 21.

The $11\frac{1}{2}$ " Rod 24 carries at its centre a 2" Sprocket, which is connected by Chain to Sprocket 23, a $\frac{3}{4}$ " Pinion 25 at one end, and a $\frac{3}{4}$ " Sprocket 37 (Fig. 2) at the other end.

The two cams that operate the heald frame tappets each consists of a Face Plate 56 (Fig. 5), fitted with a Threaded Boss and a $\frac{1}{2}$ " Bolt carrying six Washers. These Face Plates are mounted as shown with the Threaded Bosses diametrically opposite to each other on a Rod supported in the Corner Gussets 8 and 8a, and the Rod carries also a $1\frac{1}{2}$ " Contrate that is driven by the Pinion 25.

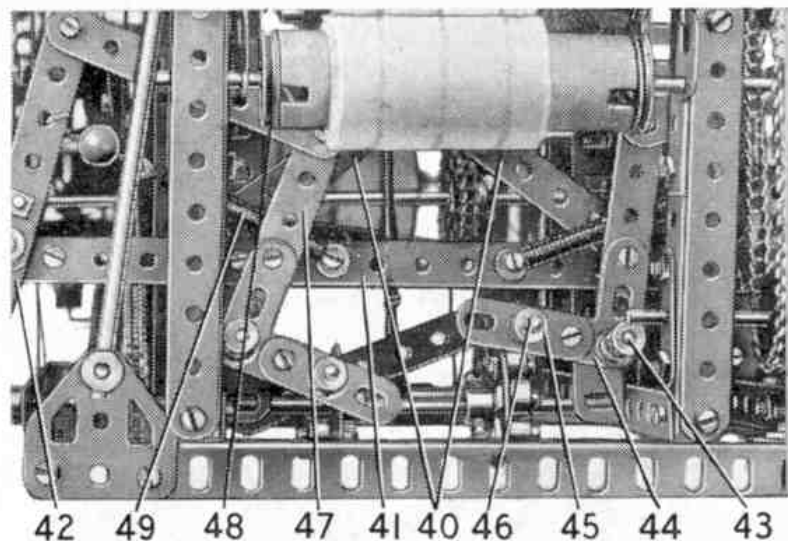

Fig. 3. A close-up view of the cam mechanism that operates the picking sticks.

$3\frac{1}{2}$ " Strip bolted to the side of the Girder 12 (Fig. 1). The sand roller 14, which is a Wood Roller with rough sand paper glued around, is held between 1" Pulleys on a Rod mounted in the girders 11.

The take-up Roller 15 is mounted on a Rod between 1" Pulleys, and the Rod slides between girders 11 and the Strips 13. This Roller is held against the sand roller 14 by the tension of two Driving Bands. These are attached to Fishplates slipped over the ends of the lower Roller Rod, and the Bands are anchored at their upper ends to the Pivot Bolt and $\frac{1}{2}$ " Bolt fixing the Girder 12 in position. The breast beam is braced by two $5\frac{1}{2}$ " Strips 16 placed as shown in Fig. 2.

The Drive

An E20R Electric Motor is bolted to one of the angle girders 10 (Fig. 5) and is supported also by a $2\frac{1}{2}$ " Strip 62 (Fig. 2) bolted to the base, and a $3\frac{1}{2}$ " Strip attached to a vertical $7\frac{1}{2}$ " Strip 63. A $2\frac{1}{2}$ " x $\frac{1}{2}$ " Double Angle Strip is bolted to the inner sideplate of the Motor and to one of the Girders 2. A $\frac{3}{4}$ " Bolt is used to fasten $2\frac{1}{2}$ " Strip 62 and the $3\frac{1}{2}$ " Strip to the Motor, and this Bolt acts also as a stop to prevent the Motor starting lever from going into reverse (Fig. 2). A $\frac{1}{2}$ " Pinion

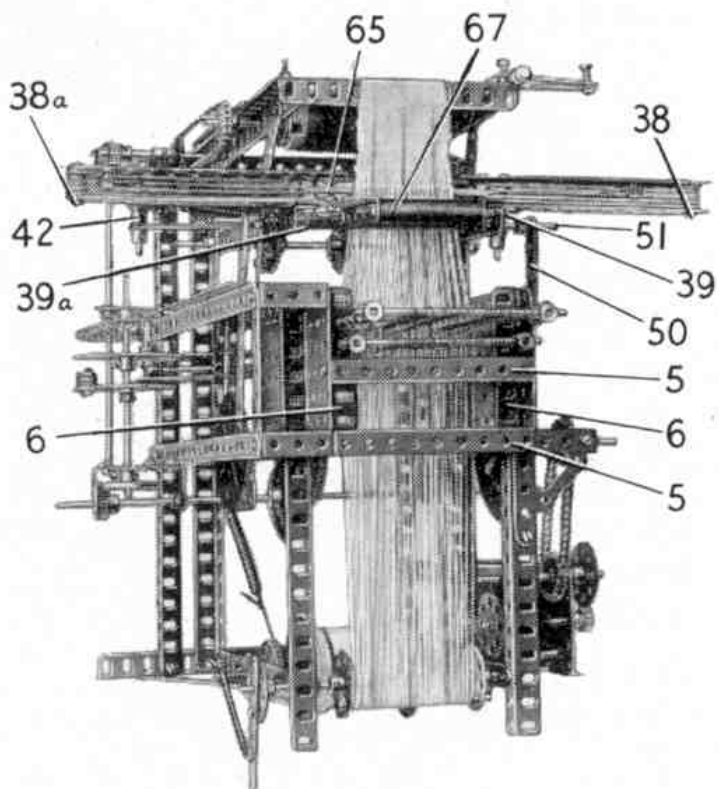

Fig. 4. The arrangement of the shuttle race can be seen in this overhead view.

This Rod carries also a $\frac{3}{4}$ " Sprocket 26 (Fig. 1), which drives a $1\frac{1}{2}$ " Sprocket 27 on Rod 28. Rod 28 is mounted in the Corner Brackets previously mentioned as bolted to the Angle Girders 7, and in another Corner Bracket fixed to the end of the base. This forms the drive to the sand roller, through a Worm 29 that engages a $\frac{1}{2}$ " Pinion 30. The Rod on which Pinion 30 is fixed is mounted in a $1\frac{1}{2}$ " Corner Bracket, and in a $1\frac{1}{2}$ " Strip bolted to one of the girders 11. A 1" Sprocket on this Rod is connected by Chain to a 1" Sprocket on the Rod of the sand roller 14.

The Motor is started and stopped from a control handle 31, which is a Rod fixed in a Threaded Coupling 32. An $11\frac{1}{2}$ " Screwed Rod is locked by a nut in the Coupling, and at a point about one inch from the other end of the Screwed Rod a Threaded Crank is fixed to it with two nuts. The end of the Screwed Rod is supported in a $1" \times 1"$ Angle Bracket held by Bolt 33 (Fig. 2) to the base. A $\frac{1}{2}$ " Bolt in the Motor starting lever engages with a $1" \times \frac{1}{2}"$ Angle Bracket bolted to the arm of the Threaded Crank.

The Picking Cams

The shuttle is "thrown" to and fro along the shuttle race or guide of the slay 64 (Fig. 1), by the action of picking sticks 42, which in turn are actuated by cams. Each of these two cams consists of four Collars bolted in four adjacent holes of a Bush Wheel 34 (Fig. 2), secured on a Rod 36. The entire slay assembly rocks to and fro on this Rod 36. A $\frac{3}{4}$ " Sprocket 37 drives a $1\frac{1}{2}$ " Sprocket 35 and rotates the cams in an anti-clockwise direction. It is important to note that these cams also are set at 180° to each other, that is with the Collars in each cam diametrically opposite.

The Slay and Shuttle Race

The shuttle race is made in two sections. Each of these is built-up by placing on a $\frac{3}{4}$ " Bolt 38 (Fig. 4) the following parts, in the order given starting from the head of the Bolt: a $5\frac{1}{2}"$ Flat Girder, a $9\frac{1}{2}"$ Strip, a Washer, a $5\frac{1}{2}"$ Strip, two Washers, a $5\frac{1}{2}"$ Strip, two Washers, a $5\frac{1}{2}"$ Strip, two Washers, a $5\frac{1}{2}"$ Strip, a $9\frac{1}{2}"$ Strip, a Washer and a second $5\frac{1}{2}"$ Flat Girder. The two

sections thus assembled are then placed together so that the $9\frac{1}{2}"$ Strips of one section overlap the same Strips of the other section by nine holes. The two sections are then connected together by the $1\frac{1}{8}"$ Bolts 39 and 39a (Fig. 4). The $5\frac{1}{2}"$ Strips of the sections are spaced apart on these Bolts by Washers, and in addition to the $5\frac{1}{2}"$ Strips the Bolts support three $4\frac{1}{2}"$ Strips 65 placed face to face at the exact centre of the shuttle race. Two Fishplates 66 (Fig. 1) are fixed to the front

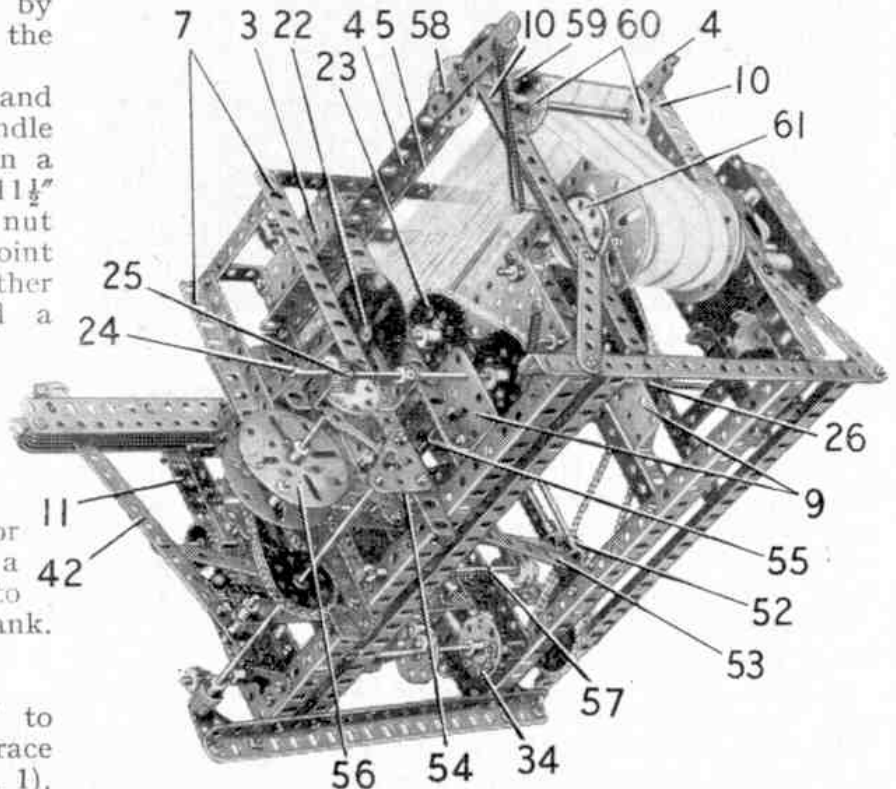

Fig. 5. The cams controlling the movements of the heald frames can be seen in this view of the loom.

edge of the shuttle race at the inner ends of the Flat Girders.

The reed 67 (Fig. 1) is built from $2\frac{1}{2}"$ Strips, which are spaced with Washers on two 3" Screwed Rods and edged at each side with a $2\frac{1}{2}"$ Angle Girder as shown. This unit is then bolted to the centre of the shuttle race. The shuttle race is attached by Bolts 39 and 39a (Fig. 4), to two $7\frac{1}{2}"$ Angle Girders, which are pivoted at their lower ends on the Rod 36 already mentioned. The Girders are braced by two crossed $5\frac{1}{2}"$ Strips 40 (Fig. 3). Two $9\frac{1}{2}"$ Strips 41 placed face to face are bolted centrally across the $7\frac{1}{2}"$ Angle Girders, and a Crank is bolted to each end of the Strips.

Each picking-stick 42 (Fig. 3), is a $7\frac{1}{2}"$ Strip, and it has a Fishplate fixed to its upper end as shown and a Double Arm Crank to its lower end. The Double Arm Crank of each

(Continued on page 614)

Continental carillons are often large, very heavy and complicated to set. The world's largest is at Bruges; it has more than 30,000 holes, and the task of re-arranging the pins to change the tunes takes a few days to complete.

In the modern carillon the tune-player is operated by electro-pneumatic action, and such apparatus is also used to bring out the full tones of the heaviest bells in a large carillon when this is played from a keyboard. Nowadays carillons are equipped with both the hand clavier, for recitals, and the automatic player, which is started by a clock and plays single note tunes, repeated two or three times as required, at pre-determined intervals of the day. An up-to-date chime barrel, pegged for a single tune, can be changed for another barrel in 30 seconds, or re-set for a new tune in about half an hour by anyone with ordinary musical ability.

The beginning of a carillon is the casting of the bells. In the first place a mould for shaping the inside of the bell is made with bricks and loam. The outer shape is formed with loam or clay inside an iron hood. When both moulds are set, the hood is clamped down over the inner mould, and then the molten metal is poured into the runner at the top from a huge ladle. After the metal has solidified and cooled, the bell is taken from the mould, which is then broken up, as it can be used once only.

After casting there comes the very important tuning process. In olden days craftsmen tuned their bells in very crude fashion, chipping away lumps of metal with a chiselling implement. Nowadays this is done with much greater care because

it is known that a bell does not ring with a single note, but has several overtones, which must be tuned in complete harmony one with the other. So the inverted bell is clamped on a revolving lathe, and particles of metal are pared away with a fine cutter from various parts of the surface until,



Pouring the molten metal into the finished mould to make a bell at the works of Mears and Stainbank.

after making repeated tests with the aid of a tuning-fork, the tuner is quite satisfied that the bell rings true.

One reason for the supremacy of British bells throughout the world today is their fine tuning. The old Continental bell-founders knew the secret of harmonic tuning, but this was lost for generations until rediscovered by a Sussex clergyman in the nineteenth century. It was immediately taken up by the English bell founders, who have since brought it to great perfection.

Among the Model-Builders—(Continued from page 631)

connected by $2\frac{1}{2}'' \times \frac{1}{2}''$ Double Angle Strips. A Wheel Disc is fixed to each Hub Disc and the assembly is held on the Rod 1 by Collars. One of the Wheel Discs is attached by eight $\frac{3}{8}''$ Bolts, one of which is indicated at 2.

The only parts of the mechanism fixed to the Rod 1 are the Gear 3, which takes the drive from the engine, and a Face Plate 4. The Face Plate is fitted with two Threaded Pins 5, and a 3" Pulley 6 is arranged so that it slides over them. A Compression Spring is placed between the Pulley 6 and the winding drum. Two Threaded Pins are attached to the boss of Pulley 6, but each is spaced from the boss by Washers, so that it does not grip the Rod 1.

The drive to the drum is engaged by sliding the Pulley 6 so that the Threaded Pins in its boss engage the $\frac{3}{8}''$ Bolts 2.

A New Meccano Loom—(Continued from page 636)

picking stick is held by a Collar on a $1\frac{1}{2}''$ Rod fixed in the Crank at the end of the Strips 41.

The picking sticks are operated by Bell Cranks 44, which are free to turn on 1" Rods fixed in Rod Sockets bolted to the lower ends of the $7\frac{1}{2}''$ Angle Girders that support the shuttle race. The Bell Cranks are held on the 1" Rods by Collars, and one arm of each is extended by a 3" Strip 47, and a Double Arm Crank 45 is bolted to the other arm. A $1\frac{1}{2}''$ Rod 46 is fixed in the Double Arm Crank and engages the cam 34. The upper ends of Strips 47 are connected to the picking sticks 42 by $3\frac{1}{4}''$ Strips 48, pivoted on lock-nutted bolts. The force with which the picking sticks operate is controlled by Springs 49. Each is bolted to Strips 41 and connected by a small Loaded Hook to the picking stick. The slay is linked by Strips locknutted to Gears on Rod 22 and fitted with Cranks 50 fixed on Rod 51.

A New Meccano Loom

The Beaming Frame and Other Details

By 'Spanner'

ASSUMING that the Loom has been built up to the stage described in last month's *M.M.*, the next operation is the construction of the Heald Frames. These are the frames that hold the Healds through which the warp threads are passed from the beam. They are actuated by the cams 56 and rise and fall to provide the "shed" through which the shuttle carrying the weft thread passes.

On a 4" Rod (bottom) and a 4½" Rod (top) 30 Healds should be placed, with a Coupling on each end of each Rod. The Couplings are joined together lengthwise by 5" Rods, and these must be passed through the top 3½" Angle Girders 6 before the Rods are fixed in the Couplings. The lower Couplings carry 3½" Rods to extend the 5" Rods lengthwise, and an End Bearing 52 (Fig. 3, December *M.M.*) is secured to the bottom of one of the Rods. A 7½" Strip 53 is pivoted between the lugs of the End Bearing, and this Strip is *lock-nutted* to a Fishplate 54 pivoted on Rod 55. The Fishplate is *lock-nutted* in the 10th hole of Strip 53, counting from the End Bearing. Spring Clips are used to space the Fishplates and hold the Strips 53 in line with cams 56.

After being raised by the action of the cams, the Heald Frames are returned to their lowest positions by the tension of 2½" and 6" Driving Bands looped together and anchored on a Rod 57 (Fig. 3), and the bottom of the Heald Frames. The Heald Frames should move very freely on depressing Strips 53.

The Warp Tension Mechanism

A simple mechanism is provided to keep the warp threads at a suitable tension. This is shown clearly in Figs. 3 and 4. Two Bush Wheels are fixed to Rod 58, with a 3" Rod 59 mounted in holes in the Bush Wheels. A Bush Wheel extended with a 3" Strip is fixed to the end of Rod 58. A 6" Driving Band looped between the 3" Strip, and a 1½" Bolt fixed to the

frame imparts the required tension to the warp threads while the Heald Frames are moving up and down. A Cord, slightly tensioned with a Spring and passed over a 1½" Pulley 61, maintains tension on the warp beam.

The Shuttle

Construction of the shuttle, which is shown in Fig. 2 on the opposite page, is quite simple. It consists of two 3½" Strips, two End Bearings and a 1½" Rod. The ends of the Strips are bent slightly to fit the lugs of the End Bearings. A ¾" Bolt, which should for preference be

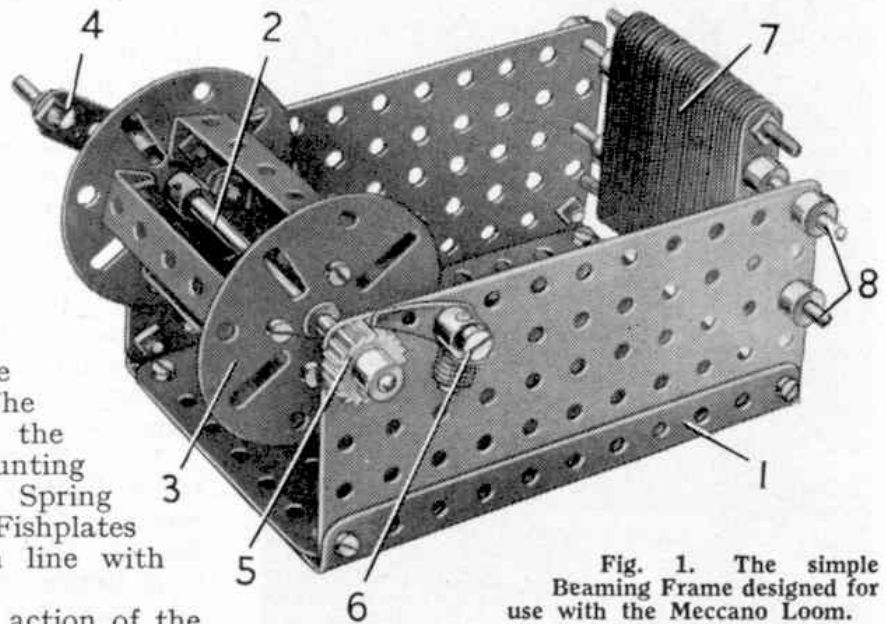

Fig. 1. The simple Beaming Frame designed for use with the Meccano Loom.

filed slightly shorter, is passed through the end hole of one of the Strips and then through the lugs of an End Bearing. A Washer is placed on the Bolt between the lugs of the Bearing, and the Bolt is then passed through the end hole of the other 3½" Strip. This process is repeated at the other ends of the Strips.

A 1½" Rod that forms the spindle on which the weft thread is wound, is held loosely in the bosses of the End Bearings, and is retained in place by stops made by screwing the grub screws right down. *The grub screws must not grip the Rod.* The sides of the shuttle must be parallel and the completed shuttle must be an easy sliding fit in the shuttle race. When

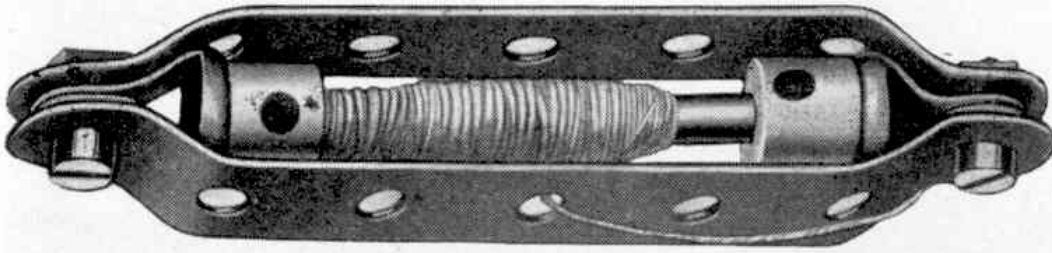

Fig. 2. The built-up Loom Shuttle.

Drawing the warp

Put the prepared beam in the

loom. Take the first thread, pull it through the *first* heald on the *front* frame, then the second thread and pull it through the *first* heald on the *back* frame. These two threads are drawn through the *first* division or dent in the reed. Continue in this way using each dent until all the threads are drawn through. Lightly brush and pass them around the upper roller and secure them to the take-up roller by means of the Rod placed in its groove.

it is in position in the race the picking sticks must strike the shuttle nose centrally. Carefully wind some "weft" thread on the shuttle spindle, keeping it in the centre portion of the Rod. Do not try to put too much on at one filling, and make sure it will run off perfectly freely, otherwise the shuttle may "stick" between the warp threads. The thread is then brought out from the shuttle as shown.

loom. Take the first thread, pull it through the *first* heald on the *front* frame, then the second thread and pull it through the *first* heald on the *back* frame. These two threads are drawn through the *first* division or dent in the reed. Continue in this way using each dent until all the threads are drawn through. Lightly brush and pass them around the upper roller and secure them to the take-up roller by means of the Rod placed in its groove.

Beaming Frame

Fig. 1 shows a simple Beaming Frame suitable for preparing the beam of warp threads ready for insertion in the Loom. The base of the frame is a $5\frac{1}{2}'' \times 3\frac{1}{2}''$ Flat Plate, fitted at each side with a $5\frac{1}{2}''$ Angle Girder 1 that supports a $5\frac{1}{2}'' \times 2\frac{1}{2}''$ Flat Plate. A Rod 2 carries the beam 3 on which the threads are wound.

Timing the Loom

The mechanism must be set so that when the slay is at back centre, one heald frame is in its highest position and will stay up until the shuttle has passed through the warp threads. The picking stick motion should then come into action just before the slay reaches back-dead centre, and should shoot the shuttle across to reach the other end just as the slay leaves back dead-centre. A little time spent in careful adjustment will soon give the desired position for smooth running.

A handle 4 is fitted to one end of the Rod 2, and the other end carries a Ratchet Wheel 5. A Pawl 6 on a Pivot Bolt engages the teeth of the Ratchet Wheel. The Pawl is weighted by Washers on a $\frac{3}{8}''$ Bolt screwed into its boss.

The reed or frame 7 consists of 31 $2\frac{1}{2}''$ Strips spaced apart by Washers on two Screwed Rods, and is supported in the $5\frac{1}{2}'' \times 2\frac{1}{2}''$ Flat Plates by Collars on two Rods 8.

Now knock two nails into a wall, a few yards apart, and then wind around them 30 turns of thread. These are now taken off the nails carefully, and cut at one end. You will then have 60 separate lengths of thread. The threads are now drawn through the reed, two threads between each pair of Strips, and with one knot are secured to the centre of the beam axle. Holding the threads tightly in the left hand, wind them on to the beam; the reed will space the threads evenly between the Face Plates. A little practice will soon produce a neat beam.

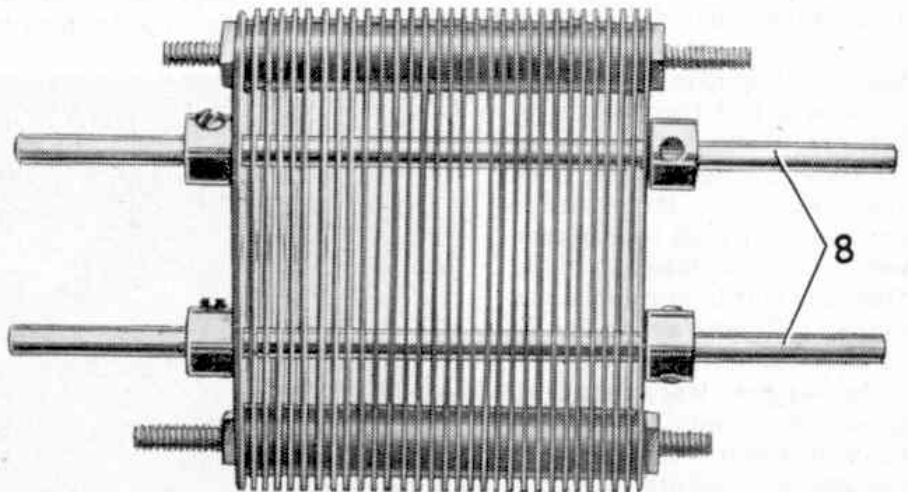

Fig. 3. The reed removed from the Beaming Frame to show its construction more clearly

Parts required to build the Meccano Loom: 6 of No. 1a; 5 of No. 1b; 14 of No. 2; 5 of No. 2a; 9 of No. 3; 3 of No. 4; 33 of No. 5; 1 of No. 6a; 4 of No. 8; 6 of No. 8a; 4 of No. 8b; 9 of No. 9; 2 of No. 9a; 6 of No. 9b; 2 of No. 9d; 10 of No. 10; 1 of No. 12; 3 of No. 12a; 1 of No. 12b; 1 of No. 13; 3 of No. 13a; 4 of No. 14; 6 of No. 15; 5 of No. 15a; 2 of No. 15b; 6 of No. 16; (Continued on page 50)

A New Meccano Loom—

(Cont. from p. 39)

1 of No. 16a; 4 of No. 16b; 5 of No. 18a; 2 of No. 18b; 2 of No. 21; 4 of No. 22; 1 of No. 23a; 5 of No. 24; 1 of No. 25; 4 of No. 26; 2 of No. 27a; 1 of No. 27b; 1 of No. 27c; 1 of No. 28; 1 of No. 32; 12 of No. 35; 172 of No. 37a; 120 of No. 37b; 154 of No. 38; 3 of No. 43; 2 of No. 48; 5 of No. 48a; 2 of No. 48c; 2 of No. 52a; 3 of No. 57c; 24 of No. 59; 4 of No. 62; 1 of No. 62a; 4 of No. 62b; 8 of No. 63; 1 of No. 63c; 2 of No. 64; 1 of No. 78; 2 of No. 80c; 2 of No. 94; 2 of No. 95; 2 of No. 95a; 4 of No. 96; 2 of No. 96a; 60 of No. 101; 4 of No. 103; 2 of No. 106; 3 of No. 108; 4 of No. 109; 3 of No. 111; 6 of No. 111a; 24 of No. 111c; 3 of No. 111d; 2 of No. 120b; 1 of No. 126a; 2 of No. 128; 4 of No. 133; 1 of No. 136a; 1 of No. 144; 2 of No. 147b; 2 of No. 161; 4 of No. 166; 2 of No. 179; 2 of No. 186; 5 of No. 186a; 1 of No. 213; 1 E20R Electric Motor.

The parts used in the Beaming Frame should be clear from the illustrations.



The third annual mystery train trip organised by Hobby Shop Ltd., Meccano dealers in Adelaide, South Australia, involved the running of the Hobby Shop Special shown in this picture. This was the first occasion on which a diesel-electric locomotive was used for the train.

FLASHLIGHT PHOTOGRAPHY COMPETITION

Flashlight photography is becoming increasingly popular, and readers who are interested in this fascinating branch of photography will welcome the news that Johnsons of Hendon Ltd., the well-known makers and distributors of photographic chemicals and apparatus, have announced a new competition solely for flashlight photography. Cash prizes to a total value of £100 will be awarded as follows: Three first prizes of £10 each; Five second prizes of £5 each; Eight third prizes of £3 each; Twenty-four prizes of one guinea each, and Consolation prizes for other good efforts.

The photographs can be taken by any form of flash—open, synchronised, electronic or even flashpowder—and they can be indoor or outdoor, daylight or night time pictures. The only conditions are that the photographer must have performed the processing of either the negative or the print himself. The prints must be postcard-size or larger, and preferably should be mounted. There is no entry fee, but a label from a Johnson product should be sent with each entry, which is limited to six prints from any one competitor.

A leaflet giving full details of the competition can be obtained from any photographic dealer or chemist, or direct from Johnsons of Hendon Ltd., Hendon Way, Hendon, London N.W.4.

This Month's Special Articles

	page
The Helix	2
My First Monte Carlo Rally by Stirling Moss	4
Preparing for the Monte Carlo Rally by Ian Appleyard	7
The Monte in a Ford Anglia	10
by Jack Reece	
The Story of the Monte	13
by J. Dewar McLintock	
The U.S.A.F.'s Trapeze Artists	16
by John W. R. Taylor	
Swing Trains of the Northlands	20
by Frank Illingworth	
The Aero-Isoclinic Wing	23
by John W. R. Taylor	



The rather jovial snow clock seen in this picture, from a photograph by C. D. Mason, London E.12, is an example of the use of snow made in certain parts of Switzerland for publicity purposes.