

New Meccano Models

Swing-Boat Tank Locomotive

THE simple model of a swing-boat seen in Figs. 1 and 2 can be built from a No. 3 Outfit. The model is shown operated by a Crank Handle, but if desired it can be driven by a Magic Motor.

The base consists of two $12\frac{1}{2}$ " Strips. The swing-boat is supported at each side by two $5\frac{1}{2}$ " Strips, which are joined, at their upper ends by a Semi-Circular Plate, and bolted at their lower ends to Trunnions and Flat Trunnions fixed to the base. The Trunnions are connected by a $2\frac{1}{2}$ " Strip, and the Flat Trunnions by a $2\frac{1}{2}$ " Strip and two Angle Brackets.

The bottom of the swing-boat is a $5\frac{1}{2} \times 2\frac{1}{2}$ " Flanged Plate, and the sides are $5\frac{1}{2} \times 2\frac{1}{2}$ " Flexible Plates. Its ends are $2\frac{1}{2} \times 2\frac{1}{2}$ " Flexible Plates, and they are connected to the sides by $2\frac{1}{2} \times \frac{1}{2}$ " Double Angle Strips 2. The framework of the roof consists of $5\frac{1}{2}$ " Strips 3 attached by Angle Brackets to $2\frac{1}{2}$ " small radius Curved Strips. It is bolted to $2\frac{1}{2}$ " Strips fixed to the sides. The roof is a $4\frac{1}{2} \times 2\frac{1}{2}$ " Flexible Plate extended by a $1\frac{1}{16}$ " radius Curved Plate, and it is attached to the framework by Angle Brackets.

The swing-boat is pivoted on a $3\frac{1}{2}$ " Rod

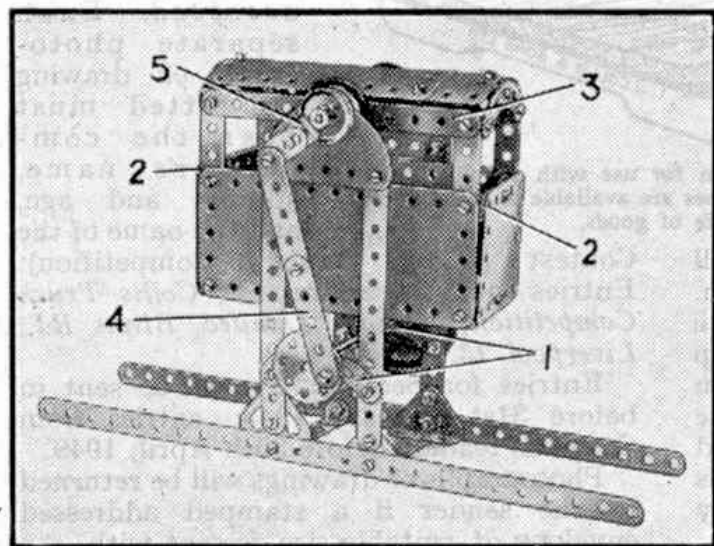

Fig. 1. A simple model Swing-boat that can be built from Outfit No. 3.

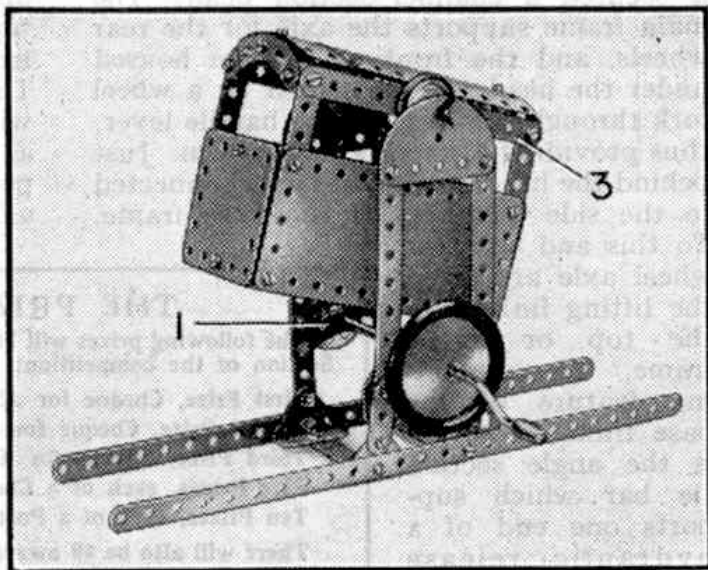

Fig. 2. Another view of the Swing-boat.

mounted in the Semi-Circular Plates. This Rod carries two 1" Pulleys, which are fitted with Rubber Rings and arranged to press against the Strips 3.

The outer end of the $3\frac{1}{2}$ " Rod carries a 1" Pulley, to the boss of which an Angle Bracket 5 is bolted. The Angle Bracket is extended by a Fishplate, to which a compound strip 4 is lock-nutted. The strip 4 is made by joining together two $2\frac{1}{2}$ " Strips, and its lower end is lock-nutted to a Bush Wheel fixed to a Crank Handle journalled in $2\frac{1}{2}$ " small radius Curved Strips 1 bolted to the vertical supports.

Our other new model is the fine locomotive shown in Figs. 4 and 5. This is based on a type of 4-6-2 tank engine used for local passenger and goods traffic.

The main frames of the locomotive are formed by a compound angle girder 1 on each side of the model. These consist of $12\frac{1}{2}$ " and $3\frac{1}{2}$ " Angle Girders and they are connected at each end by a $3\frac{1}{2}$ " Angle Girder. Two $12\frac{1}{2}$ " Angle Girders 2 are bolted between the girders 1, at the front to the $3\frac{1}{2}$ " Angle Girder, and in the centre to $3\frac{1}{2}$ " Strips bolted across the girders 1.

The sides of the water tanks and the coal bunker consist of $5\frac{1}{2} \times 2\frac{1}{2}$ " and $3\frac{1}{2} \times 2\frac{1}{2}$ " Flexible Plates respectively. These are bolted to $9\frac{1}{2}$ " Angle Girders 5, and the $5\frac{1}{2} \times 2\frac{1}{2}$ " Flexible Plates are strengthened by $5\frac{1}{2}$ " and $2\frac{1}{2}$ " Angle Girders, while the $3\frac{1}{2} \times 2\frac{1}{2}$ " Flexible Plates are braced by $3\frac{1}{2}$ " and $2\frac{1}{2}$ " Angle Girders. The front and rear of the coal bunker are each represented by a $3\frac{1}{2} \times 2\frac{1}{2}$ " Flexible Plate.

The forward section of the boiler

is made by curving four $5\frac{1}{2}'' \times 2\frac{1}{2}''$ Flexible Plates around two $2\frac{1}{2}'' \times \frac{1}{2}''$ Double Angle Strips to form a cylinder. The rear section consists of two $4\frac{1}{2}'' \times 2\frac{1}{2}''$ Flexible Plates bolted together and to the cylinder. The edges of the $4\frac{1}{2}'' \times 2\frac{1}{2}''$ Flexible Plates

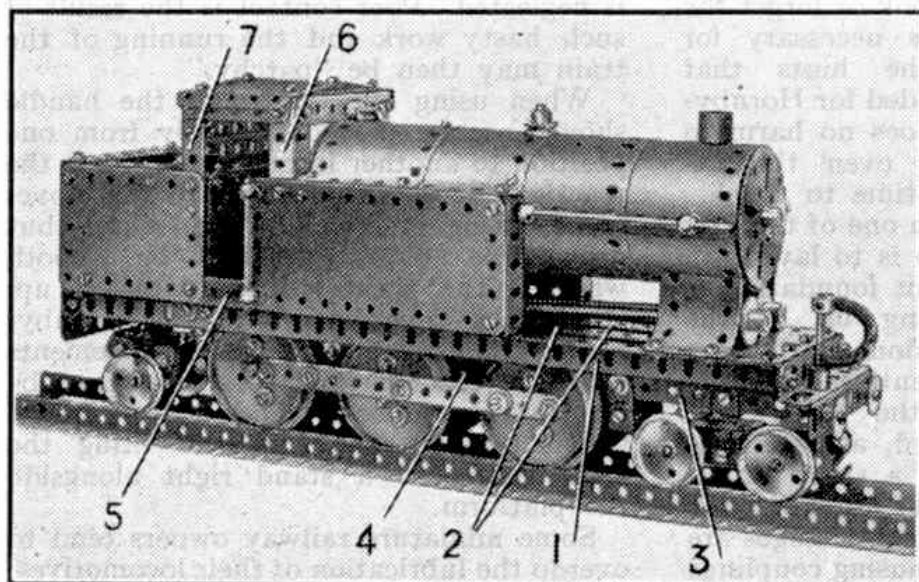

Fig. 3. This fine 4-6-2 type tank locomotive makes an interesting subject for a working model.

are attached to the tops of the water tanks. The front of the boiler is supported by a $5\frac{1}{2}'' \times 1\frac{1}{2}''$ Flexible Plate bent as shown and fixed to the girders 1.

The cab roof is supported by four 2" Angle Girders, two of which are seen at 6 and 7. The Girders 6 and 7 are connected by a $2\frac{1}{2}''$ Angle Girder, and joined to the Girders on the opposite side by $3\frac{1}{2}''$ Strips. The roof is a $4\frac{1}{2}'' \times 2\frac{1}{2}''$ Flexible Plate curved slightly and bolted in position. The back of the cab is filled in by $3\frac{1}{2}''$ Strips, and the rear of the boiler by a $3\frac{1}{2}'' \times 2\frac{1}{2}''$ Flexible Plate and a Semi-Circular Plate. The floor is a $5\frac{1}{2}'' \times 2\frac{1}{2}''$ Flexible Plate.

A $12\frac{1}{2}''$ Flat Girder 3 is bolted to each of the Angle Girders 2, and extended downward by a $9\frac{1}{2}''$ Flat Girder 4. The Flat Girders 4 provide bearings for the driving wheels, which are made by bolting Wheel Flanges to Face Plates. The Flat Girders 4 are connected by three $1\frac{1}{2}'' \times \frac{1}{2}''$ Double Angle Strips 8.

The driving wheels are fixed on $2\frac{1}{2}''$

Rods and spaced from the Flat Girders 4 by Washers. The wheels on each side are linked by a connecting rod formed from two $5\frac{1}{2}''$ Strips overlapped nine holes. The connecting rods are pivotally attached to the wheels by $\frac{3}{4}''$ Bolts and spaced by Collars and Washers.

The front bogie is made by bolting a $2\frac{1}{2}''$ Strip to each of the lugs of a $1\frac{1}{2}'' \times \frac{1}{2}''$ Double Angle Strip. The $2\frac{1}{2}''$ Strips are spaced inward by four Washers. The wheels are $1\frac{1}{8}''$ Flanged Wheels fixed on 2" Rods mounted in the $2\frac{1}{2}''$ Strips. The bogie is attached to the leading Double Angle Strip 8 by a $2\frac{1}{2}''$ Strip held by a lock-nutted bolt.

The rear bogie is made by bolting $1\frac{1}{2}''$ Flat Girders to the lugs of two $1\frac{1}{2}'' \times \frac{1}{2}''$ Double Angle Strips. The Flat Girders are spaced inward by four Washers, and the wheels are fixed on a 2" Rod mounted in the Flat Girders. The bogie is bolted to a $2\frac{1}{2}''$ Strip lock-nutted to the rear $1\frac{1}{2}'' \times \frac{1}{2}''$ Double Angle Strip 8.

The front buffer beam is built up from two $3\frac{1}{2}''$ Angle Girders, and the buffers consist of $\frac{3}{4}''$ Washers and Washers placed over $\frac{3}{8}''$ Bolts. The vacuum pipe is a Spring passed over a $1\frac{1}{2}''$ Rod held in a Rod Socket. The rear buffer beam is a $3\frac{1}{2}''$ Flat Girder.

The smoke-box door is a Face Plate fitted on a Threaded Pin attached to the centre of the $2\frac{1}{2}'' \times \frac{1}{2}''$ Double Angle Strip at the front of the boiler. The chimney is a Chimney Adaptor and a $\frac{1}{2}''$ Pulley is used to represent the steam dome.

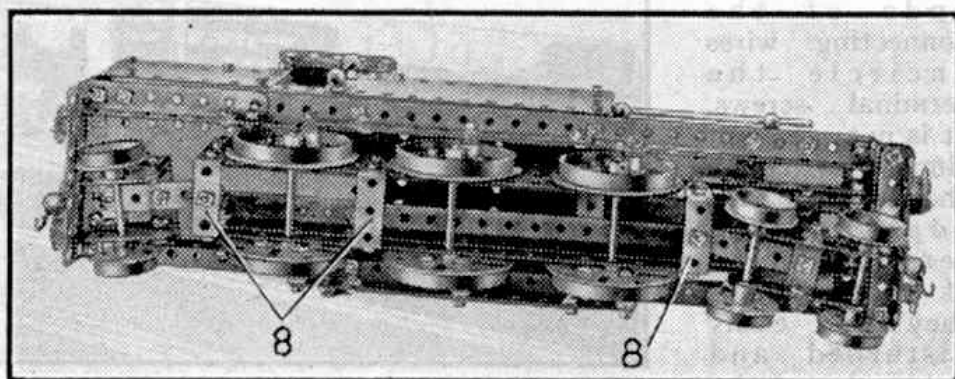

Fig. 4. The model locomotive seen from underneath.